

2017

# Observing and modeling drivers' behavior in work zones using SHRP 2 naturalistic driving study data

Hossein Naraghi  
Iowa State University

Follow this and additional works at: <https://lib.dr.iastate.edu/etd>

 Part of the [Civil Engineering Commons](#), and the [Transportation Commons](#)

## Recommended Citation

Naraghi, Hossein, "Observing and modeling drivers' behavior in work zones using SHRP 2 naturalistic driving study data" (2017).  
*Graduate Theses and Dissertations*. 17273.  
<https://lib.dr.iastate.edu/etd/17273>

This Dissertation is brought to you for free and open access by the Iowa State University Capstones, Theses and Dissertations at Iowa State University Digital Repository. It has been accepted for inclusion in Graduate Theses and Dissertations by an authorized administrator of Iowa State University Digital Repository. For more information, please contact [digirep@iastate.edu](mailto:digirep@iastate.edu).

# **Observing and modeling drivers' behavior in work zones using SHRP 2 naturalistic driving study data**

by

**Hossein Naraghi**

A dissertation submitted to the graduate faculty  
in partial fulfillment of the requirements for the degree of

**DOCTOR OF PHILOSOPHY**

Major: Civil Engineering (Transportation Engineering)

Program of Study Committee:

Omar Smadi, Major Professor

Jing Dong

Alicia Carriquiry

Keith Knapp

Jennifer Shane

The student author, whose presentation of the scholarship herein was approved by the program of study committee, is solely responsible for the content of this dissertation. The Graduate College will ensure this dissertation is globally accessible and will not permit alterations after a degree is conferred.

Iowa State University

Ames, Iowa

2017

Copyright © Hossein Naraghi, 2017. All rights reserved.

## DEDICATION

I take pleasure in dedicating this research to the teacher of mystical love and consciousness, Mohammad Ali Taheri, who dedicated his life to teach the philosophy of creation, who we are, where we came from, why we are here, and where we are going to, through connection to the source.

*The interuniversalism unity is the same as Divine Unity and the day human comes to the perception of this unity and sees himself in unity with the universe and realizes that he goes toward the same direction as the universe, does it reach the boundary of becoming like God and seeing as God sees? That's when everywhere we turn, can perceive the light of God's manifestation and see nothing except God.*

Mohammad Ali Taheri



در امتداد شب نشینیم و طلوع کنیم  
به یک تلنگر ساده بیا تا رجوع کنیم  
چرا غرور تفاخر بیا تا رکوع کنیم

به نام بی نام او بیا تا شروع کنیم  
مهم نیست چگونه، چطور و چند  
ببین که خاک چگونه به سجده افتاده است

تقدیم به استاد عشق و معرفت، معلم دکترای بشریت، شهید شاهد،

استاد محمد علی طاهری

## TABLE OF CONTENTS

<b>LIST OF FIGURES .....</b>	<b>vii</b>
<b>LIST OF TABLES .....</b>	<b>xii</b>
<b>NOMENCLATURE.....</b>	<b>xiv</b>
<b>ACKNOWLEDGMENTS .....</b>	<b>xvi</b>
<b>ABSTRACT.....</b>	<b>xviii</b>
<b>CHAPTER 1. GENERAL INTRODUCTION .....</b>	<b>1</b>
1.1 Contributing Factors to Work Zone Safety Problem .....	1
1.2 The Opportunity of Utilizing Naturalistic Driving Study.....	2
1.2.1 Background on SHRP 2 Naturalistic Driving Study .....	3
1.2.2 Background on SHRP 2 Roadway Information Database .....	4
1.3 Previous Research.....	4
1.3.1 Work Zone Crash Characteristics .....	5
1.3.2 Work Zone Crash Types .....	7
1.3.3 Work Zone Crash Locations .....	9
1.3.4 Work Zone Crash Contributing Factors .....	10
1.3.5 Temporal and Environmental characteristics .....	11
1.3.6 Driver Characteristics .....	12
1.3.7 Effectiveness of Work Zone Safety Measures.....	14
1.3.8 Summary of Major Findings.....	22
1.4 Problem Statement.....	24
1.5 Purpose of the Research.....	25
1.6 Research Questions.....	26
1.6.1 Research Question 1: What are the contributing factors to safety critical events in work zones compared to baseline (normal driving)? .....	26
1.6.2 Research Question 2: Where drivers start to react to the presence of work zones and how they interact with various safety measures in work zones? .....	27

1.6.3 Research Question 3: How drivers negotiate work zones and how effective are the safety features in getting drivers' attention? .....	28
1.7 Dissertation Organization .....	28
1.8 References.....	29
<b>CHAPTER 2. ANALYSIS OF CRASHES AND NEAR-CRASHES IN WORK ZONES USING SHRP 2 NATURALISTIC DRIVING STUDY DATA .....</b>	<b>35</b>
2.1 Introduction.....	36
2.1.1 Background on SHRP 2 Naturalistic Driving Study .....	38
2.1.2 Background on SHRP 2 Roadway Information Database .....	38
2.2 Literature Review.....	39
2.2.1 Work Zone Crash Characteristics .....	39
2.2.2 Work Zone Crash Types .....	42
2.2.3 Work Zone Crash Locations.....	43
2.2.4 Work Zone Crash Contributing Factors .....	44
2.2.5 Temporal and Environmental characteristics .....	45
2.2.6 Driver Characteristics .....	46
2.2.7 Summary of Findings .....	48
2.3 Data Collection and Reduction .....	50
2.3.1 SHRP 2 Study Sample Proportion .....	51
2.4 Methodology .....	53
2.4.1 Descriptive Statistical Analysis Results .....	53
2.4.2 Logistic Regression Modeling .....	62
2.5 Summary and Conclusions .....	66
2.5.1 Limitations .....	68
2.6 References.....	69
<b>CHAPTER 3. MULTIPLE CHANGEPOINTS DETECTION OF SPEED TIME SERIES TRACES IN WORK ZONES USING SHRP 2 NATURALISTIC DRIVING STUDY DATA .....</b>	<b>73</b>
3.1 Introduction.....	74
3.1.1 Background on SHRP 2 Naturalistic Driving Study .....	76
3.1.2 Background on SHRP 2 Roadway Information Database .....	77

3.2 Literature Review.....	77
3.3 Data Descriptions.....	81
3.3.1 Data Collection and Data Reduction .....	82
3.3.2 Identification of Work Zones of Interest .....	84
3.4 Methodology.....	88
3.4.1 Background on Multiple Changepts Detection Algorithms .....	88
3.4.2 Pruned Exact Linear Time (PELT) Algorithm .....	90
3.4.3 Application of PELT for Driver Speed Behavior in Work Zones .....	91
3.5 Multiple Changepoint Analysis Results.....	93
3.5.1 Left Lane Closure with a DMS after Work Zone first Warning Sign .....	95
3.5.2 Left Lane Closure with a DMS after Lane Merge Sign.....	118
3.5.3 Left Lane Closure with a DSFS after Work Zone First Warning Sign .....	121
3.5.4 Left Lane Closure on Multi-lane Divided Rural Highway .....	125
3.5.5 Right Lane Closure with a DSFS after Work Zone First Warning Sign ....	128
3.5.6 Left Shoulder Closure.....	132
3.5.7 Right Shoulder Closure.....	135
3.5.8 Both Shoulders Closure .....	138
3.5.9 Lane Shift.....	141
3.6 Summary and Discussion.....	144
3.6.1 Speed Profile Dispersion .....	145
3.6.2 Countermeasures Effectiveness .....	151
3.6.3 Reaction by Gender .....	156
3.6.4 Reaction by Lane .....	157
3.7 Conclusions.....	157
3.7.1 Limitations .....	160
3.8 References.....	160
3.9 Appendix 3: Speed Profile Distributions .....	165

**CHAPTER 4. DRIVER BEHAVIOR STUDY BY FUNCTIONAL DATA  
ANALYSIS OF SPEED PROFILES IN WORK ZONES USING  
SHRP 2 NATURALISTIC DRIVING STUDY DATA ..... 175**

4.1 Introduction.....	176
4.1.1 Background.....	176

4.1.2 Background on SHRP 2 Naturalistic Driving Study .....	177
4.1.3 Background on SHRP 2 Roadway Information Database .....	178
4.1.4 Background on Functional Data Analysis (FDA) .....	179
4.2 Literature Review.....	180
4.3 Data Descriptions.....	184
4.3.1 Data Collection and Data Reduction .....	184
4.3.2 Identification of Work Zones of Interest .....	187
4.4 Methodology.....	189
4.4.1 Applying Functional Data Analysis to Discrete Raw Data .....	189
4.4.2 Developing Smooth Curves by Basis Expansion .....	191
4.4.3 Smoothing Process by B-splines .....	192
4.4.4 Functional Data Summary Statistics.....	196
4.4.5 Legibility Distance.....	201
4.5 Functional Data Analysis Results.....	203
4.5.1 Left Lane Closure with a DMS after Work Zone First Warning Sign .....	205
4.5.2 Left Lane Closure with a DMS after Lane Merge Sign.....	217
4.5.3 Left Lane Closure with a DSFS after Work Zone First Warning Sign .....	225
4.5.4 Right Lane Closure with a DSFS after Work Zone First Warning Sign ....	233
4.5.5 Lane Shift.....	242
4.6 Summary and Discussion.....	249
4.6.1 Mean Speed and Safety Feature Effectiveness .....	250
4.6.2 Risks Associated with Speed Variations .....	253
4.6.3 Vehicle mean deceleration profiles in work zones .....	255
4.6.4 Effectiveness of Safety Features' Layout .....	258
4.7 Conclusions.....	258
4.8 References.....	261
<b>CHAPTER 5. GENERAL CONCLUSIONS.....</b>	<b>265</b>
5.1 Conclusions and Implications .....	265
5.2 Limitations .....	272
5.3 Future Research .....	273
<b>APPENDIX A. IRB APPROVAL FORM .....</b>	<b>276</b>

## LIST OF FIGURES

Figure 1.1 Proportion of crash causation (Rumar et al., 1985).....	12
Figure 1.2 Work zone intervention layout (Allpress et al., 2010) .....	19
Figure 1.3 Cone arrangements used in the study (Allpress et al., 2010) .....	19
Figure 2.1 Proportion of crash causation (Rumar et al., 1985).....	47
Figure 2.2 Proportion of drivers by age group & gender for NDS and study sample .....	52
Figure 2.3 Proportion of drivers by age group and gender for safety critical and baseline events samples .....	52
Figure 2.4 Safety Critical Events Distribution.....	54
Figure 2.5 Event type by age group .....	55
Figure 2.6 Event type by driver gender .....	56
Figure 2.7 Driving maneuver prior to the event .....	56
Figure 2.8 Diver behavior and contributing factors by event type .....	57
Figure 2.9 Secondary task distribution by event type.....	58
Figure 2.10 Lane closure type and location by event type .....	58
Figure 2.11 Traffic condition in work Zones by event type .....	59
Figure 3.1 Applied safety measures in work zone one .....	92
Figure 3.2 Typical TTCD application for a stationary lane closure arrangement on a divided highway (FHWA 2009) .....	94
Figure 3.3 Work zone one with left lane closure and utilized safety features types and locations .....	96



Figure 3.4 Visual illustration of work zone 1 speed profiles distributions for all drivers .....	97
Figure 3.5 Changepoint detection model sensitivity analysis .....	99
Figure 3.6 Developing multiple changepoint model for overall drivers in work zone one .....	102
Figure 3.7 Plot of speed time series distributions for male drivers .....	103
Figure 3.8 Developing multiple changepoint model for male drivers in work zone one .....	104
Figure 3.9 Visual illustration of speed time series distribution for female drivers' traces ...	107
Figure 3.10 Developing multiple changepoint model for female drivers in work zone one .....	108
Figure 3.11 Visual illustration of speed time series distribution for closed lane drivers.....	110
Figure 3.12 Developing multiple changepoint model for closed lane drivers in work zone one.....	111
Figure 3.13 Visual representation of speed time series distribution for open lane drivers...	113
Figure 3.14 Developing multiple changepoint model for open lane drivers in work zone one .....	114
Figure 3.15 Developing multiple changepoint models for work zone two.....	119
Figure 3.16 Developing multiple changepoint models for work zone three.....	122
Figure 3.17 Developing multiple changepoint models for work zone four .....	126
Figure 3.18 Developing multiple changepoint models for work zone five .....	129
Figure 3.19 Developing multiple changepoint models for work zone six .....	133
Figure 3.20 Developing multiple changepoint models for work zone seven .....	136

Figure 3.21 Developing multiple changepoint models for work zone eight.....	139
Figure 3.22 Developing multiple changepoint models for work zone seven .....	142
Figure 3.23 Speed profile distributions for all 9 work zones in the study .....	145
Figure 3.24 Speed profile distributions by gender for all 9 work zones in the study .....	147
Figure 3.25 Speed profile distributions by driving lane for all 9 work zones in the study...	150
Figure 4.1 Single speed time series trace of discrete raw data converted into a functional curve at 3, 2, and 1 second interval from top to bottom panel, respectively .....	190
Figure 4.2 Scree plot for selecting the optimal number of basis functions.....	193
Figure 4.3 The length of 2.3 mile work zone is illustrated by 17 spline basis functions and 13 interior knots with order four polynomials .....	193
Figure 4.4 Process of developing and smoothing functional data .....	196
Figure 4.5 Plot of smoothed speed profiles in work zone with calculated mean for 62 traces .....	197
Figure 4.6 Plot of smoothed speed profiles in work zone 1 with calculated mean and confidence interval.....	198
Figure 4.7 A plot of a speed profile (top panel) along with its first derivative (bottom panel).....	199
Figure 4.8 Functional boxplot of speed profiles in work zone one .....	200
Figure 4.9 Typical TTCD application for a stationary lane closure arrangement on a divided highway (FHWA 2009) .....	204
Figure 4.10 Work zone one with left lane closure and utilized safety features types and locations .....	206

Figure 4.11 Speed time series profiles showing male and female drivers in work zone one .....	207
Figure 4.12 Speed time series traces showing open and closed lane traces in work zone one .....	207
Figure 4.13 Plots of mean speed, confidence interval, and functional boxplot in work zone one.....	210
Figure 4.14 Vehicle acceleration in work zone one with left lane closure and a DMS after the first warning sign.....	212
Figure 4.15 Plots of mean speed, confidence interval, and functional boxplot in work zone two.....	220
Figure 4.16 Vehicle acceleration in work zone two with left lane closure and a DMS after the lane merge sign.....	222
Figure 4.17 Plots of mean speed, confidence interval, and functional boxplot in work zone three.....	227
Figure 4.18 Vehicle acceleration in work zone three with left lane closure and a DSFS after the first warning sign.....	230
Figure 4.19 Plots of mean speed, confidence interval, and functional boxplot in work zone four .....	236
Figure 4.20 Vehicle acceleration in work zone four with a right lane closure and a DSFS after the first warning sign .....	238
Figure 4.21 Plots of mean speed, confidence interval, and functional boxplot in work zone five .....	243
Figure 4.22 Vehicle deceleration in work zone five with a lane shift and both shoulders closure.....	246

Figure 4.23 Plot of mean speed and standard deviation at safety features..... 252

Figure 4.24 Mean of deceleration profiles for studied work zones and involved drivers  
by gender ..... 256

## LIST OF TABLES

Table 1.1 Crash critical reasons attributed to driver, vehicle, and environment .....	13
Table 1.2 Organization of the Virtual Scenarios (Sommers and McAvoy, 2013).....	21
Table 2.1 Crash critical reasons attributed to driver, vehicle, and environment .....	48
Table 2.2 Additional variables contributing factors .....	61
Table 2.3 Variable definition and coding for the model.....	63
Table 2.4 Logistic regression model parameter estimate for work zone event outcome.....	64
Table 2.5 Odds ratio for work zone event outcome predictors.....	65
Table 3.1 Extracted work zone characteristics from forward videos.....	83
Table 3.2 List of work zone characteristics for the sample work zones .....	85
Table 3.3 Number of traces per driver in all work zones.....	86
Table 3.4 Work zone features extracted from forward videos.....	87
Table 3.5 Recommended advanced warning sign minimum spacing (FHWA 2009) .....	95
Table 3.6 Summary of multiple changepoints detected in work zone 1 .....	116
Table 3.7 Summary of multiple changepoints detected in work zone 2.....	120
Table 3.8 Summary of multiple changepoints detected in work zone 3 .....	124
Table 3.9 Summary of multiple changepoints detected in work zone 4.....	127
Table 3.10 Summary of multiple changepoints detected in work zone 5.....	131
Table 3.11 Summary of multiple changepoints detected in work zone 6.....	134
Table 3.12 Summary of multiple changepoints detected in work zone 7.....	137

Table 3.13 Summary of multiple changepoints detected in work zone 8.....	140
Table 3.14 Summary of multiple changepoints detected in work zone 9.....	143
Table 3.15 Multiple changepoint results for all work zones.....	152
Table 4.1 Extracted work zone characteristics from forward videos.....	186
Table 4.2 List of work zone characteristics for sample work zones.....	188
Table 4.3 Work zone features extracted from forward videos.....	189
Table 4.4 Recommended advanced warning sign minimum spacing (FHWA 2009) .....	205
Table 4.5 Change in mean speed and standard deviation reacting to work zone one safety features.....	214
Table 4.6 Change in mean speed and standard deviation reacting to work zone two safety features.....	224
Table 4.7 Change in mean speed and standard deviation reacting to work zone three safety features.....	232
Table 4.8 Change in mean speed and standard deviation reacting to work zone four safety features.....	240
Table 4.9 Change in mean speed and standard deviation reacting to work zone five safety features.....	248

## NOMENCLATURE

AASHTO	American Association of State Highway and Transportation Officials
AIC	Akaike Information Criterion
ANOVA	Analysis of Variance
BIC	Bayesian Information Criterion
BS	Binary Segmentation
CL	Closed Lane
CMS	Changeable Message Sign
CPT	Changepoint
CTRE	Center for Transportation Research and Education
DAS	Data Acquisition System
DMS	Dynamic Message Sign
DOT	Department of Transportations
DSFS	Dynamic Speed Feedback Sign
DSS	Dynamic Speed Sign
FDA	Functional Data Analysis
F	Female
FHWA	Federal Highway Administration
FSZ	Floating Speed Zones
GPS	Geographic Positioning System
HZ	Hertz
IRB	Institutional Review Board
ITS	Intelligent Transportation System

M	Male
MUTCD	Manual of Uniform Traffic Control Devices
NIH	National Institute of Health
NHTSA	National Highway Traffic Safety Administration
NDS	Naturalistic Driving Study
NWZSC	National Work Zone Safety Information Clearinghouse
OL	Open Lane
OP	Optimal Partitioning
PELT	Pruned Exact Linear Time
RSDB	Radar Speed Display Board
RID	Roadway Information Database
SHRP 2	Strategic Highway Research Program 2
SIC	Schwarz Information Criterion
SN	Segmentation Neighborhood
TCP	Traffic Control Person
TTCD	Temporary Traffic Control Devices
VMS	Variable Message Sign
VTI	Virginia Tech Transportation Institute
WZ	Work Zone



## ACKNOWLEDGMENTS

The successful completion of this research would not have been possible without the encouragement, sacrifice, and support of so many. I am first and foremost grateful to almighty God whose presence and guidance is always evident.

I would like to sincerely thank my major professor, Omar Smadi, for his advice, continued support, and friendship throughout this research and my work at Institute for Transportation at Iowa State University. Without his generous guidance, expertise, and broad knowledge, this research would not have been completed. I would like to thank my committee members, Keith Knapp, Jing Dong, Alicia Carriquiry and Jennifer Shane for their constructive suggestions in my oral defense. Also, I need to thank Shauna Hallmark for being a member of my committee and her contribution to the research.

My appreciation is extended to the Institute for Transportation at Iowa State University and its staff for supplying the technological and administrative resources necessary to complete this manuscript. I wish to thank my colleagues and office mates for their support and encouragement. I am grateful to Zach Hans, Skylar Knickerbocker, Raju Thapa, Amrita Goswamy, Yalin Rao, and Nate Garton for their help, suggestions, and input on various stage of this research.

I would like to thank my previous advisor and a longtime friend Dr. Reginald Souleyrette for his continuous and unconditional support and valuable advice from the day one I started the graduate program until today. He has always inspired me to continually reach for higher goals and guided me toward the right path. His leadership has helped me grow into my potential. I would not be where I am today without his guidance.

I wish to express my especial gratitude to my close friend Colleen Hamilton for assisting me in editing the text. I have always benefited from her moral support and encouragement.

My sincere gratitude is expressed in the memory of my parents whose constant moral support, love, prayers, and encouragement made me able to face and prevail hard challenges in my life. They gave up so much for providing better opportunities for their children. I would also express my deep appreciation to my father-in-law for his high moral standards and values for humanity, integrity, and dedications. I also wish to admire my mother-in-law to be the symbol of kindness, patience, and forgiveness.

Finally, I am forever grateful to my family, my wife, Leyla, and my children Ali and Fatimah, who made this all possible through their unconditional love, support, sacrifice, and needed words of encouragement when times were tough. Ali and Fatimah are inspiring, motivating, and amazing me every day. Leyla has always inspired, encouraged, and supported me to encounter any obstacle in my life. She has been the main source of inspiration and motivation from the start to the end of this journey. I could not have done this without her. Words cannot express my sincere gratitude and love for her.

## ABSTRACT

The presence of a work zone increases disturbances to traffic flow and produces high cognitive workloads for drivers, which can increase the safety risks. There was an increase of about 11% in work zone-related fatalities from 2010 to 2014 despite a small decrease in non-work zone-related fatalities in the U.S.

A number of studies concluded speeding and distractions are the main unsafe driver behaviors contributing to work zone crashes. Federal Highway Administration (FHWA) crash facts indicated speeding as a contributing factor for 28% of work zone crashes in 2014. A series of countermeasures have been used to get drivers' attention to comply with work zone conditions. There is limited information about which safety features are the most effective in accomplishing this goal. The effectiveness of safety features can sometimes vary due to driver behavior that has not been truly investigated due to limited information in our traditional crash data.

The Naturalistic Driving Study (NDS) data, developed by the Strategic Highway Research Program (SHRP) 2 provides a unique opportunity to observe actual driver behavior, to identify main contributing factors associated with crashes and near-crashes, and to understand how drivers negotiate work zones.

The aim of this dissertation is to develop models that provide a better understanding of driver behavior in work zones. The additional objective is to determine the most effective safety features to get drivers' attention in reducing their speed in work zones. The task was accomplished by conducting three studies.

The first paper developed a logistic regression model using a number of explanatory variables which included driver behavior, work zone characteristics, and environmental conditions to predict the crash/near-crash event outcome.

In the second paper, the speed trajectory time series data were used to develop models to accurately and efficiently estimate the location of changepoint in mean speed reacting to safety features utilized in work zones to encourage safe driving.

The final paper utilized the methods of functional data analysis to understand and analyze driver behavior interacting with safety features applied in work zone with various characteristics. The methods were used to identify the effectiveness of various safety features.

## CHAPTER 1. GENERAL INTRODUCTION

A work zone is defined as a segment of road where construction activities take place. There are a large and increasing number of road segments under construction and maintenance as highway system gets older. The presence of a work zone increases disturbance to traffic flow and produces high cognitive workloads for drivers which can increase the safety risks. There was an increase of about 11% in work zone-related fatalities from 2010 to 2014 despite a small decrease in non-work zone-related fatalities in the U.S. (1) Work zone safety is a major concern for construction workers, travelling publics, and transportation safety professionals. Work zone impacts on safety creates a strong need to protect road users and construction workers.

### 1.1 Contributing Factors to Work Zone Safety Problem

There are a large number of factors contributing to work zone crashes but it is believed that the major contributing factors are speeding, inattentive driving, and other risky driver behaviors, such as following too closely. A number of countermeasures have been proposed and utilized to get drivers' attention and encourage safe driving in work zones, but there is limited information about the effectiveness of those countermeasures since driver behaviors are not clearly known for several reasons.

The traditional method is to use the crash data to determine and evaluate crash causation, but crash data only include limited detail about the situation and does not address human contributing factors effectively. The level of detail provided on the crash report is dependent on the attending officer and his/her interpretation of the crash situation. As a result, in some cases work zone traffic control may be present but unrelated to crash because

the work zone was not active at the time of the crash, but crash coded as work zone related. In other cases, the impact of a work zone extends beyond the work zone boundaries such as during congestion or queuing, but since the crash does not occur within the defined boundaries, it is not reported as a work zone-related crash.

As the past research identified driver as the major contributing factor in crashes, there is a little information on crash reports detailing how the driver contributed to the work zone crash. Most driver behavior information relies on driver's own statement or witness testimonies, which could be inaccurate for various reasons, resulting in insufficient information.

## **1.2 The Opportunity of Utilizing Naturalistic Driving Study**

The Naturalistic Driving Study (NDS) data, developed by the Strategic Highway Research Program (SHRP) 2, provides a unique opportunity to observe actual driver behavior and understand how they interact with roadway, vehicle and traffic environment. The NDS is referred to as an unobtrusive method of observation which studies driver's daily driving behavior in a natural setting environment without any experimental control (2). In NDS, no driving instructions were provided to drivers as how, when, and where to drive, resulted in unbiased, reality-based data. That is why this study provides a unique opportunity to observe how drivers naturally interact with roadway, traffic environment, their own vehicle, and other road users.

Technological advancement in recent years enables researchers to conduct such a huge scale naturalistic driving study. Many variables in this study were collected at high frequency of 10 Hz, which corresponds to 10 observations per second. The Data Acquisition System (DAS) in this study, which consists of video cameras, forward radar, Geographic

Positioning System (GPS), accelerometers, vehicle network information, eye tracking, and data storage system, was utilized to collect a massive volume of time series data.

The NDS can be utilized to observe drivers' daily normal driving behavior in order to understand some underlying causes of crashes and the effectiveness of safety measures. In addition, using forward roadway views from NDS, enables us to determine if a safety critical event (crash or near-crash) is actually work zone-related. Consequently, SHRP 2 NDS dataset can be utilized to identify how drivers negotiate work zones.

### **1.2.1 Background on SHRP 2 Naturalistic Driving Study**

The SHRP 2 NDS is the largest and most comprehensive driving-based research study ever conducted. NDS is designed to observe driver's daily driving behavior in a natural setting environment with no experimental control. The Virginia Tech Transportation Institute (VTTI) led this project implementation and coordination. More than 3,100 female and male drivers aged 16 to 98 were recruited in six unique and geographically distributed sites (New York, Florida, Washington, North Carolina, Indiana, and Pennsylvania). The participants' vehicles were equipped with Data Acquisition System (DAS), which consists of sensors, cameras, Geographic Positioning System (GPS), vehicle network, lane tracking system, accelerometers, eye-tracking system, and data storage. The sensors of DAS collected data such as speed, GPS, and acceleration while four cameras collected forward, rear, driver face, and over the shoulder videos. Over 3,100 drivers had over 5 million trips over the study period of more than two years, resulting in over 30 million data miles and 4 million gigabytes of data. NDS collected a variety of variables regarding driver's daily driving behavior without any experimental control. Most of the variables were collected at high frequency (10 HZ), which is every 0.1 second (2).

### **1.2.2 Background on SHRP 2 Roadway Information Database**

The Roadway Information Database (RID) was conducted to collect roadway information data for the roads driven by drivers in SHRP 2 NDS. The Center for Transportation Research and Education (CTRE) at Iowa State University led the implementation and coordination of the project, which used mobile data collection vans to collect about 12,500 center line miles of roadway data elements in the six NDS sites. In addition, other existing roadway data from government, public and private sources, as well as supplemental data, were utilized to populate a roadway element dataset linkable to NDS trips to support a comprehensive safety assessment of driver behavior. The identified roadway data elements included information on roadway alignment, number of lanes, lane type and width, intersection types and location, lighting, signage, median type, barriers, rumble strips, and other features. The RID integrated 511 data provided by states with roadway data collected throughout NDS study locations. The integrated 511 data was the primary source of identifying work zone locations and duration (3).

### **1.3 Previous Research**

There have been considerable efforts in past few decades to address safety issues in work zones. Previous research has addressed driver, environment, and roadway/work zone characteristics which have contributed to work zone crashes. Crash types, locations, and contributing factors in work zones also have been investigated, along with the effectiveness of some work zone safety measures. The objective of this literature review is to characterize the nature of work zone crashes and review countermeasures and their effectiveness used in the past research.



### 1.3.1 Work Zone Crash Characteristics

Several studies were undertaken to investigate the safety of roadway work zones compared to non-work zone locations and concluded that crash rates at work zones are significantly higher than non-work zone locations (4-9, 53).

Rouphail et al. (1988) compared before and after construction crash rates on freeway work zones in Illinois. The crash rate during the construction period increased by an average of 88% compared to the before period. The crash rate decreased by an average of 34% for the after period compared to the construction period (4).

Garber and Woo (1990) study found a 57% and a 168% crash increase on multi-lane and two-lane highway work zones compared to non-work zone periods in Virginia respectively (7).

A more recent research by Silverstein et al. (2015) used a binary probit model to compare work zone and non-work zone crashes. The study results indicated both rear-end and sideswipe collision are more probable causes of fatalities in work zones compared to non-work zones. The study also concluded clear conditions, daylight, and straight roadway segments increased the possibility of a crash in the work zone (53).

Mixed results have been demonstrated on the severity of crashes in work zones compared to non-work zone conditions. There were studies which concluded that crashes in work zones are relatively less severe than non-work zone crashes (4, 5, 10) and other studies that concluded that work zone crashes were more severe compared to non-work zone crashes (8, 9). In addition, there were studies which found no significant difference between work zone and non-work zone crashes (6-7).

Akepati (2010) investigated work zone crash data for the Smart Work Zone

Deployment Initiative (SWZDI) region (Iowa, Kansas, Missouri, Nebraska, and Wisconsin) to determine characteristics and contributing factors of those crashes. About 75% of crashes occurred during daylight, and 69% with no adverse weather conditions. A majority of crashes occurred on a dry road surface (84%). Crash statistics showed 27.2% were injury crashes, with 296 people died as a result of those crashes for the five-year period studied.

Crashes with other moving vehicles were about 73%, of which 43% and 15% were rear-end collisions and angle collisions, respectively (13).

Regression models were utilized to predict the expected number of crashes at rural two-lane highway work zones looking at crashes on upstream and inside the work zones separately (Venugopal and Tarko, 2000). The models indicated the type, duration, length, and volume of the work zones were significant factors in predicting the number of crashes. The study results revealed shorter work zones have higher number of upstream crashes compared to longer work zones (14).

Li and Bai (2006) studied Kansas work zone crashes from 1992 to 2004, to compare fatal and injury crash characteristics. The results of this study showed head-on was the main collision type for fatal crashes, and rear-end was the major type for injury crashes (15).

Male drivers were involved in 75% of fatal crashes and 66% of injury crashes in Kansas. Drivers between 35 and 44 years old, and older than 65, are the high-risk driver groups in work zones. Male drivers aged 25 to 64 were involved in 64% of all work zone crashes, which might be due to the fact that this age group tends to drive more so they have higher exposure to the work zones (15).

A study by Li et al. (2012) on truck-related crashes in Kansas highway work zones indicated that trucks were involved in a high percentage of fatal crashes while passenger cars

were mainly involved in injury crashes. About half of the truck drivers were at fault in work zone fatal crashes. The maneuver before the crash for most of the truck drivers was straight following. The rear-end crash was the dominant type of crash for all severity types (16).

A research conducted by Ulman et al. (2006) identified the effects of night work activity on work zone crashes in Texas. They investigated the change in crash likelihood for active and inactive night and day construction work. Results showed higher crashes for active work zones for both night and day-times than during an inactive work zone periods. There was a higher percentage of rear-end crashes at night-time active work zones (17).

Arditi et al. (2007) investigated crash characteristics of highway work zones by comparing daytime and nighttime construction activities. They studied fatal crashes to identify if there was any difference between night time and daytime construction. The lighting and weather conditions were included in the study as control parameters to determine their effects on frequency of fatal crashes happening in work zones. The Kruskal-Wallis test was conducted to find if the number of fatal crashes and the number of people and workers involved in construction zones crashes significantly differ from nighttime to daytime conditions. This study concluded nighttime construction was more dangerous than daytime construction; however, weather condition variables had limited effects on this result (18).

### **1.3.2 Work Zone Crash Types**

A number of research projects have examined crash data to identify crash types in work zones. The rear-end crash has been identified as the most predominant work zone crash type of all crashes by the majority of previous studies (4, 6-7-9).

Rouphail et al. (1988) found rear-end crashes were increased by 50% during a roadway construction period. Hall and Lorenz research demonstrated rear-end crash percentage increased from 9 to 14% during construction (4).

Garber and Zhao (2002) concluded rear-end and sideswipe crashes were the most frequent crash types at the advanced and transition areas of work zones while fixed object and angular crashes were more dominant at the work area and termination area (8).

Rear-end work zone crashes in Singapore were assessed by Meng and Weng (2010), which found rear-end crash risks increased with lane traffic flow rate and heavy truck proportion. The study also revealed higher rear-end crash risks for work zones with lane closures and suggested early merge as an effective method to reduce rear-end crash risk at merging point (21).

Daniel et al. (2000) identified head-on, angle, and single vehicle as the predominant types of fatal crashes in work zones (22).

Most fatal crashes are multi-vehicle crashes. Head-on, angle-side impact, and rear-end are the three most frequent collision types for the multi-vehicle crashes (7, 15).

Li and Bai (2008) compared characteristics of fatal and injury crashes work zones in Kansas. The study revealed head-on collisions as the dominant type of fatal crashes while rear-end was the major crash type for injury crashes (19).

Garber and Woo (1990) concluded work zone crashes were more likely to involve multiple vehicles than non-work zone crashes (7).

### 1.3.3 Work Zone Crash Locations

A work zone consists of advanced warning area, transition area, buffer area, activity area, and termination area. There are multiple research projects which evaluated the distribution of crashes within these areas.

Activity area is the predominant location for all types of work zone crashes (8-9, 11-12). However, other research concluded differently. Nemeth and Migletz (5) study found higher crashes occurred in the buffer area. Srinivasan et al. revealed higher crash proportion in the advanced warning area (20).

Garber and Zhao (2002) concluded that rear-end crashes are the predominant crashes within the work zone advance warning area, transition area, and activity area. However, angle crashes are significantly higher at the termination area (8).

Chambless et al. (2002) studied typical characteristics of work zone crashes in Alabama, Michigan, and Tennessee and revealed that 63% of work zone crashes take place on interstate, US, and state highways, as compared to 37% of non-work zone crashes. The work zone crashes on 45 and 55 mph speed zones were 48% as compared to 34% of non-work zone crashes (23).

Some studies also revealed that most work zone crashes occurred on rural interstate and state highways (9, 25). However, another study revealed contradictory findings. The Garber and Zhao (8) study revealed that urban highways have a higher proportion of work zone crashes compared to rural highways. Jin et al. (2008) study found no relationship between road functional class and crash distribution in work zones (24). The majority of fatal and injury work zone crashes occurred within 51-60 mph speed limit zones (15).

### 1.3.4 Work Zone Crash Contributing Factors

Many studies have been conducted to analyze work zone crash characteristics and their contributing factors. The findings of these studies indicate work zone crashes in different spatial locations share some common features and contributing factors.

Li and Bai (2006) concluded inattentive driving, misjudgment, and disregarding traffic control are the top contributing factors for work zone fatal crashes (15).

Chambless et al. (2002) study revealed 27% of work zone crashes were due to misjudging stopping distance and following too close in Alabama, Michigan, and Tennessee as compared to 15% for non-work zone crashes (23).

Lindly et al. (2002) similarly identified misjudging stopping sight distance and following too closely are the predominant causes of work zone crashes in Alabama according to 1994-1998 crash data. The study also found the ratio of drivers speeding in work zones were higher than non-work zone drivers (25). The results of some other studies also indicated following too close as the dominant contributing factor in work zone crashes (6, 9).

Kumar et al. (2015) utilized a qualitative approach by interviewing 66 construction workers from several work zones in Queensland, Australia, to identify nature and contributing factors in work zone crashes. The survey results reveal excessive vehicle speed, driver aggression towards road workers, and driver distraction as the major contributing factors to work zone crashes (26).

Li and Bai (2006) revealed driver inattention is the major cause for both fatal and injury crashes in work zones (15).

A number of studies identified speed as a major contributing factor to work zone crashes (8, 27-29). The Allpress et al. (2010) study found excessive speed as a major

contributing factor for increasing a driver's risk of crash involvement at work zones in New Zealand (27). Sommers and McAvoy (2013) research revealed speed variance and congestion are typical causes of rear-end crashes in work zones (29).

Bryden et al (1998) study showed impact with work zone traffic control devices caused about 33% of all work zone crashes (30).

### **1.3.5 Temporal and Environmental characteristics**

Environmental factors such as lighting, weather, and surface conditions can all contribute to unsafe driver behaviors in work zones.

Work zone crash data for Smart Work Zone Deployment Initiative (SWZDI) was investigated by Akepati (2010) and revealed 75% of crashes occurred during daylight, and a majority of crashes (84%) occurred on a dry road surface (13). Two other earlier studies found work zone crashes were increased at night due to the higher possibility of lane closures (10, 17).

A study by Arditi et al. (2007) using the Kruskal-Wallis test was conducted to find if the number of fatal crashes and the number of people and workers involved in construction zones crashes significantly differ in nighttime versus daytime conditions. This study concluded nighttime construction is more dangerous than daytime construction; however, weather condition variables have a limited effect on this result (18). In contrast, Dissanayake and Akepati (2009) found daylight and good weather are the most probable conditions for work zone crashes (33).

The daytime off-peak hours (10:00 a.m. – 4:00 p.m.) are the most hazardous time periods in work zones (15, 26).

In another study by Hall and Lorenz (1989) inclement weather conditions and bad roadway surface were found to have a significant impact on road work crashes (6).

### 1.3.6 Driver Characteristics

Past research indicated driver error as the main contributing factor to work zone crashes, noting that speeding, inattentive driving, speed too fast for the condition, and following too closely were the most frequent driver errors associated with severe work zone crashes. Research on driver characteristics and behaviors found age, gender, and risky driving behavior such as speeding and aggressive driving are all contributing factors to highway work zone crashes. A number of research quantified the proportion of human factors as the major contributing factor to more than 93% of all crashes on roadways (31, 32).

Rumar et al. research (1985) studied crash causation and showed the proportion of drivers, roadway, and vehicles that were major contributing factors of crashes through the well-known Venn diagram as shown in Figure 1.1.

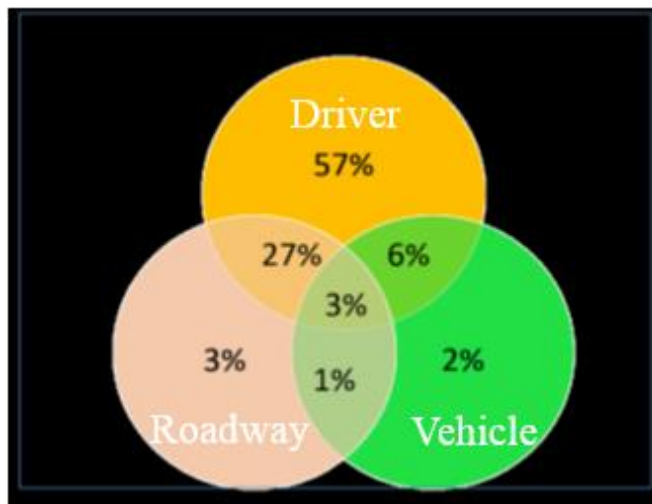

Figure 1.1 Proportion of crash causation (Rumar et al., 1985)



As mentioned before, the study found human or driver error to be the contributing factor to 93% of crashes, while roadway and vehicle factors with 34 and 12%, respectively, have a much lower proportion of crash causation.

The proportions of crash causation mainly attributed to drivers studied by Rumar et al., were confirmed more recently by the NHTSA study of 2015. This study was based on the National Motor Vehicle Crash Causation Survey (32). Table 1.1 shows the result of critical reasons attributed to drivers, vehicle, and the environment.

**Table 1.1 Crash critical reasons attributed to driver, vehicle, and environment**

Critical Reason Attributed to	Estimated	
	Number	Percentage
Driver	2,046,000	94%
Vehicle	44,000	2%
Environment	52,000	2%
Unknown	47,000	2%
<b>Total</b>	<b>2,189,000</b>	<b>100%</b>

As shown in the table, 94% of related critical reasons for crashes were attributed to drivers, vehicle and the environment with 2% attributed to very minimal crash causations.

A number of prior research studies identified the human factor as the main contributing factor in roadway crashes (31, 32, 50-51). Although driver behavior has contributed significantly to crashes, it is the least understood factor. This is mainly due to limited information about driver behavior in our traditional crash data. Also we have many unreported and under-reported crashes which creates a huge limitation on our existing crash database.

### 1.3.7 Effectiveness of Work Zone Safety Measures

As many studies identified excessive speed as the predominant contributing factor to work zone crashes, effective speed control in work zones has become a major challenge for engineers and road construction communities.

Research identifying the effectiveness of traffic control devices in work zones indicated the most effective measures in reducing mean speed and speed variance in work zones are speed display sign, flaggers, and automated radar detections with citations issued to vehicle owners. On the other hand, pavement markings, signs, and other standard traffic control devices were found to be ineffective in reducing vehicle speed in work zones (34, 42, 44-45).

The Iowa Department of Transportation (Iowa DOT) utilizes various measures to reduce speed in work zones by setting up equipment in construction segments to evaluate the effects of speed reduction. Methods used to reduce speed in work zones were running speed indicators, speed limit regulation signs, speed limit advice signs, changeable message signs, and a crackdown against speeders which was found to be the most efficient way to slow down the traffic. Although a crackdown against speeders was the most efficient method, it was not cost effective, so the combination of changeable message signs and current speed indicators was the preferred method for speed regulation (34).

Kamyab and Storm (35) conducted a research to find the effectiveness of fluorescent yellow-green background for vehicle mounted work zone signs, noting that, “moving work zones have fewer traffic control devices than stationary work zones and provide no buffer space for vehicles that encroach on work zones.” To improve the safety of moving operations, the Iowa DOT created a six-inch fluorescent yellow-green (FYG) background for

work zone signs mounted on the back of work zone vehicles. The purpose of this study was to investigate the effect of the sign's improved visibility in inspiring drivers to make an early merge to the open lane prior to a lane closure. Data was collected on two sites on US 30, mile post 161, near Boone, and two sites on I-35, milepost 101 and 118. Results of this study revealed 5 and 2% reduction of right lane traffic proportion in the after condition on US 30 sites and I-35 sites, respectively.

As exceeded speed and speed differential were identified as significant contributing factors to crashes (33, 36, 43), several studies attempted to assess safety methods that would reduce speed in work zones (33, 36, 43). Maze et al. specified combinations of work zone speed limit with other regulatory signs could be effective in reducing speed (36).

A number of research studied the effect of speed monitoring displays in getting drivers' attention to reduce their speed and collectively confirm the effectiveness of speed display systems in reducing the average speeds in work zones (36-38).

A study was conducted by Vicki and Jonathan (1999) to investigate the work zone crash countermeasures identifying effective countermeasures to reduce work zone crashes in Arizona. They used crash data collected by the Accident Location Identification Surveillance System (ALISS) which includes crashes that occurred near three locations: under-construction locations where through traffic was allowed and where traffic was detoured within the work zone, existing temporary lane closure areas, and under repair areas. The crashes were analyzed based on the severity and on the conditions of when the crashes took place. Based on the study results, a number of different countermeasures were recommended in order to reduce work zone crashes. Police presence in advance warning areas of work zones which reduced vehicles' speed, speed limit enforcement in work zones by displaying

license plate numbers, changeable message signs, and radar-activated sound systems were recommended countermeasures by researchers in this study (39).

Suk-Ki Lee et al. (2012) studied safety problems associated with two-lane highway construction projects in Korea which requires full or partial road closures. Two-way delays and poor traffic control are the main issues of these types of road construction. Typically flagging is used to control work zone traffic on a two-way highway by closing one way and changing traffic movements. One or two-way delays, along with poor driver visibility, are the main issues with flagging control which may result in serious crashes in work zones. To minimize these problems, they used actuated traffic control with fixed and dynamic all red phases to control traffic movement. They analyzed each control method based on average control delay per vehicle to determine the effectiveness and the number of conflicts in a work zone to assess safety. Actuated traffic control with dynamic all red was found the most effective way of signal controlling with both safety and mobility considerations on two-way highways (40).

Many studies have examined the effect of police enforcement and Intelligent Transportation System (ITS) applications on vehicle speeds in work zones. Avrenli et al. (2011) explored effects of police enforcement and ITS implementation on work zone speed flow curve and capacity. They collected three sets of data in work zones on I-55 close to Chicago. The first set collected when traditional signage in work zones suggested by Manual of Uniform Traffic Control Devices (MUTCD). The second set added police enforcement to the traditional signage. The third set added Speed Photo Enforcement (SPE) to recommended signage by MUTCD. The results revealed both police enforcement and SPE significantly changed the speed flow rate in work zones compared to only traditional MUTCD signage.

Implementing police enforcement and SPE both lowered the speed in the uncongested part of the speed flow curve, and caused a small capacity reduction of about 50 and 100 passenger car per hour, per lane, for police enforcement and SPE, respectively (41).

To improve compliance with work zone speed limits, Brewer et al. (1984) conducted a field study to identify effective measures to inspire drivers to observe the posted speed limits in work zones. Three devices were used to conduct this study, including a speed display trailer, changeable message sign with radar, and orange-border speed limit sign. Devices were tested at two sites in Texas including a rural interstate highway and an urban U.S. highway. Field study results using these devices indicated that speed display devices have a very high potential for speed reduction and compliance improvement. It has been revealed that orange borders significantly improve speed limit signs' visibility, but don't have a measurable effect on compliance. Results indicate drivers are likely to drive as fast as they feel comfortable regardless of posted speed limit, if there is no active enforcement (42).

Studies on the effectiveness of changeable message sign (CMS) indicated its effectiveness in reducing speeds and informing traffic about upcoming work zone and are more effective than traditional work zone warning sign (42, 46).

A study by Zech and Mohan (2008) measured the effect of three commonly used CMS in reducing vehicle speed in work zones. The study recorded the speed of 180,000 vehicles on Interstate 90 and found that the "WORK ZONE/ MAX SPEED 45 MPH/ BE PREPARED TO STOP" message was effective to reduce the vehicle speeds between 3.3 and 6.7 mph. The study concluded a properly selected CMS message can significantly reduce traffic speeds in work zones (47).

Li and Bai (2011) used changeable message signs at 250, 750, and 1,250 feet from work zones. Displaying “WORK ZONE AHEAD SLOW DOWN” signs revealed that changeable message signs will be more effective in reducing vehicle speed if they are placed between 556 to 575 feet from the work zone. Alternative messages, including “YOUR SPEED IS ## MPH,” changing to “SLOW DOWN,” followed by “MIMIMUM FINE \$200” had positive effects on getting drivers’ attention to reduce their speed. The results indicate the percentage of drivers driving 5, 10, 15, 20, and 25 miles over the speed limit were reduced by 20, 20, 10, 3, and 0.3%, respectively (48).

The presence of a speed photo enforcement van in a work zone with the same function as red light cameras, was successful in lowering vehicle speed from 6.4 to 8.4 mph. In a different study, it was effective reducing the speed by as much as 7.9 and 6.6 mph for cars and heavy vehicles, respectively (49).

The implementation of speed trailers along the side of an urban road, which flash the speed if the vehicle is traveling over the speed limit, was effective in reducing speeds by up to 2 mph (49).

Allpress et al. (2010) evaluated the effect of “excessive speed” using two intervention processes which were designed to control traffic speed entering the work zone area in New Zealand. They realized “excessive speed” was a major contributing factor in increasing a driver’s risk of crash involvement at work zones. Their research focused on “perceptual countermeasures” which are “manipulations of the roadway or roadside environment designed to increase drivers’ estimation or feeling of speed.” Lane width reduction is a common method of the “perceptual countermeasure” application. The aim of lane width reduction is to restrict the amount of usable road by introducing road edge rumble strips or

orange cones. It was even demonstrated that narrowing a driver's perception of lane width in a driving simulator lead to a decrease in driving speed. The work zone set up consisted of an orange road work warning sign at 150 m and a 50 km/h speed limit sign at 75 m from the start of the work zone. The work zone intervention layout is shown in Figure 1.2.

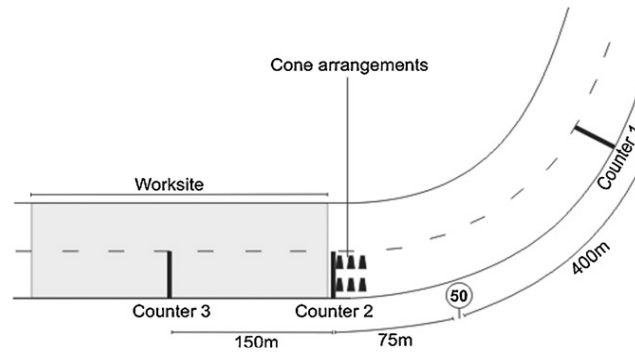

**Figure 1.2 Work zone intervention layout (Allpress et al., 2010)**

The work zone itself was 300 m. Three traffic counting devices were used. The first counter was laid at 400 m before the first speed reduction sign, the second was placed at the beginning of the road work, and the third was installed at midway of the work zone.

Two experimental intervention methods were testing the effectiveness of traffic cone arrangements both in equal spacing or decreasing spacing as shown in the figure 1.3.

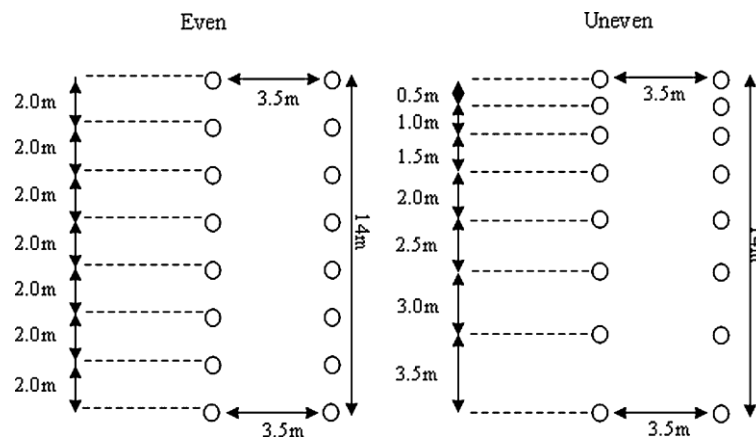

**Figure 1.3 Cone arrangements used in the study (Allpress et al., 2010)**

The study was designed to determine mean speed for even, uneven, and baseline conditions. Baseline data were collected when no interventions were in place, but to ensure road and environmental condition uniformity data report was limited to time ranges when experimental interventions were conducted. One-way ANOVA tests were implemented to identify the effects on mean speeds upon conducting each experiment. Results showed both even and uneven cone spacing intervention were highly effective and very convenient, although uneven spaced cones are more likely to reduce the number of speed related crashes in construction zones (27).

Sommers and McAvoy (2013) studied excessive speed to find the safest and most effective countermeasures to rectify speeding problems in work zones. The purpose of this study was to make drivers aware of the heightened risk in work zones by finding the safest and most effective countermeasure for speed reduction. This study along with some others tested Dynamic Speed Sign (DSS) as a passive enforcement measure, which can be trailer mounted or permanently mounted. Laser detectors can be used to measure the approaching vehicle speed and display it on the device. Studies revealed when DSS are used in work zones, travel speed can be reduced by as much as 5 mph (29).

A study by Sommers and McAvoy (2013) selected twenty countermeasures for simulator testing and conducted laboratory controlled experiments to measure driver behavior and performance. Drivers were asked to drive five different scenarios for 10 minutes, taking a break in between, with each containing four countermeasures as shown in Table 1.2 (29).

Analyses of 20 countermeasures in reducing speed within construction zones in the virtual setup indicate the “presence of construction workers, construction vehicles, law



enforcement, speed photo enforcement, and shifting lanes” were the most effective approaches to reduce speed in construction zones. Also, three sets of rumble strips, concrete barriers, other channelizing strategies, and changeable message sign with speed reduction of less than 10 mph were the least effective methods reducing speeds in work zones

**Table 1.2 Organization of the Virtual Scenarios (Sommers and McAvoy, 2013)**

Scenario A	Scenario B	Scenario C	Scenario D	Scenario E
Variable Speed Limit Sign	Speed Trailer	Law Enforcement	Speed Trailer + Law Enforcement	Speed Photo Enforcement
Sequential Flashing Lights	Dynamic Message Sign	Changeable Message Sign	Monetary Fine	Emergency Flasher Traffic Control Device
4 sets of 3 Rumble Strips	Concrete Barriers	Other Channeling Devices	3 sets of 3 Rumble Strips	Optical Speed Bars
Highway Work Zone Billboard	Presence of Construction Workers	Lane Reduction (12' → 10' lane)	Shifting Lanes	Presence of Construction Vehicles

The vast majority of past research looked at the effectiveness of a single speed countermeasures in work zones. Hildebrand and Mason (2014) evaluated the effectiveness of safety measures in three different rural work zone with a semi-controlled environment in Canada. Speed data were collected at three spots, including 500 m upstream of the activity area, 75 m upstream of the activity area, and immediately adjacent to the activity area to approximate the speed profile of vehicles approaching the active area. The safety measures identified and tested were Floating Speed Zones (FSZ), Traffic Control Person (TCP),

Narrow Lanes, Radar Speed Display Board (RSDB), Variable Message Sign (VMS), and a Fake Police Vehicle. These traffic control measures were singularly and collectively evaluated to identify the most effective measure(s) in slowing the traffic through the identified work zones. The study concluded a combination of TCP and FSZ had the highest effect in speed reduction by 23 km/h. A Fake Police Vehicle and FSZ, and a combination of RSDB and FSZ, both made the traffic slow down by an average of 19 km/h (54).

### **1.3.8 Summary of Major Findings**

This section reviewed previous research regarding work zone crash characteristics and contributing factors to those crashes. A number of different research studies revealed contradicting results for the same work zone characteristics studied. Some studies revealed work zone crashes were more severe than non-work zone crashes while other found work zone crashes to be less severe. There were also studies which didn't find any significant difference between work zone and non-work zone crashes. There were also mixed results on the work zone crashes at night versus daytime. Some studies concluded construction is more dangerous at night compared to daytime, while other studies believed daytime and good weather condition are the most probable condition for work zone crashes.

There was also some disagreement on the most predominant location of work zone crashes. Some believed advance area as the predominant location of work zone crashes, while others found higher crashes occurred in the activity area, and still another study found the buffer area as the most probable location of work zone crashes.

However, there was strong agreement among many studies about the crash type, which found rear-end as the most predominant type of crash in work zones. Studies also found head-on to be the major collision type of fatal crashes, while rear-end was the main

crash type for injury crashes in work zones. Trucks were involved in more fatal crashes and passenger cars were involved in more injury crashes in work zones as some studies noted.

Also many study results concluded speeding, inattentive driving, following too closely, and misjudging stopping distance to be among the major contributing factors of work zone crashes. Also speed variance and congestion were attributed to rear-end crashes in work zones.

There are a large number of factors contributing to work zone crashes but it is mainly believed that the major contributing factors are speeding, inattentive driving, and other unsafe driver behaviors, such as following too closely. Although driver behavior has significantly contributed to the crash causation, it is the least understood factor attributed to crash causation. This is mainly due to limited information about driver behavior in our traditional crash data. Most driver behavior information relies on a driver's own statement or witness testimonies, which could be inaccurate for various reasons, indicating these factors are not very well understood.

A number of countermeasures have been proposed and utilized to get driver's attention and encourage safe driving in work zones, but there is limited information about the effectiveness of these countermeasures since driver behavior is not clearly understood.

The NDS data provide a unique opportunity to observe and model actual driver behavior and understand how they interact with roadway, vehicle, and traffic environment. The NDS can be utilized to develop models to provide insight into driver daily normal driving behavior in order to understand some underlying causes of crashes and to determine how drivers negotiate work zones.

## 1.4 Problem Statement

The funding of federal and state agencies has been allocated to preserve the existing highway network. As a result, more and more highway work zones have been established nationwide. Construction activities produce disturbances on regular traffic flows and creates dangerous conditions for both road workers and the traveling public. Work zones may introduce severe traffic congestions that can cause frustration and aggressiveness for drivers, and therefore increase the risk of traffic crashes in work zones. Improving work zone safety, while providing an acceptable mobility with minimal interruption of traffic flow to road users has become a major challenge for road safety professionals.

Considerable effort has been made by federal, state, local, and private agencies to improve safety and mobility of work zones. Federal Highway Administration (FHWA) and American Association of State Highway and Transportation Officials (AASHTO) have been initiating numerous programs and guidelines to improve work zone safety. Various projects have been developed and funded by state Department of Transportations (DOT) to improve work zone safety in their jurisdictions.

There has been extensive research conducted by different communities and concerned groups to address safety issues in work zones. Even with the extensive effort devoted by various institutions, there is no indication that safety improvements in work zones were satisfactory. Despite a slight decrease of about 1.2% in no-work zone crash fatalities and 3.8% decrease in fatality rates from 2010 to 2014, there was an increase of about 11% in work zone related fatalities nationwide (1).

To address work zone safety issues, clear understanding of the nature of work zone crashes and their contributing factors could be beneficial to engineers to select proper

measures that can minimize the negative impacts of work zones on traffic safety. Past research indicated crash data as the main source of analyses that have been widely used to evaluate crash causation and understand the contributing factors to work zone crashes. As the past research also indicates human factors as the major contributing factors to about 93% of crashes (Rumar et al., Salmon et al. 2005, NHTSA 2015), the work zone crash data have a lot of limitations in understanding the role of human factor in crashes. This may be one of the reasons why the recommendations from prior research have not satisfactory improved safety in work zones. The recent developments of SHRP 2 NDS allow us to observe daily driving behavior of drivers in work zones.

### **1.5 Purpose of the Research**

The objective of this research is to develop models which provide a better understanding of how drivers negotiate work zones, to determine the factors contributed to safety critical events, and to identify driver behaviors that contributed to rear-end, sideswipe, and other typical work zone crashes. A further objective is to create models to evaluate how drivers react to various safety measures and to identify the effectiveness of safety features. This information can be used to properly select countermeasures associated with the main contributing factors and provide the most effective safety measures in work zones to get drivers' attention to navigate the work zone safely. The ultimate objective of this research is to observe and understand driver behavior, which could help to reduce the number and severity of crashes in work zones. There are three research questions in this dissertation. The developed models will help to address these research questions.

## 1.6 Research Questions

The objective of this dissertation is to evaluate how drivers negotiate work zones through the analysis of SHRP 2 Naturalistic Driving data. There are three research questions in this dissertation. The first research question is an analysis of crashes and near-crashes in work zones using a logistic regression model. The second research question utilizes a Pruned Exact Linear Time (PELT) model to observe and model how drivers react to various safety measures introduced in work zones to attract drivers' attention. The third research question concentrated on the power of Functional Data Analysis (FDA) in converting discrete time series observation to a series of continuous functions to identify the effect of any individual safety feature to get drivers to slow down in work zones. The three research questions mentioned here will be discussed in more details in the following sections.

### 1.6.1 Research Question 1: What are the contributing factors to safety critical events in work zones compared to baseline (normal driving)?

This research question focused on the analysis of work zone crashes and near-crashes which was identified as Safety Critical Events utilizing SHRP 2 NDS data. The majority of the prior research relied on traditional crash data collected by the officer at the crash site and lacked human contributing factors, as what the driver was doing prior to the crash. The NDS data provide us with a number of important driver behavior variables, which help us to observe the driver behavior associated with safety critical events, and identify the contributing factors to safety critical events from the observed behavior. The crashes and near-crashes were obtained from the SHRP 2 InSight website by conducting query for construction-related events. In total 256 crashes and near-crashes were identified initially. The number then was reduced to 148 by observing the forward video images to verify if the

work zone was actually an active work zone. The criteria used for this purpose was lane closure, shoulder closure, lane shift, the presence of workers, and the presence of equipment, which created some disturbance to the traffic flow. A total of 1,171 baseline work zone related events also were identified from SHRP 2 InSight website. The purpose of the analysis is to investigate the characteristics of crashes and near crashes which were combined and defined as safety critical events and compare that to normal driving behavior (baseline) in work zones.

### **1.6.2 Research Question 2: Where drivers start to react to the presence of work zones and how they interact with various safety measures in work zones?**

Multiple changepoint models will be developed to analyze speed time series data in work zones. The objective of this research question is to assess how drivers react to the presence of work zones' advances warning sign, merge sign, lane closure sign, and other safety measures such as Dynamic Message Sign (DMS), Dynamic Speed Feedback Sign (DSFS), flashing arrow, and similar safety measures in work zones. These countermeasures tend to get drivers' attention to react to the signage and reduce their speed, which help them safely traverse the work zone area. It is therefore essential to find how drivers react to a set of safety measures throughout the work zone to identify the effectiveness of countermeasures. Due to the presence of multiple safety measures throughout the work zone, drivers may react differently to each or a combination of measures which creates a changepoint and collectively creates multiple changepoints.

Multiple changepoint analysis is a statistical tool designed to divide time series data into isolated segments to show the underlying properties of its source of isolation. The Pruned Exact Linear Time (PELT) method was used to identify the optimal number and locations of multiple changepoints in speed time series trajectories from quarter mile

upstream of the first work zone warning sign all the way through the work area. The ultimate purpose of the analysis is to find an effective safety measure layout and identify the most effective countermeasure.

### **1.6.3 Research Question 3: How drivers negotiate work zones and how effective are the safety features in getting drivers' attention?**

The objective of this research question is to expand the findings of research question 2 to observe where drivers start to react to the presence of a safety measure and to identify the effect of any individual safety feature throughout the work zone. A series of safety measures such as Dynamic Message Sign (DMS), Dynamic Speed Feedback Sign (DSFS), work zone speed limit sign, lane closure sign, and similar signs intended to get drivers' attention to reduce their speed and navigate the work zone safely. It is therefore essential to observe drivers' behavior directly from speed time series data collected at every 0.1 second. The significance of any individual safety feature can be quantified by utilizing functional data analysis methods.

## **1.7 Dissertation Organization**

This dissertation covers five chapters. Chapter 1 provided a background of the work zone safety issues. It also provided the review of previous literature in great depth to identify roadway construction safety-related issues, to find major type and locations of roadway construction crashes, and to explore main contributing factors associated with crashes in work zones. Furthermore, the major findings and the knowledge gaps of previous research are discussed in this chapter. Chapter 2 addresses the first research question by analyzing crashes and near crashes in work zones using SHRP 2 NDS data and developing logistic regression models. Chapter 3 presents the results of the multiple changepoint analysis models



on speed profile intended to accurately and efficiently estimate the location of changepoint in mean speed reacting to safety features in work zones. Chapter 4 intends to find where drivers start to react and to identify the effectiveness of any individual safety feature throughout the work zone by utilizing functional data analysis methods. Chapter 5 delivers the summary of major findings and contributions of this dissertation, limitations of the research, and recommendations for future research.

### 1.8 References

1. National Work Zone Safety Information Clearinghouse. Traffic Crashes in Work Zones. <https://www.workzonesafety.org/crash-information/workzone-fatalities/workzone-fatalitiesmotor-vehicle-traffic-crashes-2014/>. Accessed November 2016.
2. Dingus, T. A., Hankey, J. M., Antin, J. F., Lee, S. E., Eichelberger, L., Stulce, K., McGraw, D., Perez, M., Stowe, L. Naturalistic Driving Study: Technical Coordination and Quality Control. Virginia Tech Transportation Institute. Blacksburg, VA, 2014.
3. Smadi, O. SHRP 2 S-04A Roadway Information Database Development and Technical Coordination and Quality Assurance of the Mobile Data Collection Project. Presented at the 7th SHRP 2 Safety Research Symposium, Washington D.C., 2012.
4. Roupail, N. M., Yang, Z. S., and J. Fazio, J. Comparative Study of Short- And Long-Term Urban 23 Freeway Work Zones. Transportation Research Record 1163, pp. 4-14. Transportation Research Board, Washington, D.C., 1988.
5. Nemeth Z. A., and Migletz, D. J. Accident Characteristics Before, during, and After Safety Upgrading projects on Ohio's Rural Interstate System. Transportation Research Record 672, pp. 19-23. TRB National Research Council, Washington, D.C., 1978
6. Hall, J. W., and Lorenz, V. M. Characteristics of Construction-Zone Accidents. Transportation Research Record 1230, pp. 20-27 TRB National Research Council, Washington D.C., 1989.
7. Garber, N. J., and Woo, T. H. Accident Characteristics at Construction and Maintenance Zones in Urban Areas. Report No. VTRC 90-R12. Virginia Transportation Research Council, 1990.

8. Garber, N. J., & Zhao M. Distribution and characteristics of crashes at different work zone locations in Virginia. *Transportation Research Record*, 1794, pp.19-28. Transportation Research Board, Washington, D.C., 2002.
9. Pigman, J. G., and Agent, K. R. Highway Accidents in Construction and Maintenance Work Zone. In *Transportation Research Record* 1270, pp. 12-21. Transportation Research Board, Washington, D.C., 1990.
10. Ha, T. and Nemeth, Z.A., Detailed Study of Accident Experience in Construction and Maintenance Zones. *Transportation Research Record* 1230, pp. 38-45. TRB National Research Council, Washington D.C., 1995.
11. Akepati, S. R. and Dissanayake, S. Characteristics and Contributory Factors of Work Zone 23 Crashes. *Transportation Research Board 90th Annual Meeting*, Washington, D.C., 2011.
12. Salem, O. M., Genaidy, A. M., Wei, H. and Deshpande, N. Spatial Distribution and Characteristics of Crashes at Work Zones of Interstate Freeways in Ohio. In *Proceedings of the 2006 8 IEEE Intelligent Transportation Systems Conference*, Toronto, Canada, pp. 1642-1647, 2006.
13. Akepati, S. R., Characteristics and Risk Factors Associated with Work Zone Crashes. Kansas State University, Manhattan, Kansas, Master Thesis pp. 1-145, 2010.
14. Venugopal, S. and Tarko, A. Safety Models for Rural Freeway Work Zones. CD-ROM. Transportation Research Board, Washington D.C., 2000.
15. Li, Y., and Bai, Y. Fatal and Injury Crash Characteristics in Highway Work Zones. CD-ROM. Transportation Research Board of the National Academies, Washington, D.C., 2006.
16. Li, Y., Cheng, F, and Bai, Y. Characteristics of Truck-Related Crashes in Highway Work Zones. Ninth Asia Pacific Transportation Development Conference, Chongqing China, pp. 364-371, 2012.
17. Ullman, G. L., M. D. Finley, and B. R. Ullman. Analysis of Crashes at Active Night Work Zone in Texas. CD-ROM. Transportation Research Board of the National Academies, Washington, D.C., 2006.
18. Arditi, D., Lee, D. E., Polat, G. Fatal accidents in nighttime vs. daytime highway construction work zones. *Journal of Safety Research* 38, 399–405, 2007.
19. Li, Y., Bai, Y. Development of crash-severity-index models for the measurement of work zone risk levels. *Accident Analysis and Prevention* 40, 1724–1731, 2008.

20. Srinivasan, S., Carrick, G., Zhu, X., Heaslip, K., and Washburn, S. Analysis of Crashes in Freeway Work Zone Queues: A Case Study. Report No: 07-UF-R-S3. Transportation Research 44 Center, University of Florida, Florida, 2008.
21. Meng, Q., Weng, J. Evaluation of rear-end crash risk at work zone using work zone traffic data. *Accident Analysis and Prevention* 43 (4), 1291-1300, 2011.
22. Daniel, J., Dixon, K., and Jared, D. Analysis of Fatal Crashes in Georgia Work Zones. *Transportation Research Record: Journal of the Transportation Research Board* No. 1715, pp. 40 18-23, 2000.
23. Chambless, J., Chadiali, A. M., Lindly, J. K., and McFadden, J. Multistate Work Zone Crash Characteristics. *ITE Journal*, Vol. 72, pp46 – 50, 2002.
24. Jin, T.G., Saito, M., and Eggett, D. L. Statistical Comparisons of the Crash Characteristics on 15 Highways between Construction Time and Non-Construction Time. *Accident Analysis and 16 Prevention* 40(6), pp. 2015-2023, 2008.
25. Lindly, J., Noorjahan, S., and Hill, S. Identification of Potential Enhancements for Work Zone Safety in Alabama. UTCA Report Number 00465, University Transportation Center for Alabama, Tuscaloosa, Alabama, 2002.
26. Debnath, A. K., Blackman, R., and Haworth, N. Common hazards and their mitigating measures in work zones: A qualitative study of worker perceptions. *Journal of Safety Science* 72, 293–301, 2015
27. Allpress, J.A., and Leland Jr. L.S. Reducing traffic speed within roadwork sites using obtrusive perceptual countermeasures. *Accident Analysis & Prevention*, Volume 42, Issue 2, pp. 377-383, 2010.
28. Raub, R. A., Sawaya, O. B., Schofer, J. L. and Ziliaskopoulos, A. Enhanced Crash Reporting to Explore Work Zone Crash Pattern. Paper No.01-0166, Transportation Research Board, Washington D.C., 2001
29. Sommers, N. M., and McAvoy, D. S. Improving Work Zone Safety through Speed Management. Ohio State University, June 2013.
30. Bryden, J. E., Andrew, L. B., and Fortuniewicz, J. S. Work Zone Traffic Accidents Involving 36 Traffic Control Devices, Safety Features, and Construction Operations. *Transportation Research 37 Record: Journal of the Transportation Research Board* No. 1650, pp. 71-81, 1998.
31. Rumar, K., Evans, L. & Schwing, R. The Role of Perceptual and Cognitive Filters in Observed Behavior. *Human Behavior in Traffic Safety*, eds. Plenum Press, 1985.

32. National Highway Traffic Safety Administration, Traffic Safety Facts, Crash Statistics, February 2015.  
<https://crashstats.nhtsa.dot.gov/Api/Public/ViewPublication/812115>. Accessed 8/28/2017.
33. Dissanayake, S. and Akepati, S. R. Characteristics of Work Zone Crashes in the SWZDI 20 Region: Differences and Similarities. Mid-Continent Transportation Research Symposium, Ames, Iowa 2009.
34. Iowa DOT. Evaluation of work zone speed reduction measures, CTRE Management Project 99-44, Iowa Department of Transportation, April 2000.
35. Kamyab, A., and Storm, B. Fluorescent Yellow-Green Background for Vehicle-Mounted Work Zone Signs. Midwest States Smart Work Zone Deployment Initiative (MWSWZDI), Iowa Department of Transportation, Iowa, 2001.
36. Maze, T. H., Kamyab, A. and Schrock S. D., “Evaluation of Speed Reduction Measures. Center for Transportation Research and Education” Iowa State University, 2000.
37. Fontaine, M. D. and Hawkins Jr. G. Catalog of Effective Treatments to Improve Driver and Worker Safety at Short-Term Work Zones, Report No. FHWA/TX-01.1879-3, Texas Transportation Institute, 2001.
38. Pesti, G. and McCoy, P. T. Long Term Effectiveness of Speed Monitoring Displays in Work Zones on Rural Interstate Highways”, Paper No. 01-2789, Transportation Research Board, Washington D.C., 2001.
39. Vicki, W., and Jonathan, U. Effective Countermeasures to Reduce Accidents in Work Zones. Report No. FHWA-AZ99-467. Arizona Department of Transportation, Arizona, 1999.
40. Lee, S. K., Park, S. Y., Kim, D. N., and Lee, H. J. Estimation of Effectiveness of a Vehicle-Actuated Signal Control System on Work Zone Operations for a Two-Lane Highway. Procedia – Social and Behavioral Science, Volume 43, pp. 653-661, 2012.
41. Avrenli, K. A., Benekohal, R., and Ramezani, H. Traffic Flow Characteristics and Capacity in Police-enforced and Intelligent Work Zones, 6<sup>th</sup> International Symposium on Highway Capacity and Quality of Service Stockholm, Sweden June 28 – July 1, 2011.
42. Brewer, M. A., Pesti, G., and Schneider, W. Improving Compliance with Work Zone Speed Limits: Effectiveness of Selected Devices. Transportation Research Record 1948, pp. 67–76. Transportation Research Board, Washington, D.C., 2006.

43. Li, Y., Bai, Y. Highway Work Zone Risk Factors and Their Impact on Crash Severity. *Journal of Transportation Engineering*, 135(10), pp. 694–701, 2009.
44. Garber, N. J., and Patel, S. T. Control of Vehicle Speeds in Temporary Traffic Control Zones (Work Zones) Using Changeable Message Signs with Radar. In *Transportation Research Record 1509*. TRB, National Research Council, Washington, D.C., 1995.
45. Shaik, N. M., Sanford Bernhardt, K. L., and Virkler, M. R. Evaluation of Three Supplementary Traffic Control Measures for Freeway Work Zones. *Mid-Continent Transportation Symposium Proceedings*, Iowa State University, Ames, Iowa, May 2000.
46. Garber, N. J. and Patel, S. T. Effectiveness of Changeable Message Signs in Controlling Vehicles Speeds in Work Zones Report No. VTRC 95-R4. Virginia Transportation Research Council, Charlottesville, Virginia, 1994.
47. Zech, W. C. and Mohan, S. B. Evaluation of Messages on Changeable Message Signs as a Speed Control Measure in Highway Work Zones. *Practical periodical on Structural Design and Construction* 13(1), ASCE, pp.11-18, 2008.
48. Li, Y., & Bai, Y. Determining the optimal deployment location of portable changeable message signs in the upstream of work zones, 2011.
49. Benekohal, R., Wang, M., Chitturi, M., Hajbabaie, A., and Medina, J. *Speed Photo-Radar Enforcement and Its Effects on Speeds in Work Zones*, 2008.
50. Salmon, P. M., Regan, M. A., Johnston, I. *Human error and road transport: Phase one- a framework for an error tolerant road transport system*. Monash University Accident Research Centre, 2005.
51. Spainhour, L. K., Brill, D., Sobanjo, J. O., Wekezer, J., and Mtenga, P. V. *Evaluation of Traffic Crash Fatality Causes and Effects*. Florida A&M University-Florida State University. Tallahassee, Florida, 2005.
52. Hong Young, H, Ozturk, O., Ozbay, K., and Xie, K. *Work Zone Safety Analysis and Modeling: A State-of-the-Art Review*. Transportation Research Board, Washington D.C., January 2014.
53. Silverstein, C., Schorr, J., and Hamdar, S. H. *Work zones versus nonwork zones: Risk factors leading to rear-end and sideswipe collisions*. Transportation Research Board, Washington D.C., 2014.

54. Hilde E. D and Mason D. D. Effectiveness of countermeasures to reduce vehicle speeds in freeway work zones. Canadian Journal of Civil Engineering, Vol. 41, 2014

## **CHAPTER 2. ANALYSIS OF CRASHES AND NEAR-CRASHES IN WORK ZONES USING SHRP 2 NATURALISTIC DRIVING STUDY DATA**

Modified from a paper to be submitted to the Accident Analysis and Prevention  
Hossein Naraghi and Omar Smadi

### **Abstract**

The presence of a work zone increases disturbance to traffic flow and produce high cognitive workloads for drivers which can increase the safety risks. There was an increase of about 11% in work zone-related fatalities from 2010 to 2014 despite a small decrease in non-work zone-related fatalities in the U.S. (1). Work zone safety is a major concern for construction workers, travelling publics, and transportation safety professionals. Work zone impacts on safety create a strong need to protect road users and construction workers.

It is mainly believed that distraction, speeding, and other unsafe driver behaviors are the main contributing factors to work zone crashes. The available crash data is limited to reported crashes and the level of detail provided is dependent on the interpretation of the attending officer at the scene. As a result, it is not clear what behaviors drivers were involved in prior to the incident and not clear if coded work zone crashes were actually work zone-related. The Naturalistic Driving Study Data conducted by Strategic Highway Research Program (SHRP) 2 offers a unique opportunity to observe actual driver behavior. Also, using forward roadway views, work zone-related events can be coded more accurately.

The research objective is a better understanding of the role of driver behavior such as speed and distractions in work zone crashes or near-crashes (safety critical events). Work zone data were extracted from the Insight data access website. Data for a total of 256 safety critical events and 420 baseline events were requested. Data were reduced and coded using event detail table, time series data, and roadway forward videos.

Descriptive statistic and predictive modeling were used to analyze work zone safety critical and baseline events. The descriptive statistical results indicated rear-end has a high proportion in safety critical events. For work zone configuration, lane shifts with no shoulders had a much higher proportion for baseline events, while right lane closures contributed to a higher proportion of safety critical events. Safety critical events were more likely to involve female drivers, speeding, distractions, speed variations, urban area, and intersection compared to baseline events.

## 2.1 Introduction

Addressing work zone safety problems has become a high priority issue for transportation officials. A thorough knowledge of nature and potential contributing factors associated with work zone crashes is needed to make informed decisions on applying appropriate measures to improve safety concerns in work zones. This research focused on the naturalistic driving study data (NDS) conducted by The Strategic Highway Research Program (SHRP) 2. The primary objective of this study is to investigate the characteristics of crashes and near-crashes (safety critical events) and compare that to the normal driving situation (baseline events) in work zones. This chapter intends to analyze crashes and near crashes and compare that to normal driving behavior in work zones using SHRP 2 NDS data.

Several research studies indicate driver error as the main contributing factor to work zone crashes (2-5). The previous research on work zone crash causation indicated speeding, inattentive driving, speed too fast for the condition, and following too closely were the most frequent driver errors associated with severe work zone crashes. Research on driver characteristics and behaviors found age, gender, and risky driving behavior such as speeding and aggressive driving are all contributing factors to highway work zone crashes. Rumar et



al. study quantified the proportion of human factors as the major contributing factor to more than 93% of all crashes on roadways (Rumar et al. 1985, NHTSA 2015).

As literature revealed, many prior studies identified human factor as the main contributing factor in roadway crashes. Although driver behavior has contributed significantly to crashes, it is the least understood factor attributed to crash causation. This is mainly due to limited information about driver behavior in our traditional crash data. Also we have many unreported and under-reported crashes which create a huge limitation on our existing crash database. The crash data lack accurate and complete information on human factors. The driver involved in a crash might not remember what he was doing prior to the crash, be purposely hiding the facts, or might be dead in a fatal crash situation. It is therefore extremely difficult to acquire reliable and accurate driver behavior from the crash report. Another major situation arises when a risky driver behavior is not recorded in crash database because it didn't end up in any crash and was just a near-crash. A near crash was defined as a safety critical event requiring abrupt evasive behavior to avoid a crash (VTTI 2015). The near-crash can provide valuable driver behavior information in a proactive approach of crash avoidance. Prior research on driver behavior comes from analysis of traditional crash data. Although crash data is one of the most important sources for the traffic safety research, it lacks the complete and accurate driver behavior information.

This research focused on the analysis of work zone crashes and near-crashes which is collectively defined as Safety Critical Events utilizing SHRP 2 NDS data. The majority of the prior research relied on traditional crash data collected by the officers at the crash site, which often lacked human contributing factors, as what driver was doing prior to the crash. The NDS data provided a number of important driver behavior variables which helped to

account for driver behaviors associated with safety critical events and identify contributing factors to safety critical events from observed behaviors.

### **2.1.1 Background on SHRP 2 Naturalistic Driving Study**

The SHRP 2 NDS is the largest and most comprehensive driving-based research study ever conducted. NDS is designed to observe driver's daily driving behavior in a natural setting environment with no experimental control. The Virginia Tech Transportation Institute (VTTI) led this project implementation and coordination. More than 3,100 female and male drivers aged 16 to 98 were recruited in six unique and geographically distributed sites (New York, Florida, Washington, North Carolina, Indiana, and Pennsylvania). The participants, vehicle were equipped with Data Acquisition System (DAS) which consists of sensors, cameras, Geographic Positioning System (GPS), vehicle network, lane tracking system, accelerometers, eye-tracking system, and data storage. The sensors of DAS collected data such as speed, GPS, and acceleration while four cameras collected forward, rear, driver face, and over the shoulder videos. Over 3,100 drivers had over 5 million trips over the study period of more than two years, resulting in over 30 million data miles and 4 million gigabytes of data. NDS collected a variety of variables regarding driver's daily driving behavior without any experimental control. Most of the variables were collected at high frequency (10 HZ), which is every 0.1 second (6).

### **2.1.2 Background on SHRP 2 Roadway Information Database**

The Roadway Information Database (RID) was conducted to collect roadway information data for the roads driven by drivers in SHRP 2 NDS. The Center for Transportation Research and Education (CTRE) at Iowa State University led the implementation and coordination of the project, which used mobile data collection vans to

collect about 12,500 center line miles of roadway data elements in the six NDS sites. In addition, other existing roadway data from government, public and private sources, as well as supplemental data, were utilized to populate a roadway element dataset linkable to NDS trips to support a comprehensive safety assessment of driver behavior. The identified roadway data elements included information on roadway alignment, number of lanes, lane type and width, intersection types and location, lighting, signage, median type, barriers, rumble strips, and other features. The RID integrated 511 data provided by states with roadway data collected throughout NDS study locations. The integrated 511 data was the primary source of identifying work zone locations and duration (7).

## **2.2 Literature Review**

A lot of effort has been made in past few decades to address safety issues in work zones. Previous research has addressed driver, environment, and roadway/work zone characteristics which have contributed to work zone crashes. The objective of this literature review is to characterize the nature of work zone crashes and review the characteristics, types, locations, and contributing factors associated with work zone crashes identified in the previous research.

### **2.2.1 Work Zone Crash Characteristics**

Several studies were undertaken to investigate the safety of roadway work zones compared to non-work zone locations and concluded crash rates at work zones are significantly higher than non-work zone locations (9-14).

Rouphail et al. (1988) compared before and after construction crash rates on freeway work zones in Illinois. The crash rate during the construction period was found to be

increased by an average of 88% compared to the before period. The crash rate was decreased by an average of 34% for the after period compared to the construction period (9).

Garber and Woo (1990) study found a 57% and a 168% crash increase on multi-lane and two-lane highway work zones compared to non-work zone period in Virginia respectively (12).

A more recent research by Silverstein et al. (2015) used a binary probit model to compare work zone and non-work zone crashes. The study results indicated both rear-end and sideswipe collision are more probable cause of fatalities in work zones compared to non-work zones. The study also concluded clear conditions, daylight, and straight roadway segments increased the possibilities of those crashes (37).

Mixed results have been found on the severity of crashes in work zone compared to non-work zone conditions. There were studies which concluded that crashes in work zones end up to be relatively less severe than non-work zone crashes (9-10, 15) and other studies that concluded that work zone crashes were more severe compared to non-work zone crashes (13-14). Additionally, there were studies which found no significant difference between work zone and non-work zone crashes (11-12).

Akepati (2010) investigated work zone crash data for the Smart Work Zone Deployment Initiative (SWZDI) region (Iowa, Kansas, Missouri, Nebraska, and Wisconsin) to determine characteristics and contributing factors of those crashes. About 75% of crashes occurred during daylight, 69% with no adverse weather conditions. A majority of crashes occurred on a dry road surface (84%). Crash statistics showed 27.2% are injury crashes and 296 people died as a result of those crashes during the five-year period studied.

Crashes with other moving vehicles was about 73%, of which 43% and 15% were rear-end collisions and angle collisions, respectively (16).

Regression models predicted the expected number of crashes at rural two-lane highway work zones looking at crashes on upstream and inside the work zone separately (Venugopal and Tarko, 2000). The models indicated the type, duration, length, and volume of the work zone were significant factors in predicting the number of crashes in work zones. The study results revealed shorter work zones have a higher number of upstream crashes compared to longer work zones (17).

Li and Bai (2006) studied Kansas work zone crashes from 1992 to 2004, to compare fatal and injury crash characteristics. The results of this study showed head-on was the main collision type for fatal crashes, and rear-end was the major crash type for injury crashes.

Male drivers were involved in 75% of fatal crashes and 66% of injury crashes in Kansas. Drivers between 35 and 44 years old, and older than 65, are the high-risk driver groups in work zones. Male drivers aged 25 to 64 were involved in 64% of all work zone crashes, which might be due to the fact that this age group tends to drive more so they have higher exposure to the work zones (18).

A study by Li et al. (2012) on truck-related crashes in Kansas highway work zones indicated that trucks were involved in a high percentage of fatal crashes while passenger cars were mainly involved in injury crashes. About half of truck drivers were at fault in work zone fatal crashes. The maneuver before the crash for most of the truck drivers was straight following. The rear-end crash was the dominant type of crash for all severity types (19).

Research was conducted by Ulman et al. (2006) to identify the effects of night work activity on work zone crashes in Texas. They investigated the change in crash likelihood for

active and inactive night and day construction work. Results showed higher crashes for active work zones for both night and day-time than inactive work zone periods. There was a higher percentage of rear-end crashes at night-time active work zones (20).

Arditi et al. (2007) investigated crash characteristics of highway work zones by comparing daytime and nighttime construction activities. They studied fatal crashes to identify if there was any difference between night time and daytime construction. The lighting and weather conditions were included in the study as control parameters to determine their effects on the frequency of fatal crashes in work zones. The Kruskal-Wallis test was conducted to find if the number of fatal crashes and the number of people and workers involved in construction zones crashes significantly differ from nighttime to daytime conditions. This study concluded nighttime construction was more dangerous than daytime construction; however, weather condition variables had limited effects on this result (21).

### **2.2.2 Work Zone Crash Types**

A number of research projects have examined crash data to identify crash types in work zones. The rear-end crash has been identified to be the most predominant work zone crash type for all crashes by the majority of previous studies (9, 11-12, 14).

Rouphail et al. (1988) found rear-end crashes were increased by 50% during the roadway construction period. Hall and Lorenz research demonstrated rear-end crash percentage increased from 9% to 14% for the construction period (9).

Garber and Zhao (2002) concluded rear-end and sideswipe crashes are the most frequent crash types at the advanced and transition areas of work zones while fixed object and angular crashes are more dominant at the work area and termination area (13).

Rear-end work zone crashes in Singapore was assessed by Meng and Weng (2010), which found rear-end crash risks increases with lane traffic flow rate and heavy truck proportion. The study also revealed higher rear-end crash risks for work zones with lane closures and suggested early merge as an effective method to reduce rear-end crash risk at merging point (22).

A study by Daniel et al. (2000) identified head-on, angle, and single vehicle as the predominant types of fatal crashes in work zones (23).

Most fatal crashes are multi-vehicle crashes. Head-on, angle-side impact, and rear-end are the three most frequent collision types for the multi-vehicle crashes (12, 18).

Li and Bai (2008) compared characteristics of fatal and injury crashes in work zones in Kansas. The study revealed head-on collision as the dominant type of fatal crashes while rear-end was the major crash type for injury crashes (24).

Garber and Woo (1990) concluded work zone crashes were more likely to involve multiple vehicles than non-work zone crashes (12).

### **2.2.3 Work Zone Crash Locations**

A work zone consists of advanced warning area, transition area, buffer area, activity area, and termination area. There are a number of research projects which evaluated the distribution of crashes within these areas.

Activity area is the predominant location for all types of work zone crashes (13-14, 25-26). However other research concluded differently. Nemeth and Migletz (10) study found higher crashes occurred in buffer area. Srinivasan et al. (2008) revealed higher crash proportion in advanced warning area (27).

Garber and Zhao (2002) concluded rear-end crashes are the predominant crashes within the work zone advance warning area, transition area, and activity area. However, angle crashes are significantly higher at the termination area (13).

Chambless et al. (2002) studied typical characteristics of work zone crashes in Alabama, Michigan, and Tennessee and revealed that 63% of work zone crashes take place on interstate, US, and state highways, as compared to 37% of non-work zone crashes. The work zone crashes on 45 mph and 55 mph speed zones are 48% as compared to 34% of non-work zone crashes, (28).

Some studies also revealed most work zone crashes occur on rural interstate and state highways (14, 29). However, another study revealed contradictory findings. The Garber and Zhao (13) study revealed that urban highways have a higher proportion of work zone crashes compared to rural highways. Jin et al. (2008) study found no relationship between road functional class and crash distribution in work zones (30). The majority of fatal and injury work zone crashes occurred within 51-60 mph speed limit zones (18).

#### **2.2.4 Work Zone Crash Contributing Factors**

Many studies have been conducted to analyze work zone crash characteristics and their contributing factors. The findings of these studies indicate work zone crashes in different spatial locations share some common features and contributing factors.

Li and Bai (2006) concluded inattentive driving, misjudgment, and disregarding traffic control are the top contributing factors for work zone fatal crashes (18).

Chambless et al. (2002) study revealed 27% of work zone crashes were due to misjudging stopping distance and following too close in Alabama, Michigan, and Tennessee as compared to 15% for non-work zone crashes (28).



Lindly et al. (2002) similarly identified misjudging stopping sight distance and following too closely are the predominant causes of work zone crashes in Alabama according to 1994-1998 crash data. The study also found the ratio of drivers speeding in work zones were higher than non-work zone drivers (29). The results of some studies indicated following too close as the dominant contributing factor in work zone crashes (11, 14).

Kumar et al. (2015) utilized a qualitative approach by interviewing 66 construction workers from several work zones in Queensland, Australia, to identify nature and contributing factors in work zone crashes. The survey results reveal excessive vehicle speed, driver aggression towards road workers, and driver distraction are the major contributing factors to work zone crashes (31).

Li and Bai (2006) revealed driver inattention is the major cause for both fatal and injury crashes in work zones (18).

A number of studies identified speed as a major contributing factor to work zone crashes (13, 32-34). Allpress et al. (2010) study found excessive speed as a major contributing factor for increasing driver's risk of crash involvement at work zones in New Zealand (32). Sommers and McAvoy (2013) research revealed speed variance and congestion are typical causes of rear-end crashes in work zones (34).

Bryden et al (1998) study showed impact with work zone traffic control devices caused about 33% of all work zone crashes (35).

### **2.2.5 Temporal and Environmental characteristics**

Environmental factors such as lighting, weather, and surface conditions can all be contributing factors to unsafe driver behavior in work zones.

Work zone crash data for Smart Work Zone Deployment Initiative (SWZDI) was investigated by Akepati (2010) and revealed 75% of crashes occurred during daylight, and a majority of crashes (84%) occurred on a dry road surface (16). Two other earlier studies found work zone crashes were increased at night due to the higher possibility of lane closure at night (15 and 20).

A study by Arditi et al. (2007) used Kruskal-Wallis test was conducted to find if the number of fatal crashes and the number of people and workers involved in construction zones crashes significantly differ in nighttime in compare to daytime conditions. This study concluded nighttime construction is more dangerous than daytime construction; however, weather condition variables have a limited effect on this result (21). In contrast, Dissanayake and Akepati (2009) found daylight and good weather are the most probable conditions for work zone crashes (36).

The daytime off-peak hours (10:00 a.m. – 4:00 p.m.) are the most hazardous time period in work zones (18 and 31).

In another study by Hall and Lorenz (1989) inclement weather conditions and bad roadway surface were found to have a significant impact on road work crashes (11).

### **2.2.6 Driver Characteristics**

Past research indicated driver error as the main contributing factor to work zone crashes. The previous research on work zone crash causation indicate that speeding, inattentive driving, speed too fast for the condition, and following too closely were the most frequent driver errors associated with severe work zone crashes. Research on driver characteristics and behaviors found age, gender, and risky driving behavior such as speeding and aggressive driving are all contributing factors to highway work zone crashes. A number

of research quantified the proportion of human factors as the major contributing factor to more than 93% of all crashes on roadways (2-5).

Rumar et al. research (1985) studied crash causation and showed the proportion of drivers, roadway, and vehicles that were major contributing factors of crashes through the well-known Venn diagram as shown in Figure 2.1.

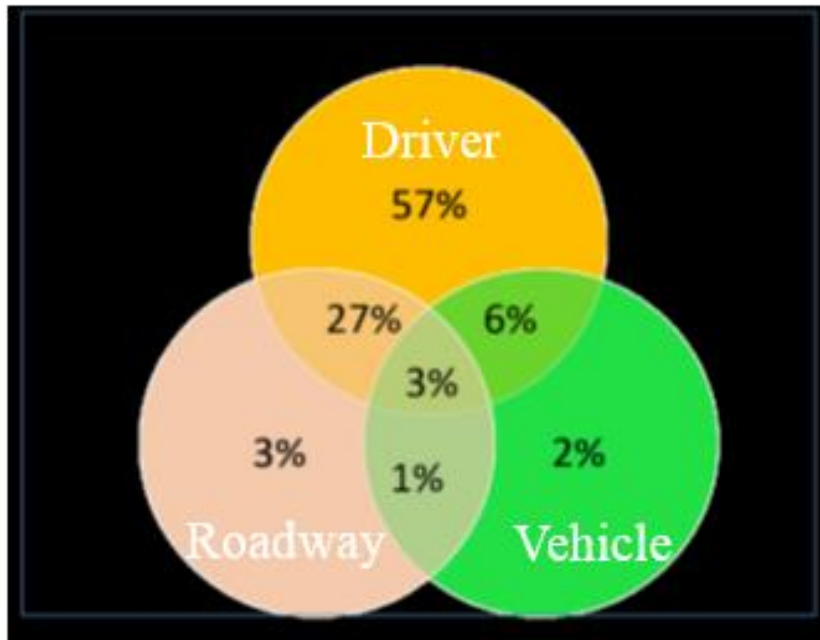

**Figure 2.1 Proportion of crash causation (Rumar et al., 1985)**

As mentioned earlier, the study found human or driver error as contributing factor to 93% of crashes, while roadway and vehicle factors with 34 and 12%, respectively have much lower proportion of crash causation.

The proportions of crash causation mainly attributed to drivers as-studied by Rumar et al., were confirmed more recently by the NHTSA study of 2015. This study was based on the National Motor Vehicle Crash Causation Survey (3). Table 2.1 shows the result of critical reasons attributed to drivers, vehicle, and environment.

**Table 2.1 Crash critical reasons attributed to driver, vehicle, and environment**

Critical Reason Attributed to	Estimated	
	Number	Percentage
Driver	2,046,000	94%
Vehicle	44,000	2%
Environment	52,000	2%
Unknown	47,000	2%
<b>Total</b>	<b>2,189,000</b>	<b>100%</b>

As shown in the table, 94% of related critical reason for crashes were attributed to drivers. Vehicle and environment each attributed only 2% to crash causation.

A number of prior research studies identified human factor as the main contributing factor in roadway crashes. Although driver behavior has contributed significantly to crashes, it is the least understood factor. This is mainly due to limited information about driver behavior in our traditional crash data. Also we have many unreported and under-reported crashes which creates a significant limitation on our existing crash database.

### 2.2.7 Summary of Findings

A number of different research revealed contradicting results for the same work zone characteristics studied. Some studies revealed work zone crashes were more severe than non-work zone crashes, while others found work zone crashes to be less severe. There were also studies which didn't find any significant difference between work zone and non-work zone crashes. There were mixed results about the work zone crashes at night versus daytime. Some studies concluded construction was more dangerous at night compared to daytime, while other studies believed daytime and good weather conditions were most probable condition for work zone crashes.

There were also some disagreement on the most predominant location of work zone crashes. As some believed advance area as the predominant locations of work zone crashes while others found higher crashes occurred in activity area. Although a study found the buffer area as the most probable location of work zone crashes.

However, there was strong agreement among many studies that found rear-end as the most predominant type of crash in work zones. Studies also found head-on was the major collision type of fatal crashes, while rear-end was the main crash type for injury crashes in work zones. Trucks were involved in more fatal crashes and passenger cars were involved more injury crashes in work zones.

A number of studies concluded speeding, inattentive driving, following too closely, and misjudging stopping distance are among the major contributing factors to work zone crashes. Also speed variance and congestion were attributed to rear-end crashes in work zones.

The majority of the previous research about work zone safety focused mainly on the descriptive statistics of crash data to examine the characteristics and to identify contributing factors to those crashes (8). Limited research has been conducted to develop specific models to link work zone crash characteristics and contributing factors. Models “partially” studied the effects of roadway, vehicle, driver, environment, and work zone configurations on work zone crash severities (8).

There are a large number of factors contributing to work zone crashes but it is mainly believed that the major contributing factors are speeding, inattentive driving, and other unsafe driver behaviors, such as following too closely. Although driver behaviors have significantly contributed to the crash causation, it is the least understood factor. This is

mainly due to limited information about driver behavior in our traditional crash data. Most driver behavior information relies on a driver's own statement or witness testimony, which could be inaccurate for various reasons. This indicates drivers' contributing factors to crashes are not very well understood.

The NDS data, which is a naturalistic observation of driving behavior, provide a unique opportunity to observe and model actual driver behavior and understand how they interact with roadway, vehicle, and traffic environment. The NDS can be utilized to develop models about driver's daily normal driving behavior in order to understand some underlying causes of crashes and to identify how drivers negotiate work zones.

### **2.3 Data Collection and Reduction**

The main data source to acquire safety critical and baseline events for work zones was the SHRP 2 InSight website (<https://insight.shrp2nds.us/home/index>). The website provide researchers with the SHRP 2 NDS data. There are different groups of variables that can be accessed through the website. Drivers, events, trips, and vehicles are the four different categories of data collected. Driver data includes age, gender, licensing age, prior traffic violation(s), annual miles driven, and driver behavior surveys. The event table provides NDS data at event levels such as crash, near-crash, and baseline. Trip information comprised average trip length, mean speed, acceleration, and so on. The vehicle data summarized vehicle information such as vehicle type, make, size, and age. The forward video for each event was available and accessible from the InSight website for researchers who obtained an Institutional Review Board (IRB) certificate.

Due to the participation of human subjects in SHRP 2 NDS data, it is required by federal regulations (Title 45 CFR, part 46.102.f) to obtain IRB approval by completing the

National Institute of Health (NIH) web-based training course prior to the implementation of the research. The analysis of data in this research complied with the data usage agreement that has been submitted to IRB and VTTI. The IRB approval is provided in Appendix A.

Forward roadway views along with a set of criteria were used to determine if the coded events were actually work zone-related. Lane closure and the presence of construction equipment and workers were the most important criteria used to validate work zone-related events. The safety critical events were reduced to 148, which was further refined to 110 events by selecting multi-lane urban and rural highways. Multi-lane urban and rural had the highest proportion among all work zone roadway classifications.

A total 1171 baseline work zone-related events were initially identified from the InSight website. A total of 443 events were requested from VTTI and 420 baseline events were received. The baseline data were reduced to multi-lane urban and rural highway to be identical to roadway classifications selected for safety critical events. Finally, 89 baseline events were manually coded as work zone-related utilizing forward roadway view videos. The reduced baseline events were on active work zones. About 35 variables were extracted and coded from forward roadway views and time series data.

### **2.3.1 SHRP 2 Study Sample Proportion**

The study data sample was investigated to confirm if it is representative of that for the NDS study. Figure 2.2 shows the proportion of drivers by age group and gender for the NDS study as compared to our study sample.

Young (16-24) and middle (25-64) age female drivers are about the same proportion in both the NDS and the study sample. It is also the same scenario for male drivers as both young and middle aged drivers are about 45% in both samples.

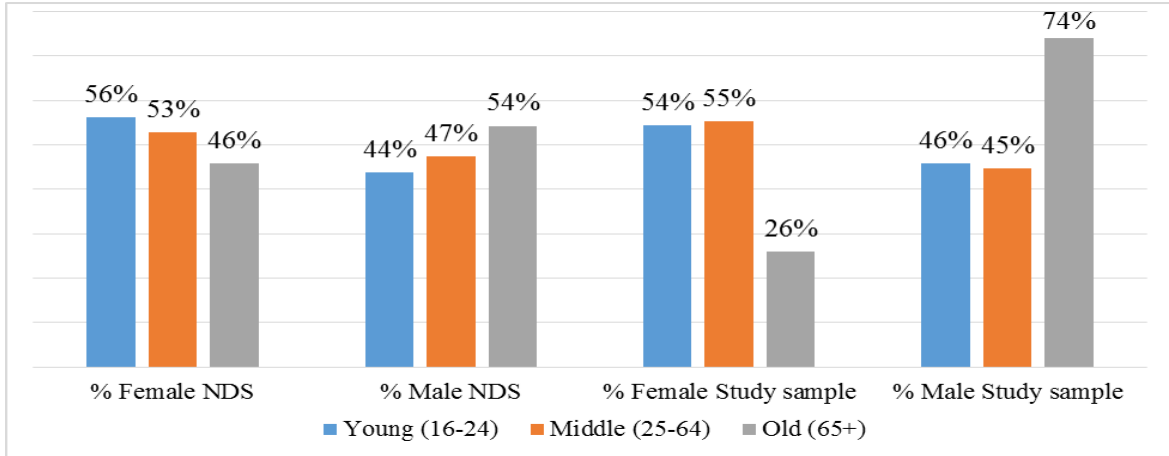

**Figure 2.2 Proportion of drivers by age group & gender for NDS and study sample**

The only difference is in old drivers as the proportion of older (65+) female drivers for the NDS is 46% compared to 26% for the study sample. The case is reversed for older male drivers, as the proportion of them in the study sample is higher with 74% as compared to 54% for the NDS study.

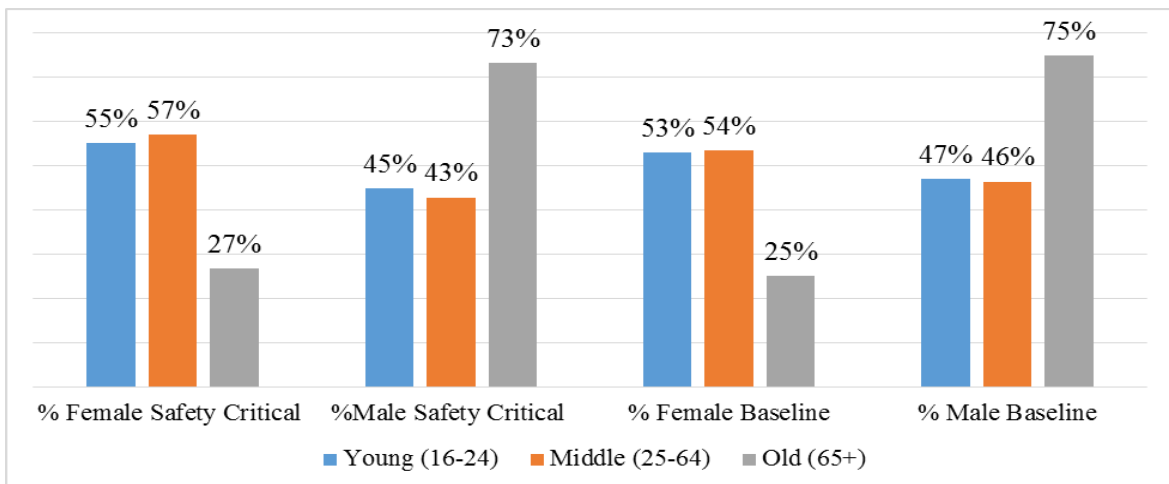

**Figure 2.3 Proportion of drivers by age group and gender for safety critical and baseline events samples**

The proportion difference between safety critical events and baseline events in the study sample has been investigated. Figure 2.3 reveals the proportion of drivers involved in



safety critical and baseline events by age group and gender. The data in the graph clearly indicates that the proportion of both female and male drivers involved in safety critical and baseline events are quite identical among all age groups.

## **2.4 Methodology**

Initially a descriptive statistical analysis was conducted to study the distribution of work zone safety critical and baseline events over numerous variables. The main factors for each variable which were responsible for the high proportion of safety critical events were identified to determine major driving behaviors that contributed to the occurrence of the safety critical situations.

Secondly, to identify the influence of the major contributing factors to the occurrence of the event, predictive models were produced to define the relationship between explanatory variables and the outcome of the event. Logistic regression was implemented to produce models which predicted the probability of safety critical event occurrences at work zones by major contributing factors. The multiple regression analysis was used to predict the event type outcome by using nominal or continuous explanatory variables.

### **2.4.1 Descriptive Statistical Analysis Results**

Descriptive statistics have been utilized to analyze NDS data in work zones. It was necessary to identify the characteristics of the safety critical events that drivers were involved in and then determine the factors that contributed to the occurrence of safety critical situations as compared to normal work zone driving (baseline).

### 2.4.1.1 Safety Critical Events Characteristics

Safety critical events are the events that are coded as crash or near-crash in the NDS SHARP 2 database. The distribution of safety critical events is shown in Figure 2.4.

An analysis of the data reveals subject drivers were involved in 62% rear-end event and 2% were rear-ended from back. Sideswipe with 25% was the second highest safety critical event type followed by conflict with construction equipment and road departure 5% each. The angle crash or near-crash is 2% of all safety critical events.

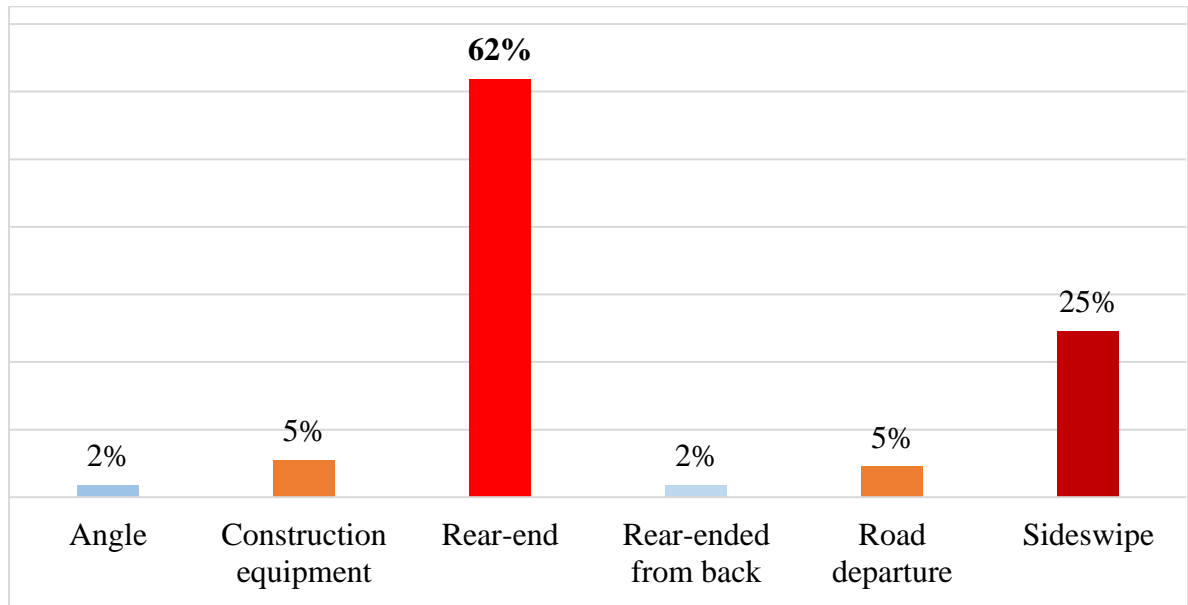

**Figure 2.4 Safety Critical Events Distribution**

The results here are mostly in line with literature findings, which show rear-end as a predominant crash type in work zones. Rear-end events were further studied to find the predominant factors in driving maneuvers, intersection influence, and work zone status which were associated to those events. On the driving maneuvers, going straight with 81%, merging 10%, and changing lanes 7% were the predominant factors. The presence of equipment with 66% and the presence of equipment and workers with 19% were the main

work zone statuses associated with rear-end events. Interchanges at 20% and intersection at 17% had influence on the occurrence of rear-end events.

#### 2.4.1.2 Contributing Factors to Safety Critical Events

The study looked at driver, environmental, roadway, and vehicle factors that contribute to work zone crashes and near crashes. Figure 2.5 and 2.6 illustrates the age and gender distribution of the drivers involved in safety critical events and baseline conditions.

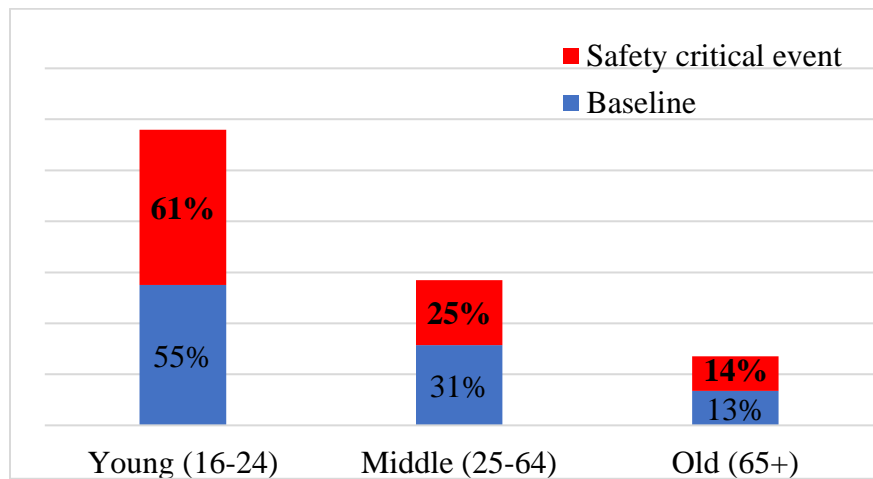
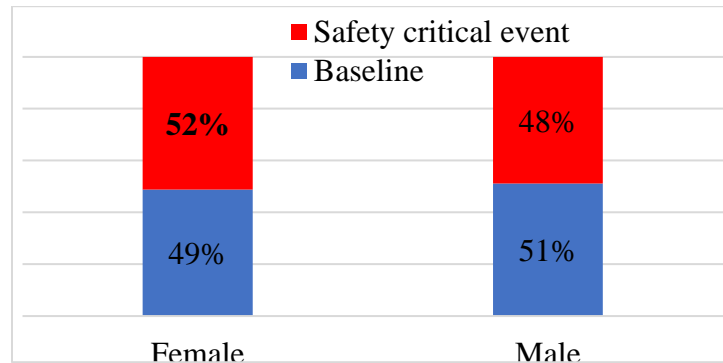

**Figure 2.5 Event type by age group**

Drivers were divided into three age groups: Young aged (16-24), middle aged (25-64), and old aged (65 and older). The young aged drivers had the highest percentage at 61% and 55% for safety critical and baseline events, respectively. The middle aged drivers were involved in 25% of safety critical events and 31% of baseline events. The older drivers' proportion was about 14% for both safety critical and baseline events.

Female drivers' involvement in safety critical events was more than 8% higher than that for male drivers (52% and 48% for female and male drivers respectively). Young drivers' involvement in safety critical events was 12% higher compared to baseline for the same age group, while middle age drivers' involvement in safety critical events was 24%

lower compared to baseline for that age group. The age distribution of our sample was very similar to that for all work zone-related drivers.



**Figure 2.6 Event type by driver gender**

Figure 2.7 shows driving maneuver prior to incidents. About 16% more drivers were going straight prior to the baseline events compared to safety critical events (87% compared to 74%). Changing lane and merging were twice as high for safety critical as compared to baseline events. Other maneuvers, including passing, turning, and negotiating curves, were also more than two times higher for safety critical events compared to the baseline.

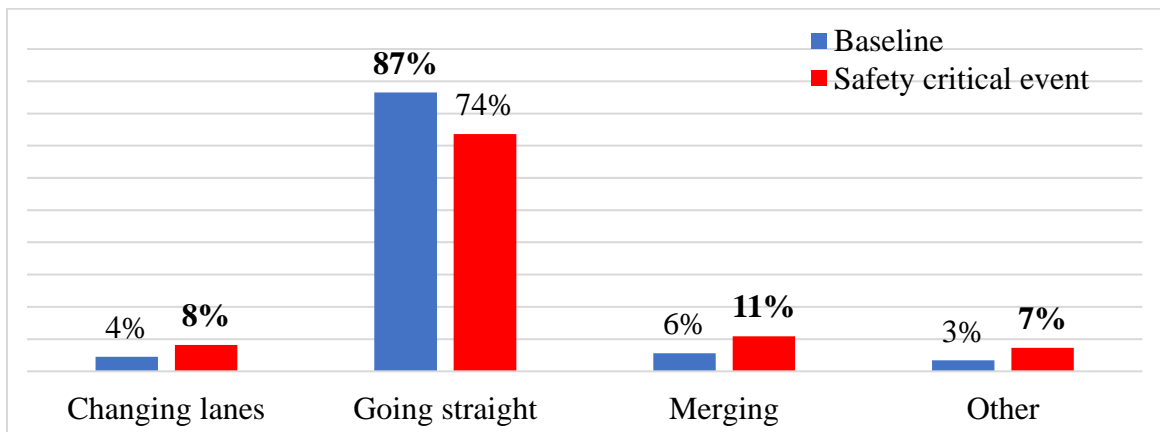

**Figure 2.7 Driving maneuver prior to the event**

Driver behavior and contributing factors are shown in Figure 2.8 for the safety critical situations and normal work zone driving. Speeding is a major contributing factor to safety

critical events at 23% which is about three times higher than that for baseline at 7%. As can be seen from the chart, distractions with 22% and cell phone distraction with 15% are very important contributing factors to safety critical events.

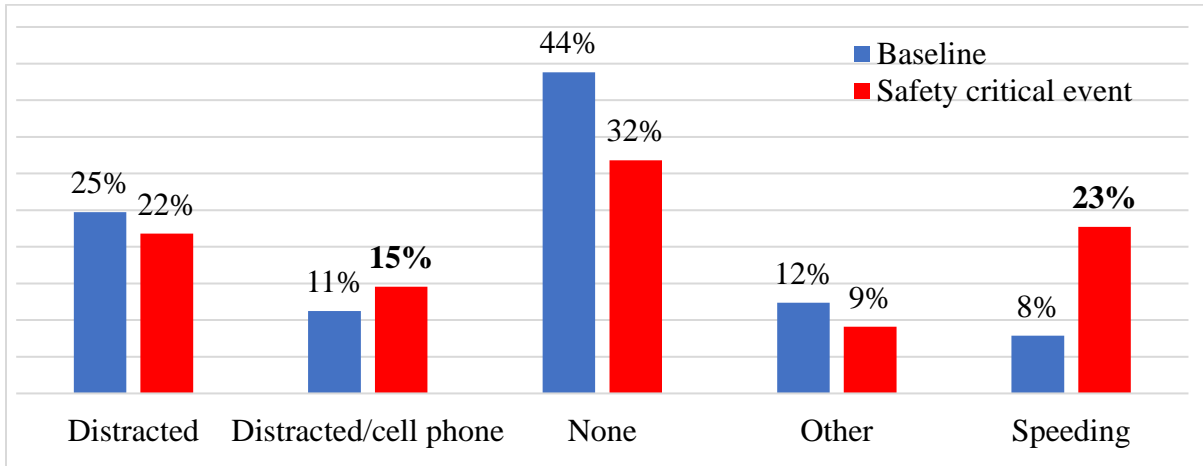
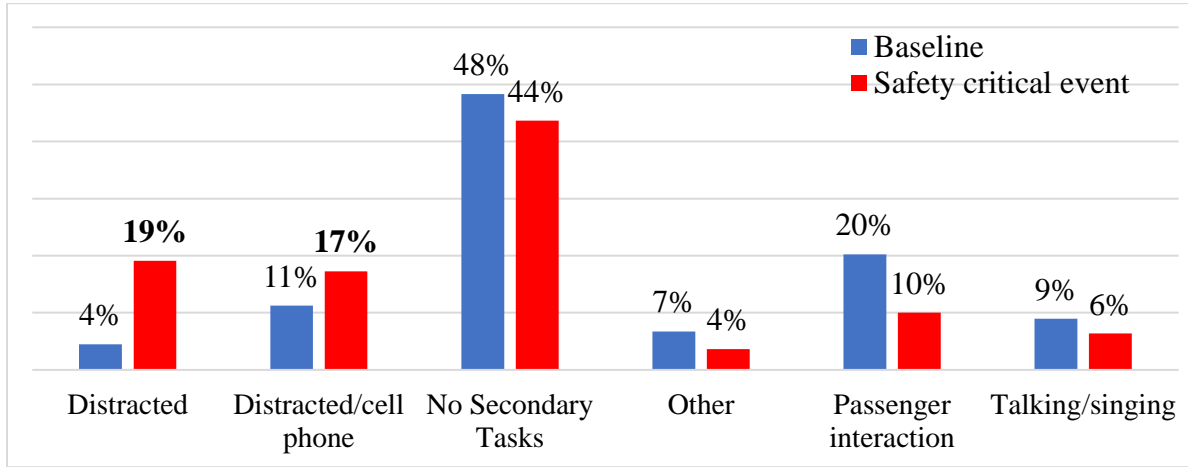

**Figure 2.8 Diver behavior and contributing factors by event type**

Distractions for baseline were derived from secondary tasks as the driver behaviors for baseline events were not populated appropriately. The distracted percentage for baseline is relatively high as it includes interaction with passengers, talking, and singing, which were considered as distraction based on the variable description in the Insight SHARP 2 database.

The factors which are considered secondary tasks to driving are presented in Figure 2.9. The secondary task data is complementary to driving behaviors which will help us to identify what drivers were actually doing that contributed to safety critical event involvement. The secondary task data indicate 56% of drivers engaged in secondary tasks in safety critical events. Again secondary task data clearly reveals distraction as a major contributing factor to safety critical events at 36% which consists of 17% of cell phone distraction. The distractions that contributed to safety critical events are more than four times

than that in baseline events. Interaction with passenger is 20% for baseline which was twice as high as that for safety critical events.



**Figure 2.9 Secondary task distribution by event type**

The distribution of lane closure by type and location are shown in Figure 2.10. The most important finding of this analysis is lane shift with no shoulder represents 29% of baseline events which is more than 3 times of that in safety critical events. Right lane closure at 32% for safety critical events has a higher proportion than that for baseline events at 25%.

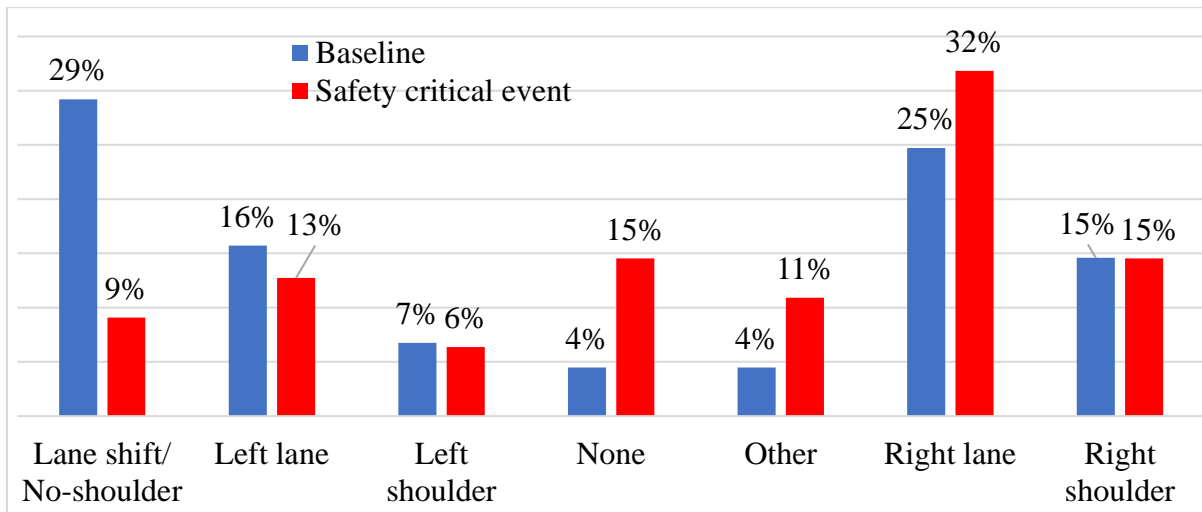

**Figure 2.10 Lane closure type and location by event type**

The percentage of shoulder closures on the right or left is pretty comparable for safety critical and baseline events. Left lane closure for baseline is relatively higher than that for safety critical events. Other lane closures consist of closures with 2 or more lanes. It is 15% for safety critical events compared to 4% for baseline, which is more than 3 times higher. The analysis results for traffic conditions in work zones are illustrated in Figure 2.11.

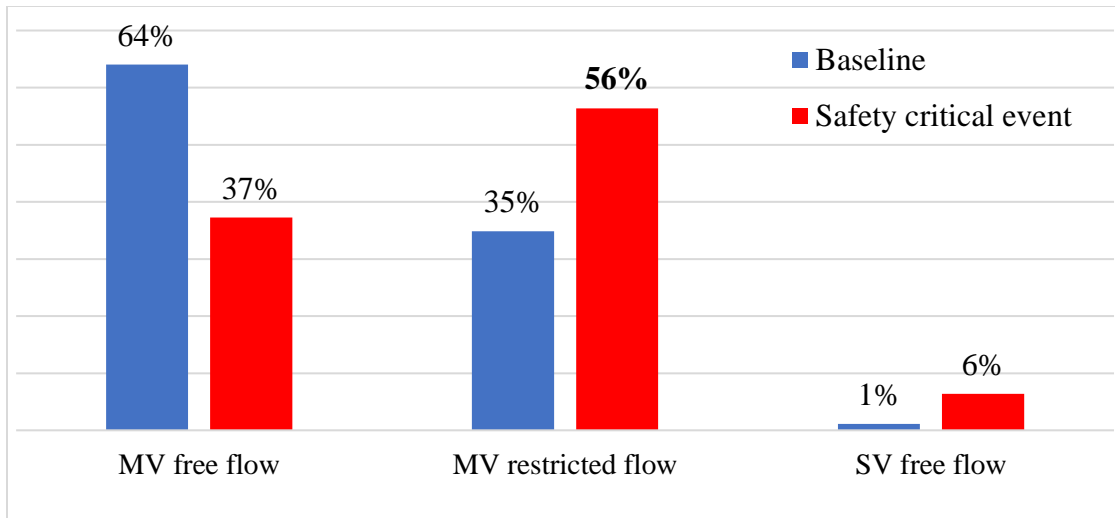

**Figure 2.11 Traffic condition in work Zones by event type**

Multi vehicle free flow proportion is 64% for baseline compared to 37% for safety critical events. In contrast, multi vehicle restricted flow is 46% higher for safety critical events compared to baseline. Single vehicle free flow is 6% for safety critical event and 1% for baseline.

Additional variables were coded and reduced to identify safety critical event causation and major contributing factors which are shown in Table 2.2. Pavement surface condition was dry 87% and 94% for safety critical events and baseline respectively. The proportion of safety critical events on wet pavement was more than two times of that for baseline.

The proportion for number of passengers for baseline was slightly higher than that for safety critical events. The effect of bad weather conditions was very small for both safety critical and baseline events.

The proportion of urban highway contributed to safety critical events was 65% compared to 30% for baseline events which explains a very high proportion of rear-end situations. Rural highway contributed to 35% and 69% of safety critical and baseline events respectively.

Straight and level roadway had higher proportion for baseline with 93% compared to 84% for safety critical events while curves with 16% was more than twice as much for safety critical events than baseline.

Intersection and interchanges had a very high influence on the occurrence of safety critical events with 42% compared to only 6% for baseline events.

Speed variation which is the network speed standard deviation was one of the major contribution factors to the safety critical events. Standard deviation greater than 4 mph and less than 26.5 mph was 90% for safety critical events while it was 14% for baseline, a huge speed variation for safety critical events. Speed limit greater than 60 mph was higher for the baseline than it was for the safety critical events.

This might be due to the fact that GPS positional information were missing for 41% and 24% for safety critical and baseline events respectively. Therefore the speed limits for those events were not obtained.



**Table 2.2 Additional variables contributing factors**

<b>Variable</b>	<b>Safety Critical Events Contributing Factors</b>	<b>Baseline Events Contributing Factors</b>
<b>Number of Passenger</b>	Zero (75%), One (22%), Two (3%), Four (1%)	Zero (65%), One (29%), Two (3%), Three (2%)
<b>Weather Condition</b>	No adverse condition (91%), Raining (5%), Mist (4%)	No adverse condition (94%), Raining (4%), Mist (2%)
<b>Pavement Condition</b>	Dry (87%), Wet (13%)	Dry (94%), Wet (6%)
<b>Lighting Condition</b>	Daylight (77%), Darkness, lighted (14%), Dusk (7%), Darkness, not lighted (2%)	Daylight (75%), Darkness, lighted (11%), Dusk (5%), Darkness, not lighted (9%)
<b>Roadway Classification</b>	2-lane urban highway (36%), 3-lane urban highway (29%), 2-lane rural highway (22%), 3-lane rural highway (13%)	2-lane rural highway (49%), 3-lane urban highway (21%), 3-lane rural highway (20%), 2-lane urban highway (9%)
<b>Roadway Geometry</b>	Straight (84%), Curve right (10%), Curve left (6%)	Straight (93%), Curve right (4%), Curve left (3%)
<b>Roadway Grade</b>	Level (83%), Grade up (10%), Grade down (6%), Hillcrest (2%)	Level (93%), Grade down (5%), Grade up (2%)
<b>Construction Activity</b>	Equipment (70%), Equipment and workers (15%), None (13%), Not visible (3%)	Equipment (71%), Equipment and workers (26%), Not visible (3%)
<b>Construction Sign present</b>	Yes (58%), No (22%), Not visible (20%)	Yes (69%), Not visible (31%)
<b>Intersection Influence</b>	No (58%), Yes (42%)	No (94%), Yes (6%)
<b>Speed Limit</b>	$\leq 40$ mph (18%), $\geq 45$ mph and $\leq 55$ mph (52%), $\geq 60$ mph (30%)	$\leq 40$ mph (3%), $\geq 45$ mph and $\leq 55$ mph (49%), $\geq 60$ mph (48%)
<b>Speed Variation (SD)</b>	$< 2$ mph (3%), $\geq 2$ mph and $< 4$ mph (7%), $\geq 4$ mph and $\leq 7.5$ mph (21%), $\geq 7.6$ mph and $\leq 26.5$ mph (69%)	$< 2$ mph (55%), $\geq 2$ mph and $< 4$ mph (31%), $\geq 4$ mph and $\leq 7.5$ mph (14%)

## 2.4.2 Logistic Regression Modeling

Logistic regression or logit model is used to model work zone event type outcome. In the logit model, the log odds of the outcome is modeled as a linear combination of predictor variables. Odds are defined as ratio of the probability of the occurrence of safety critical event versus normal work zone driving condition (baseline). The logistic regression model is expressed as follow:

$$\text{Logit (Y =1|X)} = \log (\text{odds}) = \log \left( \frac{P}{1-P} \right) = \beta_o + \beta_1 X_1 + \dots + \beta_k X_k$$

$Y$ : Odds of a safety critical event occurs

$P$ : Probability of safety critical event occurs

$\beta_o$ : Model intercept

$\beta_k$ : Regression Coefficient

$X_k$ : Explanatory variable

Maximum likelihood estimate can be used to estimate parameters combinations that maximize the probability of the observed outcome. The null hypothesis states that all coefficient of predictors are equal to zero. If the predictors have influence on the outcome result, the test result is significant at 0.1 level and the null hypothesis will be rejected. The 0.1 significance level was used to enable us to include more explanatory variables in the model which could improve overall the predictive ability of the model.

From the descriptive statistical analysis, it can be concluded that speeding and distractions are the main driver contributing behaviors to the outcome of the events. Additionally, speed variation, intersection influence, urban area work zones, and driver age and gender are the major contributing factors.

The logistic regression models produced to find the impact of predictor variables on the outcome of the event. The major explanatory variables and response variable descriptions and coding levels used in the model are shown in Table 2.3.

**Table 2.3 Variable definition and coding for the model**

Variable	Description	Level	Value
Event outcome	Event type	Baseline	0
		Safety critical event	1
Driver Behavior	Aggressive driving and Exceeding posted Speed	Not-Speeding	0
		Speeding	1
	Distraction	No-Distraction	0
		Distraction	1
Speed variation	Speed standard deviation	Continuous	
Intersection Influence	Under influence of Intersection, Interchange	No	0
		Yes	1
Urban work zones	Work zone is in urban area	Rural	0
		Urban	1
Gender	Drivers gender	Male	0
		Female	1

The model results of predictor estimation for work zone event type are presented in Table 2.4. The effect of all continuous and categorical variables was tested to develop the best model that fit the data. All variables remained in the model are significant at 90% confidence level. This model predicts the probability of the outcome of an event in the work zone with six predictors (explanatory variables).

All six explanatory variables have positive impact on the occurrence of an event outcome since the coefficient estimates are positive for all six predictors. When a driver is speeding, the probability of the occurrence of a safety critical event is higher than that when a driver is not speeding. Distraction and gender with positive coefficient are the other driver behavior which positively contributed to the outcome of an event. Work zones in urban areas

**Table 2.4 Logistic regression model parameter estimate for work zone event outcome**

<b>Parameter Estimate</b>				
<b>Variable</b>	<b>Coeff. Estimate</b>	<b>Std. Error</b>	<b>Chi Square</b>	<b>Prob. &gt; Chi Sq.</b>
Intercept	-7.437	1.382	28.95	<.0001
Speeding	2.463	0.907	7.37	0.0066
Distraction	1.186	0.639	3.44	0.0636
Speed variation	0.928	0.176	27.7	<.0001
Interchange/ Intersection influence	1.751	0.822	4.54	0.0331
Urban area	2.434	0.673	13.09	0.0003
Gender	1.227	0.682	3.24	0.0721

also have a high positive coefficient which indicates the probability of an event to be a safety critical is higher in urban area work zones compared to rural areas. Interchanges or intersections also positively affect the outcome of an event with relatively high coefficient. Speed variation is also a significant explanatory variable in determining the outcome of an event. All the explanatory variables in the model are significant at 90% confidence level.

Predicted logit model for work zone safety critical events can be expressed as:

$$= -7.437 + 2.463 * (\text{Speeding}) + 1.186 * (\text{Distraction}) + 0.928 * (\text{Speed Variation}) + 1.751 * (\text{Interchange/Intersection influence}) + 2.434 * (\text{Urban}) + 1.277 * (\text{Gender})$$

Odd ratios were developed to interpret these coefficients and to quantify the magnitude of the predictors in predicting the outcome of an event in work zones as shown in Table 2.5.

The odd ratio indicates the ratio of probability of the occurrence of safety critical events to the probability of the non-occurrence (baseline).

The ratio of speed is 11.73. It indicates that the probability of the occurrence of a safety critical event in work zones is 11.73 times higher than the probability of an occurrence of a baseline event when a driver is speeding.

**Table 2.5 Odds ratio for work zone event outcome predictors**

<b>Odds Ratio</b>			
<b>Variable</b>	<b>Odd ratio</b>	<b>5%</b>	<b>95%</b>
Speeding	11.73	2.15	80.2
Distraction	3.27	0.98	12.51
Speed variation	2.53	1.88	3.8
Interchange/Intersection influence	5.76	1.25	33.34
Urban area	11.4	3.34	48.7
Gender	3.41	0.96	14.57

The probability of the occurrence of a safety critical event is 3.27 times greater than that for the baseline if a driver is distracted. For gender variable, the probability of a safety critical event occurrence is 3.41 greater for female drivers compared to a baseline event. The probability of an occurrence of a safety critical event is 5.76 times higher than that for a baseline event at the proximity of an interchange or an intersection. The probability of being involved in a safety critical event is 2.53 times greater than that for a baseline event when speed variation is high at work zones. The speed variations were mainly due to the restricted flow at work zones due to the lane change, merging, and sudden stops.

There is a big spread between 5% and 95% confidence level which is due to the small sample size. For examples, speed variable with 35 observations is spread between 2.15 and 80.2. This means we are 95% confident that the probability of the occurrence of a safety critical event is between 2.15 and 80.2 times greater than that for a baseline event if a driver is speeding. As it can be seen from table 4, the spread 5% to 95% confidence level is much lower for speed variation because that variable includes 199 observations.

## 2.5 Summary and Conclusions

The objective of this research was to investigate the characteristics of safety critical events and compare that to the baseline events to identify the main contributing factors associated with work zone safety critical events. Previous research mainly found that the major contributing factors are speeding, inattentive driving, and following too closely. The researchers also found driver behavior significantly contributed to the crash causation and revealed human factor contributed to about 93% of crashes. Although driver behavior is the main contributing factor, it is the least understood factor attributed to crash causation.

The NDS data provide a unique opportunity to observe and model actual driver behavior and understand how they interact with roadway, vehicle, and traffic environment. The NDS data was utilized to provide insight into drivers' daily normal driving behavior in order to understand some underlying causes of crashes and to determine how drivers negotiate work zones. The NDS provided near-crash data which have never been reported in traditional crash data.

The descriptive statistics revealed a number of important findings in this research. The rear end crashes attributed to more than 67% of safety critical events. Young drivers (16-24) as well as female drivers were over-represented in safety critical events. The descriptive statistics also revealed 56% of drivers were engaged in secondary tasks before the occurrence of safety critical events. Distractions and speeding accounted for 60% of driver behaviors that contributed to safety critical events. Right lane closures contributed to the highest risk in safety critical events and lane shift with no shoulder contributed the least to the safety critical events compared to normal driving condition.

The logistic regression model was used to predict the outcome of an event based on various identified explanatory variables. The effects of all continuous and categorical variables were tested to develop the best model fitted the data. The model found 6 out of 18 tested variables to be statistically significant. All variables remained in the model are significant to a 90% confidence level. The model predicted the probability of event outcome based on six predictors. Speed, distractions, speed variations, interchange/intersection, urban area, and gender were significant and all positively correlated with the occurrence of the safety critical event in work zones. The odd ratios provide insight about the magnitude of the predictors and found speeding with a value of 11.7 as the highest contributing factor to the event outcome.

In conclusion, this research used the SHRP 2 NDS data to determine safety implications associated with crashes and near-crashes (safety critical events) in work zones. Analyzing crash data is not a new idea, but the NDS data provided researchers with important additional data about traffic conflicts, normal driving behavior, risk perception, and much more. The NDS reformed crash data strategies by providing near crash data, the information which was never reported in traditional crash reports. This study found that when speeding, the probability of getting involved in safety critical events is 11.7 times higher than baseline. The probability is 3.3 times higher when distracted. The model also revealed the probability of female drivers getting involved in a safety critical events is 3.4 times higher compared to baseline. Similarly, the probability of getting involved in safety critical events is higher in urban areas and in the vicinity of interchanges or intersections. Higher speed variations also was an important contributing factor to increase the probability of safety critical events involvement.

The findings of this research had important suggestions for transportation agencies. It is recommended to prepare a comprehensive work zone safety plan with appropriate and effective safety measures to get drivers' attention and reduce traffic speed in and about work zones. There is a need to identify the effectiveness of various safety measure devices and layouts applied in work zones to encourage drivers to slow down and safely navigate the work zone.

It is also recommended to educate and inform drivers on the risk of distractions, especially in locations such as work zones where unexpected conflicts exist and produce high cognitive workloads for drivers. The distractions risk awareness should more specifically target female drivers who were involved with a higher proportion of secondary tasks as data indicated.

### **2.5.1 Limitations**

The main limitation of this research was sample size. The small sample size of 110 safety critical events created some hurdles in building statistical inferences from the logistic regression model. Some of the variables in work zone related-data were combined for the purpose of analysis due to small sample size and diversity of categories in each variable. Small sample size is a main issue in analyzing some of the predominant factors in our data set. For example, all type of cell phone-related distractions were combined (e.g. talking, texting, browsing, dialing, holding, locating, reaching, and other). Also, the effect of texting and cell phone usage on the outcome of an event could not be verified due to the small sample size.

Baseline events were not matching comparable work zone configurations, as the baseline events were coded for only 21 seconds duration. The segment of work zones coded



could occur in any area of the work zone (upstream, work area, or downstream). Therefore, none of the baseline events include full driving trace from the upstream all the way throughout the work area and termination of the work zone.

The baseline data is limited to 89 observations including multi-lane highways only due to time and budget constraints. This may not be representative of all the SHARP 2 NDS baseline data and may affect our results.

All in all, sample size was the major limitation of this study. Due to the scarce number of the safety critical events in the NDS data, it is recommended to use crash surrogates to model the safety impacts associated with work zones. As this research found speed as the major contributing factor to the safety critical events, it can be used as a crash surrogate. The NDS data revealed speed data as the most complete collected variable to be used as a crash surrogate.

## 2.6 References

1. National Work Zone Safety Information Clearinghouse. Traffic Crashes in Work Zones. <https://www.workzonesafety.org/crash-information/workzone-fatalities/workzone-fatalitiesmotor-vehicle-traffic-crashes-2014/>. Accessed November 2016.
2. Rumar K., Evans L. & Schwing R. The Role of Perceptual and Cognitive Filters in Observed Behavior. Human Behavior in Traffic Safety, eds. Plenum Press, 1985.
3. National Highway Traffic Safety Administration, Traffic Safety Facts, Crash Statistics, February 2015. <https://crashstats.nhtsa.dot.gov/Api/Public/ViewPublication/812115>. Accessed 8/28/2017.
4. Salmon, P. M., Regan, M. A., Johnston, I. Human error and road transport: Phase one- a framework for an error tolerant road transport system. Monash University Accident Research Centre, (2005).

5. Spainhour, L. K., Brill, D., Sobanjo, J. O., Wekezer, J., and Mtenga, P. V. Evaluation of Traffic Crash Fatality Causes and Effects. Florida A&M University-Florida State University. Tallahassee, Florida, 2005.
6. Dingus, T. A., Hankey, J. M., Antin, J. F., Lee, S. E., Eichelberger, L., Stulce, K., McGraw, D., Perez, M., Stowe, L. Naturalistic Driving Study: Technical Coordination and Quality Control. Virginia Tech Transportation Institute. Blacksburg, VA, 2014.
7. Smadi, O. SHRP 2 S-04A Roadway Information Database Development and Technical Coordination and Quality Assurance of the Mobile Data Collection Project. Presented at the 7th SHRP 2 Safety Research Symposium, Washington D.C., 2012.
8. Hong Young, H, Ozturk, O., Ozbay, K., and Xie, K. Work Zone Safety Analysis and Modeling: A State-of-the-Art Review. Transportation Research Board, Washington D.C., Januray 2014.
9. Roupail, N. M., Yang, Z. S., and J. Fazio, J. Comparative Study of Short- And Long-Term Urban 23 Freeway Work Zones. Transportation Research Record 1163, pp. 4-14. Transportation Research Board, Washington, D.C., 1988.
10. Nemeth Z. A., and Migletz, D. J. Accident Characteristics Before, during, and After Safety Upgrading projects on Ohio's Rural Interstate System. Transportation Research Record 672, pp. 19-23. TRB National Research Council, Washington, D.C., 1978.
11. Hall, J. W., and Lorenz, V. M. Characteristics of Construction-Zone Accidents. Transportation Research Record 1230, pp. 20-27 TRB National Research Council, Washington D.C., 1989.
12. Garber, N. J., and Woo, T. H. Accident Characteristics at Construction and Maintenance Zones in Urban Areas. Report No. VTRC 90-R12. Virginia Transportation Research Council, 1990.
13. Garber, N. J., & Zhao M. Distribution and characteristics of crashes at different work zone locations in Virginia. Transportation Research Record, 1794, pp.19-28. Transportation Research Board, Washington, D.C., 2002.
14. Pigman, J. G., and Agent, K. R. Highway Accidents in Construction and Maintenance Work Zone. In Transportation Research Record 1270, pp. 12-21. Transportation Research Board, Washington, D.C., 1990.

15. Ha, T. and Nemeth, Z.A., Detailed Study of Accident Experience in Construction and Maintenance Zones. Transportation Research Record 1230, pp. 38-45. TRB National Research Council, Washington D.C., 1995.
16. Akepati, S. R., Characteristics and Risk Factors Associated with Work Zone Crashes. Kansas State University, Manhattan, Kansas, Master Thesis pp. 1-145, 2010.
17. Venugopal, S. and Tarko, A. Safety Models for Rural Freeway Work Zones. CD-ROM. Transportation Research Board, Washington D.C., 2000.
18. Li, Y., and Bai, Y. Fatal and Injury Crash Characteristics in Highway Work Zones. CD-ROM. Transportation Research Board of the National Academies, Washington, D.C., 2006.
19. Li, Y., Cheng, F., and Bai, Y. Characteristics of Truck-Related Crashes in Highway Work Zones. Ninth Asia Pacific Transportation Development Conference, Chongqing China, pp. 364-371, 2012.
20. Ullman, G. L., M. D. Finley, and B. R. Ullman. Analysis of Crashes at Active Night Work Zone in Texas. CD-ROM. Transportation Research Board of the National Academies, Washington, D.C., 2006.
21. Arditi, D., Lee, D. E., Polat, G. Fatal accidents in nighttime vs. daytime highway construction work zones. Journal of Safety Research 38, 399-405, 2007.
22. Meng, Q., Weng, J. Evaluation of rear-end crash risk at work zone using work zone traffic data. Accident Analysis and Prevention 43 (4), 1291-1300, 2011.
23. Daniel, J., Dixon, K., and Jared, D. Analysis of Fatal Crashes in Georgia Work Zones. Transportation Research Record: Journal of the Transportation Research Board No. 1715, pp. 40 18-23, 2000.
24. Li, Y., Bai, Y. Development of crash-severity-index models for the measurement of work zone risk levels. Accident Analysis and Prevention 40, 1724-1731, 2008.
25. Akepati, S. R. and Dissanayake, S. Characteristics and Contributory Factors of Work Zone 23 Crashes. Transportation Research Board 90th Annual Meeting, Washington, D.C., 2011.
26. Salem, O. M., Genaidy, A. M., Wei, H. and Deshpande, N. Spatial Distribution and Characteristics of Crashes at Work Zones of Interstate Freeways in Ohio. In Proceedings of the 2006 8 IEEE Intelligent Transportation Systems Conference, Toronto, Canada, pp. 1642-1647, 2006.

27. Srinivasan, S., Carrick, G., Zhu, X., Heaslip, K., and Washburn, S. Analysis of Crashes in Freeway Work Zone Queues: A Case Study. Report No: 07-UF-R-S3. Transportation Research 44 Center, University of Florida, Florida, 2008.
28. Chambless, J., Chadiali, A. M., Lindly, J. K, and McFadden, J. Multistate Work Zone Crash Characteristics. ITE Journal, Vol. 72, pp46 – 50, 2002.
29. Lindly, J., Noorjahan, S., and Hill, S. Identification of Potential Enhancements for Work Zone Safety in Alabama. UTCA Report Number 00465, University Transportation Center for Alabama, Tuscaloosa, Alabama, 2002.
30. Jin, T.G., Saito, M., and Eggett, D. L. Statistical Comparisons of the Crash Characteristics on 15 Highways between Construction Time and Non-Construction Time. Accident Analysis and Prevention 40(6), pp. 2015-2023, 2008.
31. Debnath, A. K., Blackman, R., and Haworth, N. Common hazards and their mitigating measures in work zones: A qualitative study of worker perceptions. Journal of Safety Science 72, 293–301, 2015.
32. Allpress, J.A., and Leland Jr. L.S. Reducing traffic speed within roadwork sites using obtrusive perceptual countermeasures. Accident Analysis & Prevention, Volume 42, Issue 2, pp. 377-383, 2010.
33. Raub, R.A., Sawaya, O.B., Schofer, J.L. and Ziliaskopoulos, A. Enhanced Crash Reporting to Explore Work Zone Crash Pattern. Paper No.01-0166, Transportation Research Board, Washington D.C., 2001
34. Sommers, N. M., and McAvoy, D. S. Improving Work Zone Safety through Speed Management. Ohio State University, June 2013.
35. Bryden, J. E., Andrew, L. B., and Fortuniewicz, J. S. Work Zone Traffic Accidents Involving 36 Traffic Control Devices, Safety Features, and Construction Operations. Transportation Research 37 Record: Journal of the Transportation Research Board No. 1650, pp. 71-81, 1998.
36. Dissanayake, S. and Akepati, S. R. Characteristics of Work Zone Crashes in the SWZDI 20 Region: Differences and Similarities. Mid-Continent Transportation Research Symposium, Ames, Iowa 2009.
37. Silverstein, C., Schorr, J., Hamdar, S.H. Work zones versus non-work zones: Risk factors leading to rear-end and sideswipe collisions. Transportation Research Board, Washington D.C., 2014.

### **CHAPTER 3. MULTIPLE CHANGEPOINTS DETECTION OF SPEED TIME SERIES TRACES IN WORK ZONES USING SHRP 2 NATURALISTIC DRIVING STUDY DATA**

Modified from a paper to be submitted to the Transportation Research Record  
Hossein Naraghi and Omar Smadi

#### **Abstract**

The presence of a work zone increases disturbances to traffic flow and produce high cognitive workloads for drivers which can increase the safety risks. There was an increase of about 11% in work zone-related fatalities from 2010 to 2014, despite a small decrease in non-work zone-related fatalities in the U.S. (1). Work zone safety is a major concern for construction workers, travelling publics, and transportation safety professionals. Work zone impacts on safety creates a strong need to protect road users and construction workers.

Speeding considered to be one of the main unsafe driver behaviors elevating the safety risks in the work zone. The Federal Highway Administration (FHWA) crash facts indicated speeding as a contributing factor to 28% of work zone crashes in 2014. A series of countermeasures have been used to attract drivers' attention to comply with work zone conditions and reduce their speeds. There is limited information about which safety features are the most effective in accomplishing this objective.

It is essential to learn how drivers react to various safety features throughout the work zone in order to find the features' effectiveness. Due to the presence of multiple safety features throughout the work zone, drivers may react differently to each measure, which creates a changepoint in speed time series data. Changepoint analysis is a statistical tool designed to achieve homogeneity within time series data. Multiple changepoints detection, also known as time series segmentation, is basically finding a time instance when statistical properties of data change.

The speed trajectory time series data from SHRP 2 work zones at a rate of 0.1 seconds (10 HZ) were used to develop changepoint models by utilizing Pruned Exact Linear Time (PELT) algorithm to accurately and efficiently estimate the location of changepoint in mean speed reacting to safety features such as DMS, speed limit signs, speed feedback signs, flashing arrows, merge signs, and so on. The model created mean speed data partitioned into regions in reaction to different safety measures.

The analysis revealed promising results regarding driver's reaction to different safety measures in work zones by identifying prime changepoint locations in mean speed time series data. This method helped to identify the effect of safety features on changing drivers' speed behavior and subsequent modeling.

### 3.1 Introduction

The presence of a work zone increases disturbances to traffic flow and produces high cognitive work load for drivers, which can increase the safety risks. According to the National Work Zone Safety Clearinghouse, there was an increase of about 11% in work zone-related fatalities from 2010 to 2014, despite a small decrease in non-work zone-related fatalities in the U.S. (1). Work zone safety is a major concern for construction workers, travelling publics, and transportation safety professionals. Work zone impacts on safety creates a strong need to protect road users and construction workers.

There are a large number of factors contributing to work zone safety, but it is mainly believed that the major contributing factors are speeding, inattentive driving, and other unsafe driver behaviors.

Transportation agencies make extensive efforts to lower the safety impacts of work zones on road users and construction workers through effective planning, scheduling, and

operating mechanisms (2). Therefore, the knowledge of contributing factors to work zone crashes and a detailed understanding of associated risk factors in work zones is vital to making informed decisions on providing the appropriate safety strategies and countermeasures.

Past research indicated significant progress has been made in work zone crash frequency, but the major challenge is the lack of usage of more advanced models due to the deficiencies of data associated with work zones (2-5). Accurate work zone crash data are scarce as studies have indicated. Most studies solely rely on crash data derived from police crash reports. The crash reports are subject to a number of issues such as missing data, under-reporting, and incomplete work zone data. Also, whether a crash is coded as work zone-related depends mainly on an officer's interpretation. In some cases, work zone traffic control may be present but the work zone was not active when the crash occurred. In other situations, the impact of a work zone might extend beyond the work zone boundaries such as congestion or queuing upstream of the work zone, but the crash is not coded as work zone-related.

Drivers react to the presence of a work zone's advanced warning sign, merge sign, lane closure sign, and other countermeasures such as DMS, flashing arrow, speed limit, speed feedback, and similar signs. These countermeasures tend to get drivers' attention to reduce their speed and react to signage, which help them safely traverse the work zone area. It is essential to learn how drivers react to various measures throughout the work zone in order to find countermeasures' effectiveness. Due to the presence of multiple signage and countermeasures throughout the work zone, drivers may react differently to each measure, which creates a change-point in speed time series data.

Changepoint analysis is a statistical tool developed to achieve homogeneity within time series data. This can be achieved by partitioning the time series data into a number of homogeneous segments. Multiple changepoints detection, also known as time series segmentation, is basically finding a time instance when statistical properties of data change.

Multiple changepoint analysis is an appropriate method for analyzing speed time series data from SHRP 2 NDS to identify when the statistical property of mean speed changes. Multiple changepoint models can be utilized to accurately and efficiently detect the abrupt changes in mean speed associated with multiple safety measures applied in work zones.

### **3.1.1 Background on SHRP 2 Naturalistic Driving Study**

The SHRP 2 NDS is the largest and most comprehensive driving-based research study ever conducted. NDS is designed to observe driver's daily driving behavior in a natural setting environment with no experimental control. The Virginia Tech Transportation Institute (VTTI) led this project implementation and coordination. More than 3,100 female and male drivers aged 16 to 98 were recruited in six unique and geographically distributed sites (New York, Florida, Washington, North Carolina, Indiana, and Pennsylvania). The participants' vehicles were equipped with a Data Acquisition System (DAS), which consists of sensors, cameras, a Geographic Positioning System (GPS), vehicle network, lane tracking system, accelerometers, eye-tracking system, and data storage. The DAS sensors collected data such as speed, GPS, and acceleration, while four cameras collected forward, rear, driver face, and over the shoulder videos. Over 3,100 drivers made over 5 million trips over the two-year study period, resulting in more than 30 million data miles and 4 million gigabytes of data. NDS collected a variety of variables regarding driver's daily driving behavior without any



experimental control. Most of the variables were collected at high frequency (10 HZ), which is every 0.1 second (6).

### **3.1.2 Background on SHRP 2 Roadway Information Database**

The Roadway Information Database (RID) was conducted to collect roadway information data for the roads driven by drivers in SHRP 2 NDS. The Center for Transportation Research and Education (CTRE) at Iowa State University led the implementation and coordination of the project, which used mobile data collection vans to collect about 12,500 center line miles of roadway data elements in the six NDS sites. In addition, other existing roadway data from government, public, and private sources, as well as supplemental data, were utilized to populate a roadway element dataset linkable to NDS trips to support a comprehensive safety assessment of driver behavior. The identified roadway data elements included information on roadway alignment, number of lanes, lane type and width, intersection types and location, lighting, signage, median type, barriers, rumble strips, and other features. The RID integrated 511 data provided by states with roadway data that was collected throughout NDS study locations. The integrated 511 data were the primary source of identifying work zone locations and duration (7).

## **3.2 Literature Review**

Limited research has been conducted to develop models on the effectiveness of speed reduction safety measures in work zones. Work zones are creating change to traffic patterns, which require speed reductions. The proper usage and placement of traffic control devices are an important part of every work zone management plan where the safety of construction workers and the traveling public is the major concern of transportation agencies. The

National Highway Transportation Safety Administration (NHTSA) identified speeding as the major contributing factor in 30 percent of fatalities (8). The FHWA crash facts indicated speeding as a contributing factor to 28% of work zone crashes in 2014 (9). Speeding is clearly a major contributing factor to work zone crashes (10, 11). It has raised awareness on the negative effects of speeding in work zones, which increased emphasis on reducing speed and enforcing compliance with work zone speed limits. In order to determine the impact of safety measures on reducing vehicle speed and attracting drivers' attention, a literature review has been conducted to find the major findings associated with speed management in work zones.

Prior research revealed the use of signs to reduce the speed of traffic through work zones had different ranges of effectiveness. It depended on various factors such as geometry, sight distance, and the posted speed limit at a work zone location (12). The effectiveness of the speed reduction signs can sometimes be varied for unknown reasons that can be mainly attributed to driver behavior, which has not been truly investigated.

Research in identifying the effectiveness of traffic control devices in work zones indicated the most effective measures in reducing mean speed and speed variance are speed display signs, flaggers, and automated radar detections with citations issued to vehicle owners. On the other hand, pavement markings, signs, and other standard traffic control devices were found to be ineffective in reducing vehicle speed in work zones (13-17).

Studies on the effectiveness of Changeable Message Signs (CMS) in reducing speeds and informing traffic about upcoming work zones are more effective than traditional work zone warning sign (18, 19). A study by Zech and Mohan (2008) measured the effect of three commonly used CMS in reducing vehicle speeds in work zones. The study recorded the

speed of 180,000 vehicles on Interstate 90 and found the “WORK ZONE/ MAX SPEED 45 MPH/ BE PREPARED TO STOP” message was effective in reducing the vehicle speeds between 3.3 and 6.7 mph. The study concluded a properly selected CMS message can significantly reduce traffic speeds in work zones (20).

Li and Bai (2011) used a CMS at 250, 750, and 1,250 feet from a work zone displaying “WORK ZONE AHEAD SLOW DOWN.” This revealed a CMS will be more effective in reducing vehicle speed if placed between 556 to 575 feet from the work zone. Alternative messages on CMS, such as “YOUR SPEED IS ## MPH” changing to “SLOW DOWN,” followed by “MIMIMUM FINE \$200,” had positive effects on getting drivers’ attention to reduce their speed. The results indicate the percentage of drivers who drive 5, 10, 15, 20, and 25 miles over the speed limit were reduced by 20, 20, 10, 3, and 0.3 percent, respectively (21).

Dynamic speed signs, which can be trailer mounted or mounted on a permanent location such as a light pole, can use laser detectors to measure the speed and sign display the approaching vehicles’ speed to drivers. Studies have determined that the use of dynamic speed sign in work zones can reduce a vehicle’s speed by as much as 5 mph (22, 23). Several other studies indicated speed reductions ranged between 1 and 8 mph in upstream of the taper area had greater effectiveness within the work area, reducing speed from 3 to 6 mph (19, 24-27). The Petsi and McCoy’s study results revealed a positive impact on the average speed reduction for the first week, but the sign effectiveness was reduced during the second week (28).

The presence of a speed photo enforcement van in a work zone, which has the same function as red light cameras, was successful in lowering vehicle speeds from 6.4 to 8.4 mph.

In a different study, it was effective in reducing the speed by as much as 7.9 and 6.6 mph for cars and heavy vehicles, respectively (29).

The use of speed trailer along the side of an urban road, which flash the speed if the vehicle is traveling over the speed limit, was effective in reducing speeds by up to 2 mph (29).

The vast majority of the past research looked at the effectiveness of a single speed countermeasure in a work zone. Hildebrand and Mason (2014) evaluated the effectiveness of safety measures in three different rural work zones with a semi-controlled environment in Canada. Speed data were collected at three spots, including 500 m upstream, 75 m upstream, and immediately adjacent to activity area to approximate the speed profile of vehicles approaching. The safety measures identified and tested were Floating Speed Zones (FSZ), Traffic Control Person (TCP), Narrow Lanes, Radar Speed Display Board (RSDB), Variable Message Sign (VMS), and a Fake Police Vehicle. These traffic control measure were singularly and collectively evaluated to identify the most effective measure(s) in slowing the traffic through the identified work zones. The study concluded a combination of TCP and FSZ had the greatest effect in speed reduction by 23 km/h. The Fake Police Vehicle and FSZ and the combination of RSDB and FSZ both made the traffic slow down by an average of 19 km/h (39).

A number of research studies were conducted to evaluate speed management strategies and effectiveness in highway work zones. Many of the past studies were conducted in a controlled environment and have produced mixed results in identifying the speed countermeasure's effectiveness. The majority of previous research collected vehicle speeds using roadside radar guns and road tubes at a limited number of locations, then approximated

speed profile based on a few observations. A series of countermeasures have been used to attract drivers' attention to comply with work zone conditions and reduce their speeds. There is limited information about which safety features are the most effective in attracting drivers' attention in work zones. Past research indicated the effectiveness of the speed reduction measures can sometimes have considerable variations for unknown reasons. These unknown reasons can be mainly attributed to driver behavior which has not been truly investigated. The NDS developed and collected by the SHRP 2 provide a unique opportunity to observe actual driver behavior and understand how they react to a series of safety measures intended to get their attention in work zones.

### 3.3 Data Descriptions

Data for this chapter were acquired mainly from the SHRP 2 NDS and the SHRP 2 RID. The NDS collected time series data utilizing the Data Acquisition System and video data collected by 4 cameras (6). This study uses vehicle speed time series data attributed to work zones. As speeding has been identified as one of the major contributing factors to work zone crashes, it is very important to observe and understand how drivers react to multiple safety measures applied in work zones to get their attention and reduce their speed.

The data used in this study went through a quality assurance process. Since most of the data were collected from sensors in real world driving environments, missing data were observed as one of the main issues. In order to control and assure data quality in the analysis, the percentage of missing data were summarized for each identified speed trace in a work zone. The trace with more than 25% of missing network speed data were removed from the dataset. Speed traces with missing values were interpolated assuming a constant increase or decrease.

### 3.3.1 Data Collection and Data Reduction

The major effort on the data collection part of this research was identifying work zone locations within SHRP 2 data. The RID contains 511 data for the most states involved in NDS for the duration of study (October 2010 to November 2013). The 511 data and collected variables were very different among the states. A major field in 511 data that contain information about the potential work zones was the traffic event description. This field was queried for potential work zones by using key words such as “road work”, “lane closure”, “construction”, “maintenance”, “cross over”, or “head-to-head”. There were about two million records that needed to be searched for the potential work zones. The RID did not have 511 data for the state of Indiana, so this state was not included in the analysis.

The 511 data also contain information on the beginning and end of traffic events. Based on that, the duration of events which were work zones in our case were calculated. The work zones with durations of less than three days were removed due to the low possibility of having sufficient number of NDS time series traces for the short term work zones. As a result, 9,290 potential work zones were identified. The identified work zones were overlaid on NDS trip density data and were mapped to the corresponding roadway link ID in the RID. The identified locations for 9,290 potential work zones were sent to VTTI to acquire the number of NDS time series traces, unique drivers, and driver demographic data associated with the links of interest that occurred within the duration of work zones.

VTTI provided a list of potential trips associated with the links of interest along with driver information on those trips. The data were examined and work zones with at least 15 potential trips were selected, resulting in 1,680 potential work zones. The next step was requesting time series data associated with identified potential work zones. The estimation of

the physical extent of each potential work zone was needed to increase the likelihood that the actual work zone was included. For this purpose, the identified roadway links were mapped to RID and the corresponding link extracted. The dynamic segmentation function in ArcMap was utilized to add links to the upstream and downstream of each identified work zones.

The next step on this extensive data reduction effort was to submit a list of identified link IDs to acquire a sample time series trace and corresponding forward video for each potential work zone. About 3,000 traces were received and the forward video was reviewed to determine if a work zone was actually present. Data collected from forward videos are shown in Table 3.1.

**Table 3.1 Extracted work zone characteristics from forward videos**

Presence of work zone (yes or no)	Locations of channelization
Lane closure Right or left	Type of channelization
Number of lanes closed	Spatial locations of work zone start and end points
Shoulder closures Right, left, or both	Presence and locations of workers
Dynamic message sign	Presence and locations of equipment
Types and locations of barriers (e.g., barrels)	Lane shift
Work zone speed limit	Active work zone

A set of criteria used to identify an active work zone included lane closure, shoulder closure, worker present, and equipment present. In some locations, where barrels were present along the side of roadway, the work zone was considered inactive and was excluded. At this stage two main criteria to request the final set of time series data was set and confirmed. The forward videos were used to identify the true beginning and end points of each work zone and confirm if the work zone was actually active. A set of 118 coded active work zones including various work zone configurations (such as lane closure and shoulder

closure) and types (such as multi-lane divided and 4-lane divided) were requested. Around 4,800 time series traces with associated forward/rear video images were received from VTTI. At this stage traces with more than 25% of missing network speed data were removed from the dataset. Speed traces with missing values were interpolated assuming a constant increase or decrease. All congested traces were removed and only traces with free flow conditions were kept in the analysis. Also traces with very poor image quality were excluded due to the inability of identifying the vehicle's position or confirming if indeed it was an active work zone.

The final step of the process was to identify work zone features such as work zone signage, the start of the work zone, the start of the taper, and the start of work area. The location of features identified in the forward video were spatially located by noting the nearest video time stamp. The time stamp was then matched with the one in the time series data utilizing interpolation. The location of features relative to the start of the taper, which was identified as zero, were calculated using the speed of the vehicle. In addition, the position of the vehicle relative to each safety feature was calculated using the same technique.

### **3.3.2 Identification of Work Zones of Interest**

This study focused on the analysis of vehicle speeds data in work zones. The objective of the study was to analyze various work zone characteristics such as left lane closed, right turn closed, left shoulder closed, right shoulder closed, both shoulders closed, and lane shifts. It was also desired to analyze different types of speed reduction countermeasures, such as lane closed sign, Dynamic Message Sign (DMS), Dynamic Speed Feedback Sign (DSFS), work zone speed limit sign. A total of nine work zones with different



characteristics has been selected for the analysis in this study. The characteristics of the nine selected work zones are shown in Table 3.2.

**Table 3.2 List of work zone characteristics for the sample work zones**

Work Zone	Work Zone Characteristics	Road way Speed Limit (mph)	Work Zone Speed Limit (mph)	Number of speed profiles (Number of Unique Drivers)				
				Overall	Female	Male	Inside Lane	Outside Lane
1	Left lane closed 4-lane divided DMS after 1st WZ warning sign	65	↓ 55	62 (35)	33 (17)	29 (18)	36 (23)	26 (21)
2	Left lane closed 4-lane divided DMS after lane closed sign	65	↓ 55	42 (17)	29 (9)	13 (8)	26 (14)	16 (8)
3	Left lane closed 4-lane divided DSFS after 1st WZ warning sign	55	↓ 45	76 (30)	27 (15)	49 (15)	39 (20)	37 (19)
4	Left lane closed multi-lane divided	70	70	55 (22)	34 (11)	21 (11)	35 (15)	20 (12)
5	Right lane closed 4-lane divided DSFS after 1st WZ warning sign	55	↓ 45	68 (29)	24 (15)	44 (15)	53 (27)	15 (9)
6	Left shoulder closed 4-lane divided	55	55	40 (37)	18 (17)	22 (19)	27 (24)	13 (12)
7	Right shoulder closed 4-lane divided	65	65	41 (28)	18 (11)	23 (17)	24 (16)	17 (14)
8	Both shoulder closed 4-lane divided	65	65	49 (12)	30 (5)	19 (7)	17 (8)	32 (9)
9	Lane shift 4-lane divided	55	55	37 (20)	19 (9)	18 (11)	16 (12)	21 (10)

There are four work zones with left lane closures, three of those are four lane divided, but with different types of safety measures such as DMS or DSFS. Work zone one included a DMS as a safety measure introduced right after the first work zone warning sign, while the DMS in work zone number two was located after the merge sign. Work zone three contained a DSFS that was located 2,200 feet upstream of the taper. Work zone number four was on a multi-lane divided highway and does not include any DMS or DSFS as safety measures. There are other differences between the types and locations of safety measures in all work zones of interests, which will be discussed in the results analysis section.

The number of traces per driver are shown in Table 3.3. The first column shows number of traces per driver and the following columns show the number of drivers in each work zone that correspond to the number of traces.

**Table 3.3 Number of traces per driver in all work zones**

Number of Traces per Driver	Number of Drivers								
	WZ-1	WZ-2	WZ-3	WZ-4	WZ-5	WZ-6	WZ-7	WZ-8	WZ-9
1	19	13	17	16	13	32	19	5	14
2	9	1	4	3	5	4	6	1	3
3	3	2	3		7		2	1	1
4	4		2		1		1	1	1
5			1					1	
6		1	1	2	2				
7			1					1	
8			2		1			1	
10									1
15		1						1	
21				1					
Total Number of Traces	62	42	76	55	68	40	41	49	37

For example, work zone one had 19 drivers, each with a single trace, 9 drivers, each with 2 traces, 3 drivers, each with 3 traces, and 4 drivers, each with 4 traces.

The forward video of each trace was observed to locate the start and end of the work zone, the start of the taper, the start of the work area, and all individual safety measures. This was accomplished by spatially locating the interested features in the video and matching the time stamp in the video with that of the time series data by interpolation. Then, the location of features relative to the start of the taper, identified as zero, was calculated using the speed of the vehicle. A list of coded features in work zones is shown in Table 3.4.

**Table 3.4 Work zone features extracted from forward videos**

<b>Coded Features in Work Zones</b>	
Work Zone 1st Warning Sign	Work Zone Speed Limit Sign
Work Zone Advisory Sign	Presence of Barrels
Work Zone 2nd Warning Sign	Presence of Jersey Concrete Barrier
Work Zone 3rd Warning Sign	Presence of Cones
Work Zone 4th Warning Sign	Merge Sign
DMS	Lane Closed Sign
DSFS	Start of the Taper
Flashing Arrow	Start of the Work Area

### 3.4 Methodology

A changepoint is a sudden variation in time series data. Changepoint detection is useful in the modeling and predicting of time series data. It has discovered application areas such as medical imaging, climatology, finance, oceanography, and speech and image analysis (30-33).

Changepoint analysis is a statistical tool designed to achieve homogeneity within time series data. This can be achieved by partitioning the time series data into a number of homogeneous segments. Multiple changepoints detection, also known as time series segmentation, is basically finding a time instance when statistical properties of data change. In time series segmentation, data is divided into a sequence of separate segments to show the underlying properties of its source of isolation. It is used to locate stable periods of time or to identify changepoints (30, 32).

#### 3.4.1 Background on Multiple Changepoints Detection Algorithms

Changepoint detection is the process of finding abrupt changes in time series data when the statistical property of time series changes. Considerable efforts have been devoted to efficiently and accurately identify multiple changepoint locations in regard to time series data. This topic has been widely studied over the last several decades in statistics and data mining (30-33). There are two major issues addressed in the literature. One is determining the parameters affected by changepoints such as mean and the second is selecting the number of changepoints. The issue of determining parameters affected by changepoints has led to main research path: Hidden-Markov-based methods and segmentation methods (31-33). Literature indicated segmentation methods, which are based on segmentation criteria such as likelihood ratio, least-squares, and the cumulative sum of squares, are the most common.

There are three major segmentation methods for multiple changepoint analysis. The first is Binary Segmentation (BS), proposed by Scott and Knott (34), which is an approximate algorithm. This method first finds a single changepoint in the entire time series data which splits data to two segments at the changepoint location, if a changepoint is found. The process continues until no changepoints can be found in any parts of the data. BS is an approximate minimization, as any changepoint location is conditional on changepoints identified previously. BS is quick as it only consider a subset of possible solutions. The speed comes at the expense of accuracy of the resulting identified changepoints (33-35).

The second method is Segmentation Neighborhood (SN), which was proposed by Auger and Lawrence, 1989 (36) and further explored by Bai and Perron, 1998 (37). The SN algorithm uses a dynamic programming technique to obtain the optimal segmentation for  $m+1$  changepoints reusing the information that was calculated for the last changepoints ( $m$ ). Although the SN is an exact method, the computational complexity is considerably greater than that for BS.

The third segmentation method is improved Optimal Partitioning (OP). Killick et al. (32) proposed this new approach to search for multiple changepoints in 2012. The Pruned Exact Linear Time (PELT), like SN, provides an exact segmentation. The main assumption that controls the computational cost is that the number of changepoints increases linearly as the dataset grows. The pruning reduces the computational cost while maintaining the exactness of the resulting segmentation (33). It was revealed that the PELT method does substantially more accurate segmentation than the BS. In this research we adopt PELT algorithm as it produces a computational efficiency which is more suitable for big data processing applications (33).

### 3.4.2 Pruned Exact Linear Time (PELT) Algorithm

With an increased collection of time series data, there is a growing need for the ability to estimate the locations of multiple changepoints accurately and efficiently. PELT algorithm has been identified to be the best available segmentation method to efficiently and accurately identify the number and locations of changepoints in time series data, particularly for big data processing applications.

Changepoint analysis is a statistical tool designed to achieve homogeneity within time series data. This can be achieved by partitioning the time series data into a number of homogeneous segments. Multiple changepoints detection, also known as time series segmentation, is basically finding a time instance when statistical properties of data change. In time series segmentation, data is divided into a sequence of separate segments to show the underlying properties of its source of isolation. It is used to locate stable periods of time or to identify changepoints (31-33).

Let's define our speed time series data set as:

$$V_{1:n} = (V_1, V_2, \dots, V_n)$$

A changepoint may occur within this set when there exists a time:

$$\tau \in \{1, \dots, n-1\}$$

where statistical properties of:

$$\{V_1, \dots, V_\tau\} \text{ and } \{V_{\tau+1}, \dots, V_n\}$$

are different in some way (38). In multiple changes, we have a number of changepoints,  $m$ , together with their positions:

$$\tau_{1:m} = (\tau_1, \dots, \tau_m)$$

Each changepoint position is an integer between 1 and  $n-1$ . We define  $\tau_0 = 0$  and  $\tau_{m+1} = n$ , and assume that the changepoints are ordered so that  $\tau_i < \tau_j$  if,  $i < j$ . Therefore the  $m$  changepoints will split the data into  $m + 1$  segments, with the  $i$ th segment containing data

$$V_{(\tau_{i-1}+1):\tau_i}$$

The aim of the analysis is to efficiently and accurately estimate the location of multiple changepoints by minimizing Formula 1:

$$\sum_{i=1}^{m+1} [C(V_{(\tau_{i-1}+1):\tau_i})] + \beta f(m) \quad (3.1)$$

Where  $C$  is a cost function for measure of fit and  $\beta f(m)$  is a penalty to guard against overfitting. There were several penalty functions used within changepoint analysis with PELT algorithm, such as SIC (Schwarz information criterion), BIC (Bayesian information criterion), and AIC (Akaike information criterion). There was also the option of manual penalty value provided to adjust for an overfitting issue (31).

### 3.4.3 Application of PELT for Driver Speed Behavior in Work Zones

The speed time series data at a rate of 0.1 seconds (10 HZ) in work zones were used to develop changepoint models by utilizing a PELT changepoint package (cpt) in R to accurately and efficiently estimate the location of multiple changepoints for the mean of speed time series profile.

The data could be partitioned into regions that lie in between different important events. In our case, events could be a series of safety features such as DMS, speed limit, speed feedback, merge, flashing arrow, and similar signs.

Several safety features are introduced throughout the work zone to get drivers' attention to slow down as shown in Figure 3.1, which reveals the speed profile of a single trace. This speed profile is from 2,000 meters upstream of the start of the taper (point zero), all the way through the work area and to the end of the work zone. It also shows the types and locations of various work zone safety features applied to promote safe driving. The units in this figure are identical to that collected in the NDS study. In the analysis, the distance unit was converted to mile and the speed unit was converted to miles per hour.

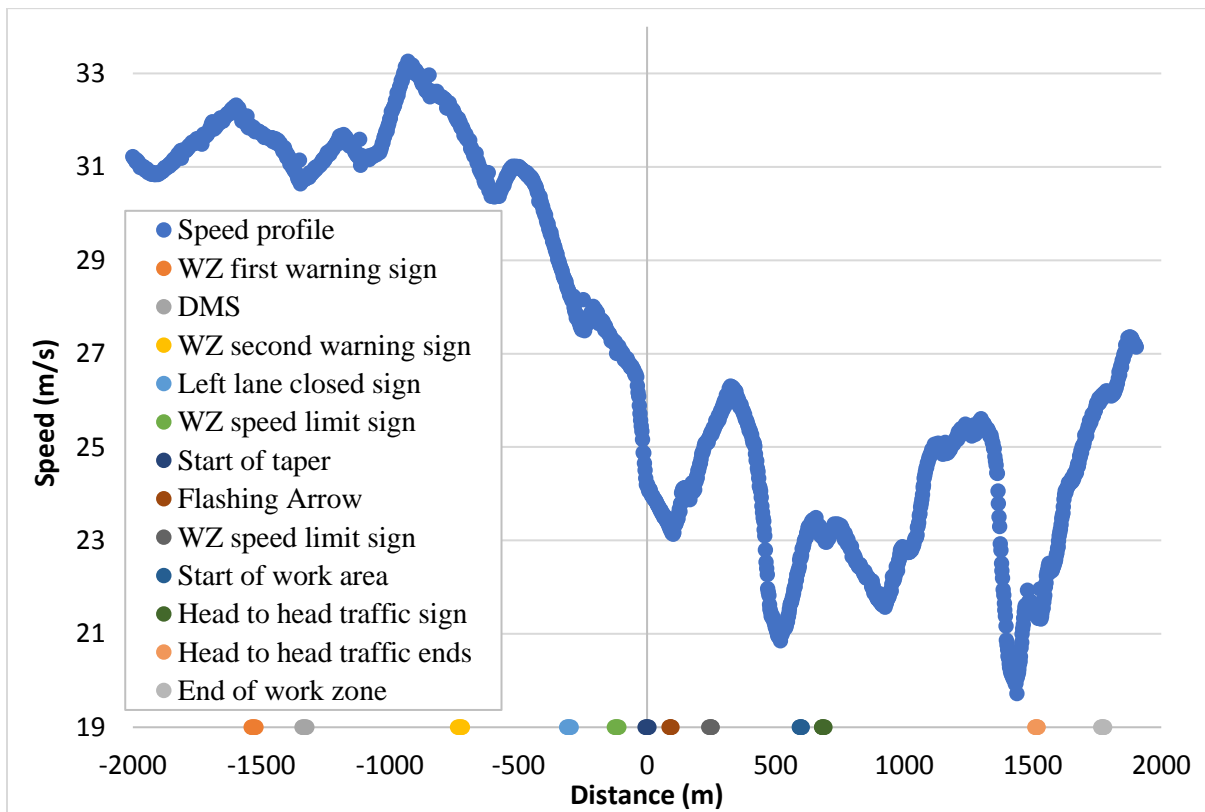

**Figure 3.1 Applied safety measures in work zone one**

Each safety feature might have a different effect on vehicle speed throughout the work zone, therefore it could be a cause of a separate changepoint detected in the work zone.



### 3.5 Multiple Changepoint Analysis Results

The potential changepoints in the mean of multiple speed time series data over various work zones with different characteristics have been studied. A multiple changepoint analysis model was used to create a model predicting driver reaction to various work zone safety measures. Time series data at a rate of 0.1 seconds were used to develop changepoint models by utilizing a PELT changepoint package (cpt) in R to accurately and efficiently estimate the location of multiple changepoints for the mean of speed time series traces.

There were nine work zones in the study with different characteristics. Various safety countermeasure types and locations were introduced in work zones, which involved left lane, right lane, lane shift, and shoulder closure scenarios as shown in Table 3.2, and will be discussed in the following sections. In each work zone five models were created which consist of all, male, female, closed lane, and open lane driver groups. These models helped to observe and differentiate drivers' behaviors in each group in relation to a comparable group (e.g. male versus female drivers).

In this study the location of work zone Temporary Traffic Control Devices (TTCD) were confirmed according to the Manual of Uniform Traffic Control Devices (MUTCD) guidelines. It provides guidance on the use and implementation of TTCD. The implementation of TTCD usually follows the agency guidelines for road safety, considering factors such as traffic conditions, traffic volume, site conditions, and the cost effectiveness of safety devices. The selection of the TTCD depends on the nature of the road work. There are many different applications of work zones which are demonstrated in Part 6 of MUTCD (40).

Figure 3.2 shows a typical application of suggested type and placement of TTCD in a work zone. There are four signs associated with the stationary lane closure in the schematic, including the first warning sign, second warning sign, lane closed sign, and flashing arrow.

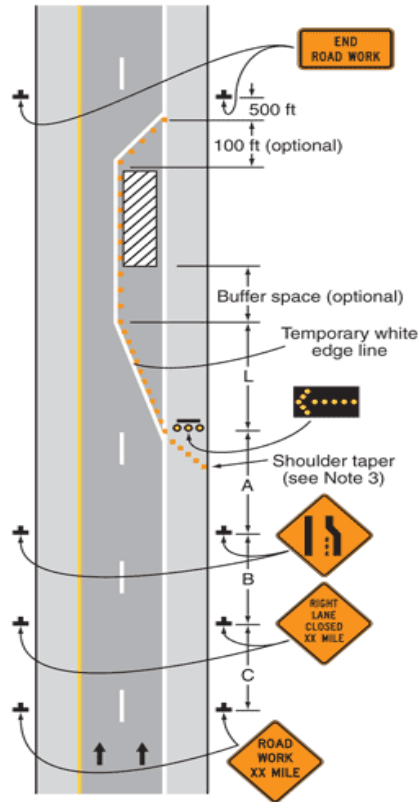

**Figure 3.2 Typical TTCD application for a stationary lane closure arrangement on a divided highway (FHWA 2009)**

The placement locations are identified and the dimensions are shown as A, B, and C. These dimensions can be calculated using the information in Table 3.4 which are defining the letter codes for the application of the TTCD diagram. The dimension A is the distance from the point of restriction to the location of the first sign which depends on the type and speed of the roadway as shown in Table 3.5. The first sign is the closest sign to the work area. The letters B and C are dimensions showing the distances between the first and second signs and between the second and third signs, respectively. The third sign is the furthest sign upstream

of the work area. All nine work zones in this study were selected in accordance with the suggested locations of the TTCD with distance requirements.

**Table 3.5 Recommended advanced warning sign minimum spacing (FHWA 2009)**

Roadway Type	Distance Between Signs		
	A	B	C
Urban (low speed)	100 ft.	100 ft.	100 ft.
Urban (high speed)	350 ft.	350 ft.	350 ft.
Rural	500 ft.	500 ft.	500 ft.
Expressway / Freeway	1,000 ft.	1,500 ft.	2,640 ft.

The road types of all nine work zones are expressway/freeway with high speed limits. Therefore, the suggested distances of the signs were compared with the expressway/freeway category of Table 3.4. The distance of the closest sign to the point of restriction was equal to or greater than 1,000 feet and the distance of the furthest sign upstream of the transition point was also greater than 2,640 feet for similar conditions.

The results of the models, developed for various work zone characteristics, are presented to identify the effects of a countermeasure or a series of countermeasures collectively on speed reduction. The first scenario will be discussed in great detail and the analyses of the remaining scenarios will be focused in the major findings.

### 3.5.1 Left Lane Closure with a DMS after Work Zone first Warning Sign

The changepoint model with PELT algorithm was applied to the 62 speed time series traces of vehicles traveled through a left lane closed work zone on a rural 4-lane divided highway.

There were a series of safety measures applied in work zone one to catch drivers' attention which are shown in Figure 3.3. The roadway speed limit was 65 mph and changed

to 55 mph in the work zone. There is only one speed time series trace in Figure 3.3 from one-quarter mile upstream of the work zone's first warning sign all the way through the work area. The one-quarter mile upstream location of the first warning sign was chosen to observe drivers' behavior before that sign became visible to them. The vertical orange dashed-lines represent the locations of safety features throughout the work zone. The first work zone warning sign was placed at about one mile upstream of the work area which is slightly different than the calculated distance from the point zero (start of taper) on this study.

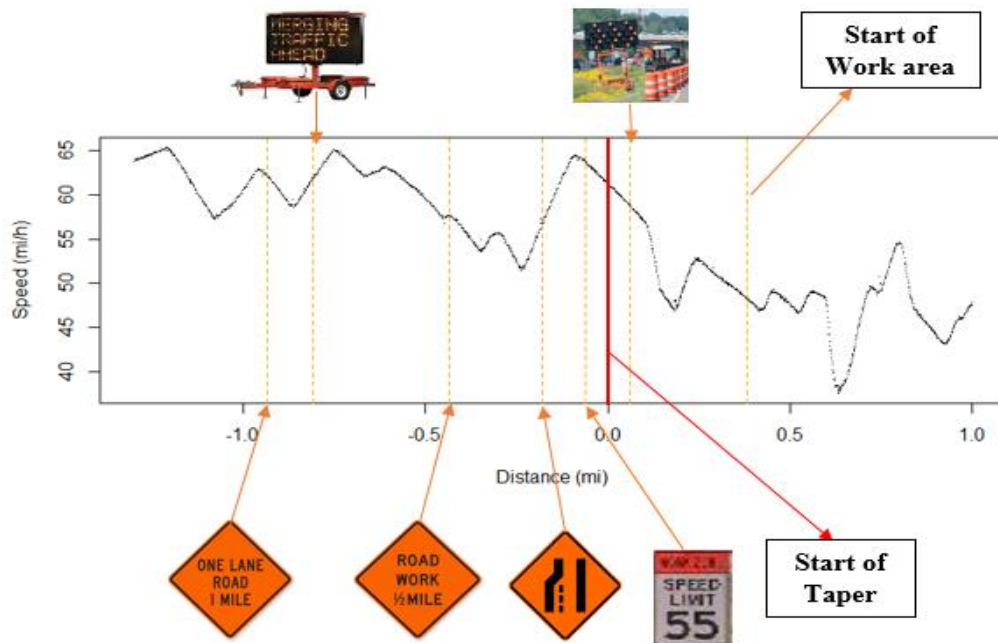

**Figure 3.3 Work zone one with left lane closure and utilized safety features types and locations**

The start of taper was selected as the location where the transition or the point of restriction starts, as discussed in the MUTCD typical diagram. Here the first point of restriction was where the barrels were introduced in the shoulder to gradually close the left lane.

The five categories examined in this study were overall, male, female, closed lane, and open lane drivers. The results of all models are discussed in the following sections.

### 3.5.1.1 Overall Drivers' Speed Profiles

There were 62 speed profiles in this work zone which were from a one-quarter mile upstream of the first work zone warning sign, all the way through the work area, and continued to one mile after the start of the taper. Figure 3.4 shows a visual representation of the speed time series distributions for all driver traces. Boxplots in green color were used to show how each speed profile has been distributed throughout the work zone. A brief observation of the plot reveals a high variability in speed ranged between 50 and 75 mph. The high variation was observed both within and between speed profiles. The blue line is the actual speed limit of the roadway and the red line represents the work zone speed limit. The speed profiles mainly hovered around 65 mph, the roadway speed limit, and a low proportion of the speeds reached 55 mph, the work zone speed limit.

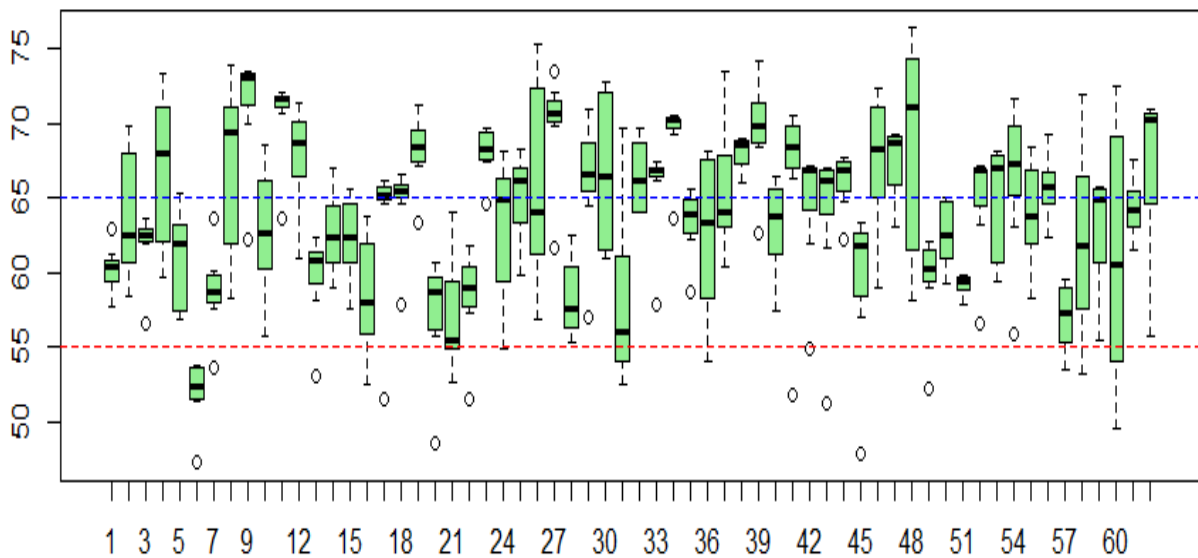

**Figure 3.4 Visual illustration of work zone 1 speed profiles distributions for all drivers**

The time series data for work zone one are shown in Figure 3.6 (a) through (d). Part (a) shows the raw speed time series traces from 1.3 mile upstream of the taper to the work area. The calculated mean of the speed times series data for every 8.8 feet is shown as a thick

red line in part (b). The distance of 8.8 feet nearly corresponds to every 0.1 second. The entire 2.3 miles of data corresponds to an average of 1,380 observations per trace which is lasted about 2.3 minutes. This is the average time for all 62 traces to travel from one-quarter mile upstream of the first warning sign all the way to one mile after the start of the taper.

The mean speed of time series traces was fitted in the multiple changepoint model to estimate the maximum number of changepoints using the PELT algorithm as shown in part (c). The PELT changepoint model with a default penalty detected 14 changepoints which provided 15 homogeneous segments. A glance at the model, with very small segment lengths and minimal mean speed changes between the segments, suggests the model is too sensitive to changes and overfitted. To guard against the overfitting the penalty value needed to be adjusted. As discussed earlier, the objective of the model is to efficiently and accurately estimate the location of multiple changepoints by minimizing the cost in Formula 3.1, which consists of the cost function which is the measure of the fit and the penalty to guard against overfitting.

The decision on choosing an appropriate penalty typically depends on many factors, such as the size of the change and the length of the segments in a stable condition, both of which are unknown prior to an analysis. In current practice, the choice of penalty is often assessed by plotting data and observing the changepoints to find if they are reasonable. The minimum segment length in a stable condition was observed to be 80 points or 8 seconds, which reflected the best fit for the data in this study. The sensitivity analyses were conducted by increasing and decreasing the penalty values which are illustrated in Figure 3.5. The top graph shows the optimal chosen penalty of  $45 \cdot \log(n)$ .

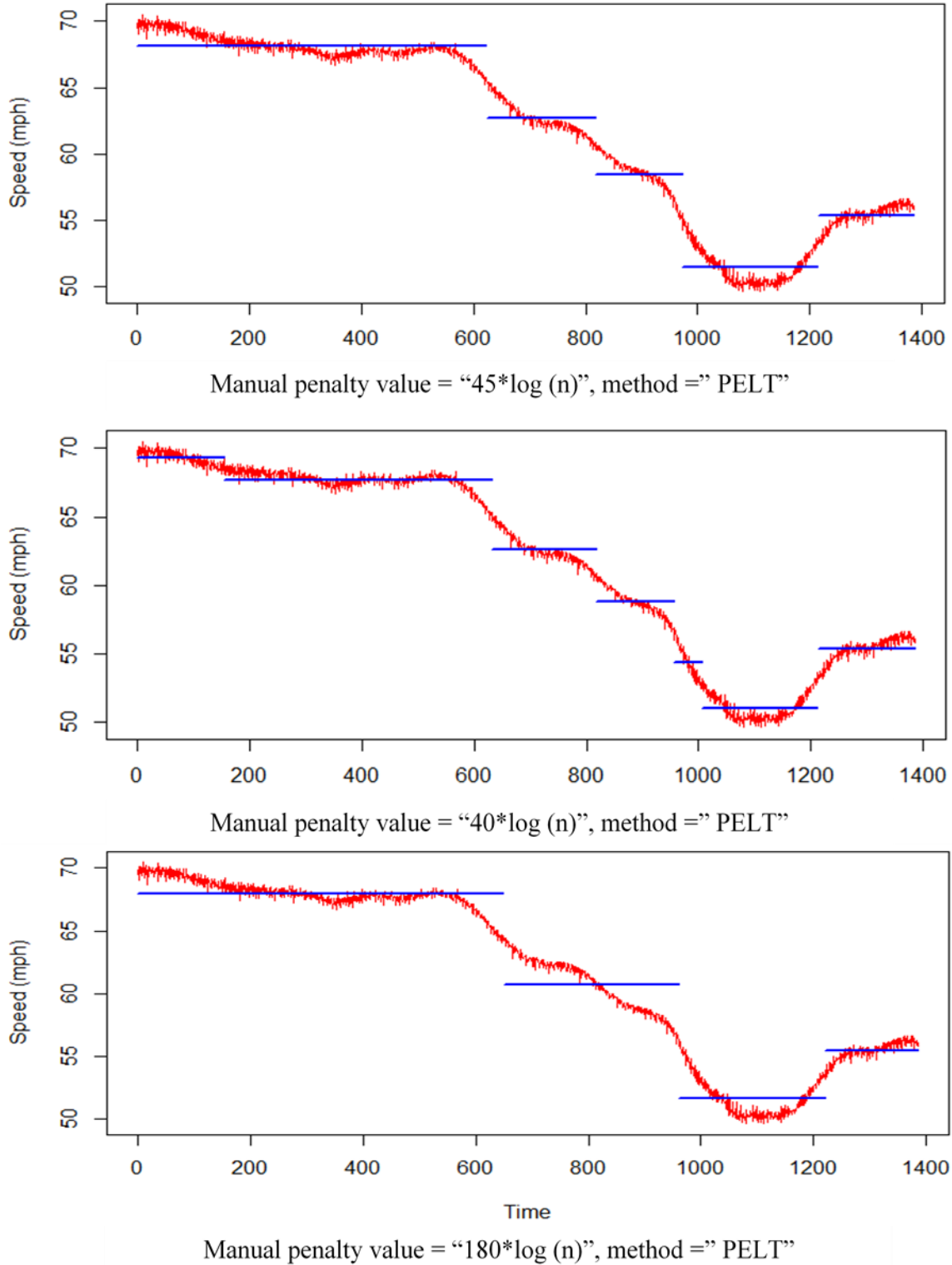

**Figure 3.5** Changepoint detection model sensitivity analysis  
Optimal applied penalty (top), over-fitted (middle), and under-fitted (bottom)

The middle graph represents a lower penalty than the optimal chosen at  $40 \cdot \log(n)$ , which created two additional changepoints, one at the upstream with a segment length of 154 observations or 15.4 seconds and a very short segment closer to the work area with a length of 49 observations or 4.9 seconds. This shows the model is too sensitive as it detected a changepoint at a location with no apparent stable condition.

The penalty was increased from the optimal value by 5 points increments and the results in terms of changepoints didn't change until a penalty of  $180 \cdot \log(n)$  was reached as shown in the bottom graph in Figure 3.5. Therefore, the changepoint model in the top graph which detected four changepoints illustrated it has the optimal applied penalty for this work zone. This sensitivity analysis as shown in Figure 3.5 was repeated for all work zones to determine the optimal penalty value.

To overcome the issue of overfitting, a manual penalty was increased to  $35 \log(n)$ , where  $n$  is the number of segments. The PELT model with the applied manual penalty returned five changepoints with six homogeneous segments as shown in part (d). The average mean speed for all traces upstream of the first warning sign was 66.8 mph and the length of the stable condition was 226 which translated to about 2,000 feet or 22.2 seconds

The first changepoint was in reaction to the first work zone warning sign and DMS sign with a mean speed reduction of 1.5 mph. After the first changepoint, the mean speed was in a stable condition for about 3,500 feet and there was no reaction to the work zone's second warning sign, which is located about half a mile from the first<sup>t</sup> warning sign.

The next changepoint occurred when drivers reacted to the presence of a merge sign, a work zone speed limit sign (55 mph), the start of the taper, and a flashing arrow sign. The



cumulative effects of these safety measures caused a 3.5 mph mean speed reduction. The mean speed was in a stable condition for about 1,700 feet and almost 20 seconds.

The next identified changepoint was a mean speed reduction of 3.8 mph in reaction to a work zone speed limit sign, presence of channelization, and barriers on both sides of a single lane to direct the traffic to the other side of the roadway. The length of the stable condition following this changepoint was 150, which is a little over 1,300 feet or 15 seconds.

As drivers entered the work area, the mean speed had the highest decrease of all by 5.8 mph. The mean speed was reduced from the previous segment of 58 to 52.2 mph. After this reaction, the segment length in a stable condition was 239 which corresponds to 2,100 feet or about 24 seconds.

After traffic moved to the other side of the roadway with a head-to head traffic, the next changepoint was an increase of 1.5 mph in average mean speed. The length of segment after this changepoint was 169, which means the segment was in a stable condition for about 1,500 feet and lasted almost 17 seconds.

The overall reaction to the series of safety features in work zone one dropped the average mean speed from 66.8 mph upstream of the work zone's first warning sign to 52.2 mph at the work area. This was an average 14.6 mph mean speed reductions for all 62 speed traces.

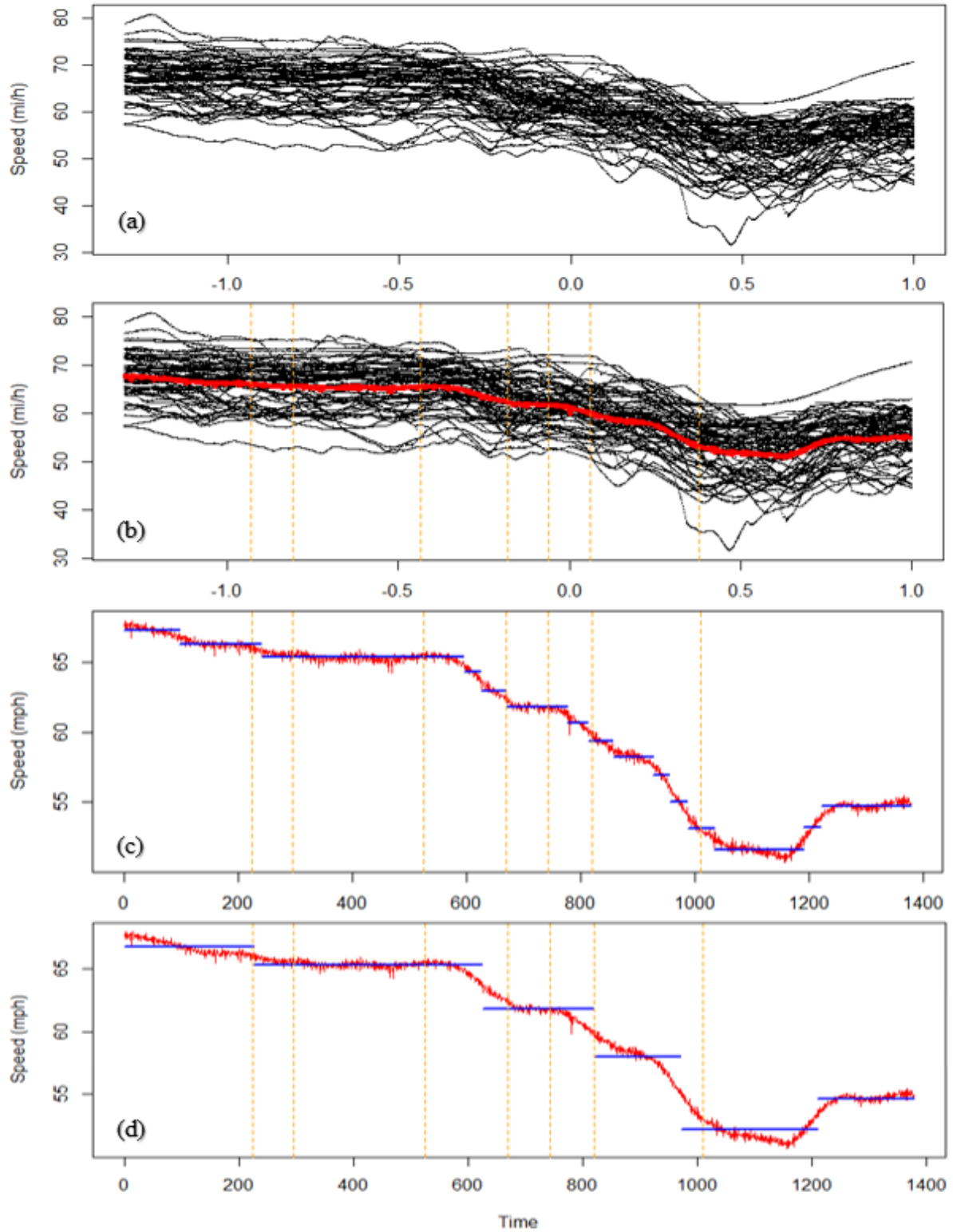

**Figure 3.6 Developing multiple changepoint model for overall drivers in work zone one**  
 (a) Plot of speed time series traces (b) Plot of calculated mean speed for time series traces (c)  
 Default detected multiple changepoints (d) Adjusted detected multiple changepoints

### 3.5.1.2 Male Drivers' Speed Profiles

The multiple changepoint model with the PELT algorithm was used to fit the 29 speed profiles of male drivers. Figure 3.7 presents male drivers' speed time series traces distribution. The speed distributions seem to be more toward the higher end of the spectrum. The variability between profiles seems to be lower relative to overall traces. About 70 percent of male drivers median speed is above 65 mph which is 10 mph above the work zone speed limit.

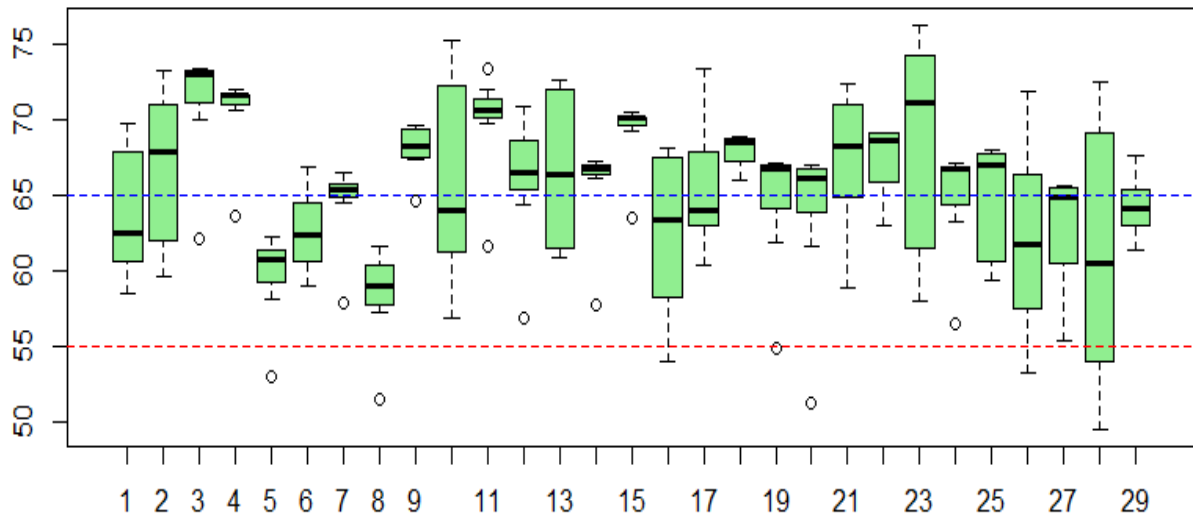

**Figure 3.7 Plot of speed time series distributions for male drivers**

Figure 3.8 parts (a) through (d) illustrates male drivers' speed time series plots. Part (a) shows the male drivers' raw speed time series traces. It can be seen from the plots of part (a) and part (b) that the majority of speed traces traveled at a high speed from upstream of the first warning sign up to the location where they encountered the merge sign, the work zone speed limit sign, the start of the taper, and the flashing arrow sign.

The mean speed of time series traces was fitted in the multiple changepoint model to estimate the maximum number of changepoints using a PELT algorithm as shown in part (c).

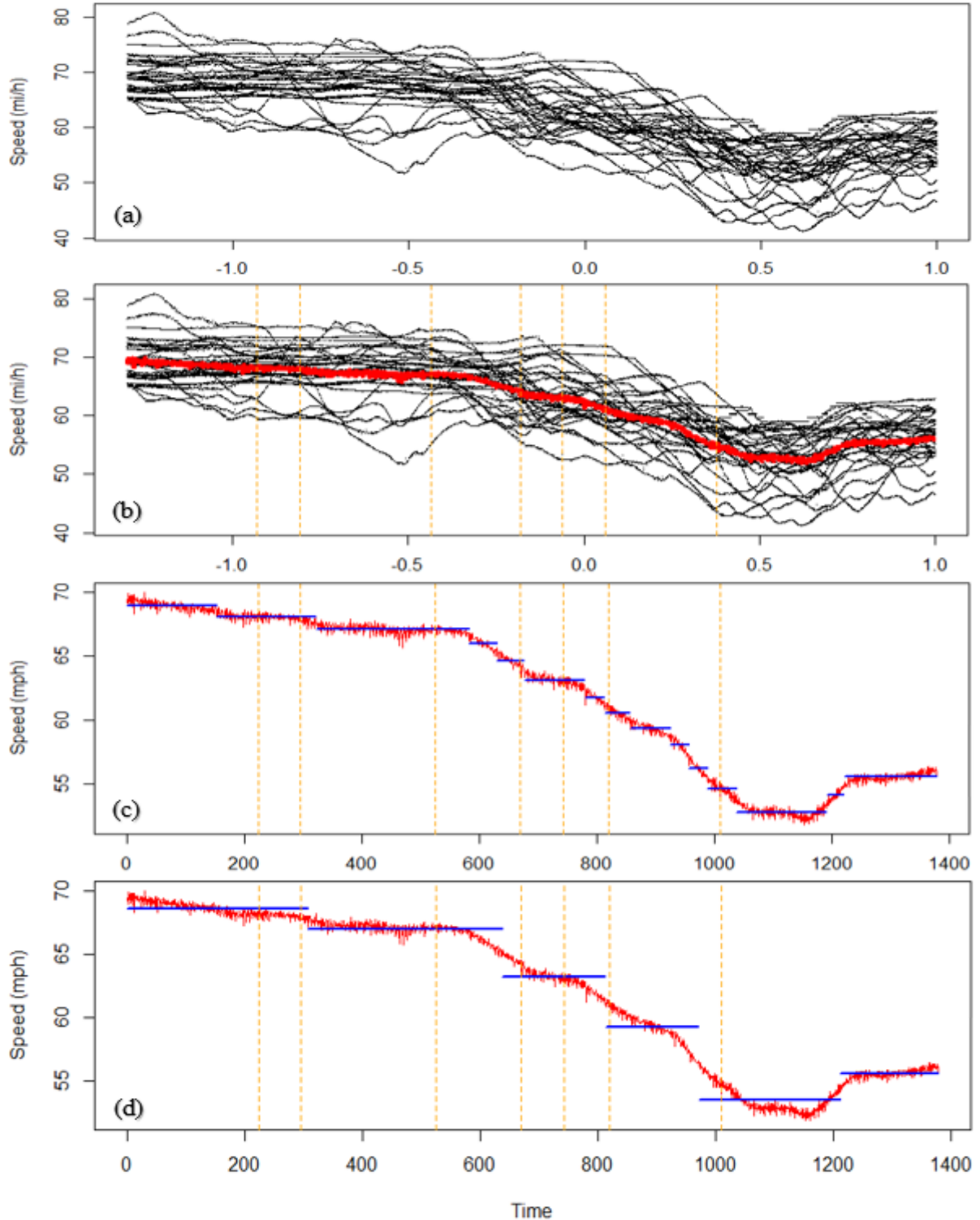

**Figure 3.8** Developing multiple changepoint model for male drivers in work zone one  
 (a) Plot of speed traces (b) Plot of calculated mean speed for time series traces (c) Default detected multiple changepoints (d) Adjusted detected multiple changepoints

The PELT changepoint model with a default penalty created 14 changepoints and provided 15 homogeneous segments. Similar to that for all traces, the model with the very small segment length and minimal mean speed changes between the segments is too sensitive and overfitted.

To adjust for overfitting, a manual penalty was increased to  $50 \log(n)$ . The same manual penalty as for all traces of  $35 \log(n)$  was returning six changepoints with one segment length was 75 which corresponds to 650 feet. This is a relatively short stable condition and suggested the model was still sensitive. The PELT model with the applied manual penalty returned five changepoints with six homogeneous segments as shown in part (d). The average mean speed for all traces upstream of the first warning sign was 68.5 mph and the length of the stable condition was 307 which was about 2,700 feet and lasted about 31 seconds.

The first changepoint occurred in reaction to the first work zone warning sign and a DMS sign with a mean speed reduction of 1.6 mph. After the first changepoint, the mean speed was in a stable condition for about 2,900 feet and there was no reaction to the work zone second warning sign.

The next changepoint occurred when drivers reacted to the presence of a left lane closed sign, a work zone speed limit sign, the start of the taper, and a flashing arrow sign. The cumulative effects of these safety measures caused a mean speed reduction from 66.9 mph to 63.2 mph, for a mean speed reduction of 3.7 mph. The mean speed was in a stable condition for about 1,550 feet or almost 16 seconds.

The next observed changepoint was a mean speed reduction of 4.0 mph when drivers reacted to a work zone speed limit sign, presence of channelization, and barriers on both side

of a single lane to direct the traffic to the other side of roadway. The length of stable condition following this changepoint was 158 which is about 1,400 feet and lasted almost 16 seconds.

As drivers approached the work area, the mean speed had the highest decrease by 5.7 mph. The mean speed was reduced from the previous segment of 59.2 mph to 53.5 mph. The length of the segment in a stable condition was 241, which corresponds to about 2,100 feet or about 24 seconds after drivers reacted to the work area's environment.

After traffic moved to the other side of the roadway with head-to-head traffic, the next changepoint was an increase of 2 mph in mean speed. The length of segment after this changepoint was about 1,500 feet and lasted almost 17 seconds.

The overall male drivers' reaction to the series of safety features in work zone one dropped the average mean speed from 68.5 mph upstream of the work zone first warning sign to 53.5 mph at the work area, a 15 mph mean speed reduction.

### ***3.5.1.3 Female Drivers' Speed Profiles***

There were 33 speed traces belonging to female drivers in work zone one. Figure 3.9 shows female drivers' speed profiles distribution, which seems more spread out between profiles. The median speed is lower compared to male drivers' traces. The majority of the speed is between 55 mph and 65 mph. The median speed of about 65 percent of traces were below 65 mph.

Figure 3.10 parts (a) through (d) illustrates female drivers' speed time series plots. The mean speed variation remained almost similar from upstream all the way to the upstream of the work area as shown in part (a) and (b), while variations observed to be slightly higher around the work area.

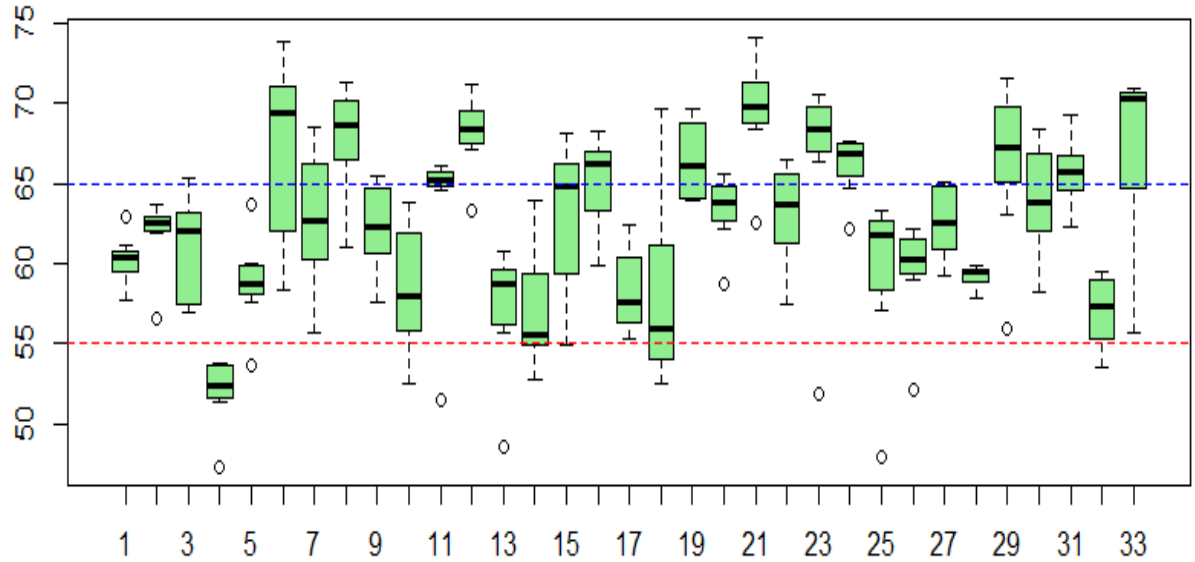
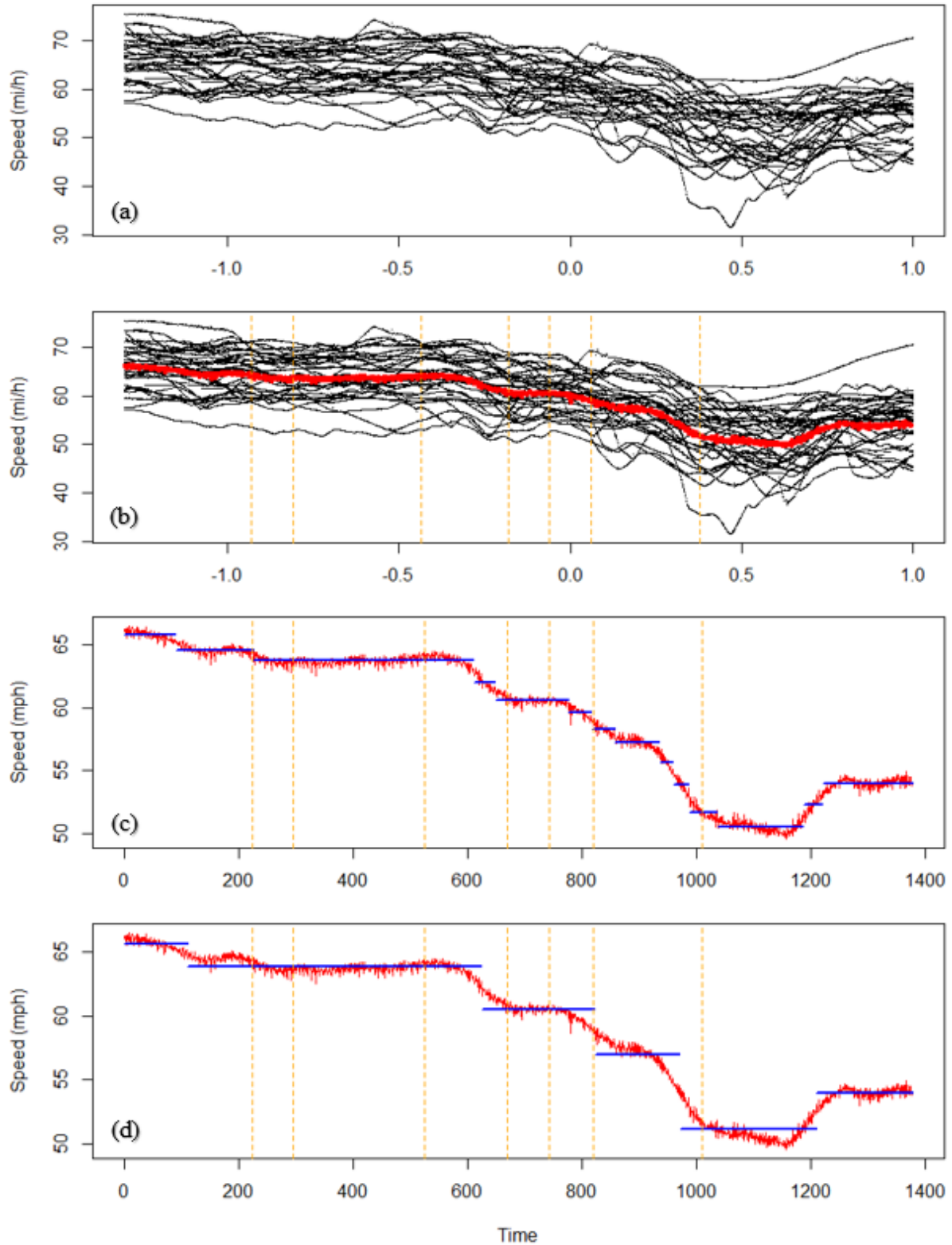

**Figure 3.9 Visual illustration of speed time series distribution for female drivers' traces**

The PELT changepoint model returned 13 changepoints which provided 14 homogenous segments as shown in part (c). Again, the model was too sensitive and overfitted.

The manual penalty was increased to  $35 \log(n)$ . The PELT model with an applied manual penalty returned 5 changepoints with 6 homogeneous segments as shown in part (d). The average mean speed for all traces upstream of the first warning sign was 65.6 mph and the length of stable condition was 111 which corresponded to less than 1,000 feet and duration of 11 seconds.

The first changepoint was observed when drivers reacted to the first work zone warning sign and the DMS sign with a mean speed reduction of 1.7 mph. After the first changepoint, the mean speed was in a stable condition for about 4,500 feet which lasted for 51 seconds. The speed trends slightly increased between the first and second warning signs which are one-half mile away from each other. There was no reaction to the work zone second warning sign.



**Figure 3.10** Developing multiple changepoint model for female drivers in work zone one  
 (a) Plot of speed time series traces (b) Plot of calculated mean speed for time series traces (c)  
 Default detected multiple changepoints (d) Adjusted detected multiple changepoints



The next changepoint was observed when drivers reacted to the presence of a merge sign, a work zone speed limit sign (55 mph), the start of the taper, and a flashing arrow sign. The collective effects of these safety measures dropped the average mean speed by 3.4 mph. The mean speed was in a stable condition for over 1,700 feet or almost 20 seconds.

The next identified changepoint was a mean speed reduction of 3.5 mph when drivers reacted to the work zone speed limit sign, presence of channelization, and barriers on both sides of a single lane. The length of stable condition following this changepoint was 148 which is almost 1,300 feet.

The average mean speed experienced a relatively large decrease of 5.9 mph as drivers entered the work area. The mean speed was reduced from of 57 mph to 51.1 mph. After drivers reacted to the work area conditions, the segment length in a stable condition was 239 which corresponds to 2,100 feet or about 24 seconds.

The final changepoint was an increase of 2.8 mph in the average mean speed after traffic was directed to the opposite side of the roadway with head-to-head traffic. The length of the segment after this changepoint was about 1,500 feet and lasted almost 17 seconds.

The overall female drivers' reactions to a series of safety features in work zone one dropped the average mean speed by 14.5 mph, from 65.6 mph upstream of the work zone first warning sign to 51.1 mph at the work area.

#### ***3.5.1.4 Closed Lane (Outside Lane) Drivers' Speed Profiles***

A model was fitted with 26 speed traces of drivers who drove in the closed or outside lane for the majority of time they traversed the work zone. Figure 3.11 shows closed lane drivers' speed time series distributions. The speed distributions from the boxplots reveal less

variation in between speed profiles for the majority of traces. Most of the median speeds are above 65 mph for drivers who were driving through the work zone in the closed lane.

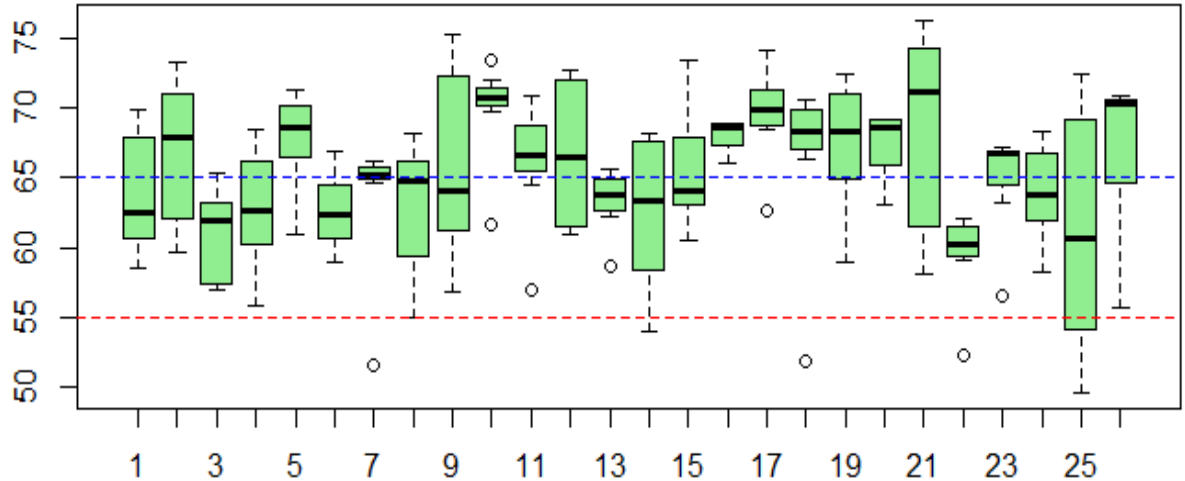

**Figure 3.11 Visual illustration of speed time series distribution for closed lane drivers**

Plots of closed lane drivers' speed time series traces are shown in Figure 3.12 parts (a) through (d). Traces in the plots of (a) and (b) show low variability in the speed between the traces from upstream of first work zone sign almost to the start of the work area. The higher speed variations in the work area were observed.

The PELT changepoint model returned 18 changepoints which provided 17 homogenous segments for the default penalty as shown in part (c). To overcome the issue of overfitting, a manual penalty was increased to  $35 \log(n)$ , but it contained a very short stable segment which stated the model was still sensitive. The manual penalty was increased to  $50 \log(n)$  when the model returned four changepoints with five homogeneous segments as shown in part (d). The average mean speed for all traces upstream of the first warning sign was 68.1 mph and the length of the stable condition was about 5,500 feet and lasted almost 62 seconds. There was no major reaction to the presence of the first work zone warning sign or the DMS.

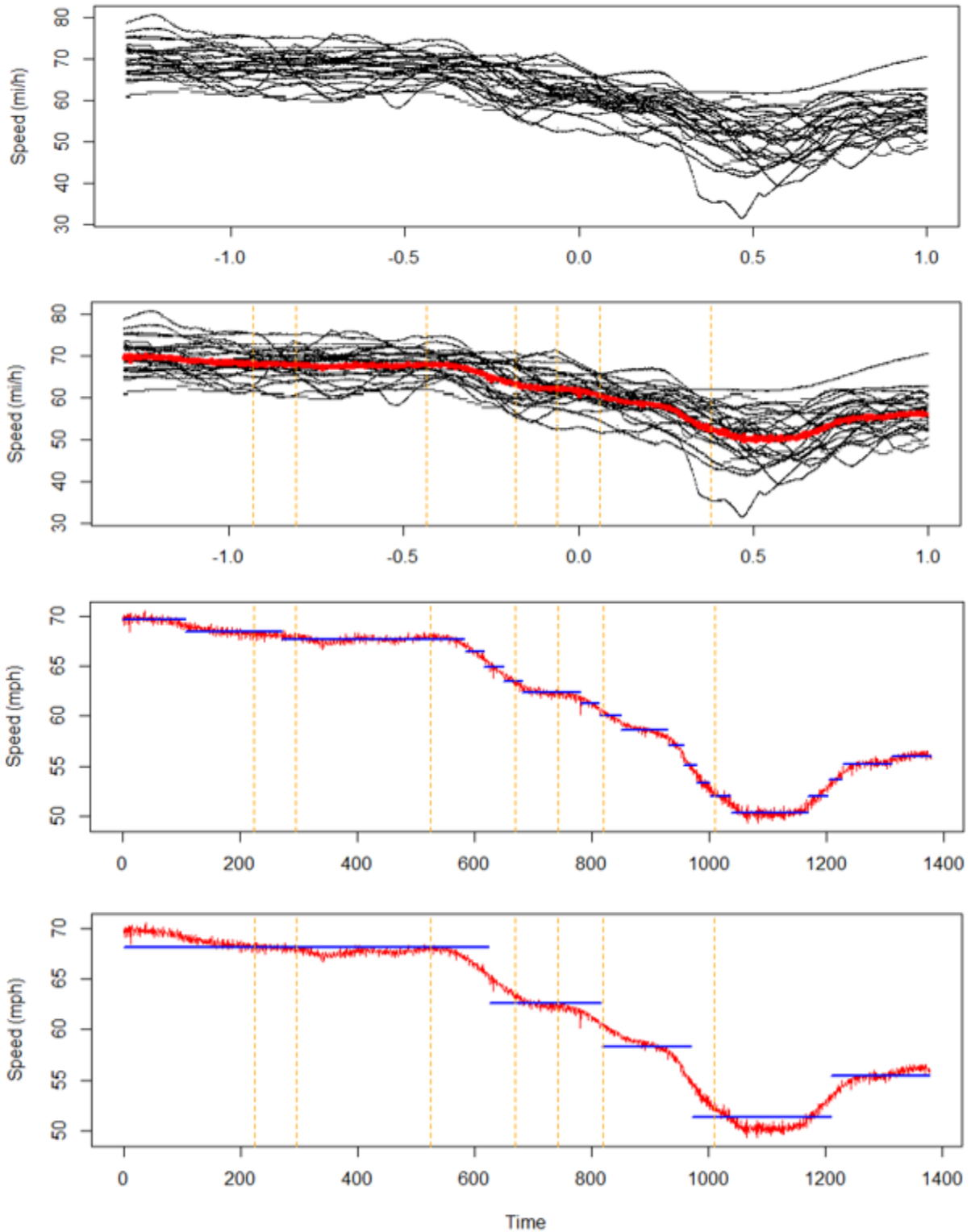

**Figure 3.12 Developing multiple changepoint model for closed lane drivers in work zone one**

- (a) Plot of speed time series traces (b) Plot of calculated mean speed for time series traces (c) Default detected multiple changepoints (d) Adjusted detected multiple changepoints

The first major changepoint occurred when drivers reacted to the presence of a left lane closed sign, a work zone speed limit sign, the start of the taper, and a flashing arrow sign. The cumulative effects of these safety measures dropped the average mean speed by 5.5 mph. The mean speed was in a stable condition for about 1,700 feet after this changepoint.

The next identified changepoint was a mean speed reduction of 4.3 mph when drivers reacted to the work zone speed limit sign, presence of channelization, and barriers on both side of a single lane to direct the traffic to the other side of roadway. The length of stable condition following this changepoint was about 1,400 feet.

The highest changepoint occurred when drivers approached the work area. The average mean speed dropped 6.9 mph from 58.3 to 51.4 mph. The length of the new segment was about 2,100 feet and lasted about 24 seconds.

The final changepoint was an increase of 4 mph in average mean speed after traffic was directed to the opposite side of the roadway with head-to-head traffic. The length of the segment after this changepoint was about 1,500 feet.

The overall closed lane drivers' reaction to a series of safety measures in work zone one reduced their speed by 16.7 mph from upstream of the work zone first warning sign to the work area.

### ***3.5.1.5 Open lane (Inside Lane) Drivers' Speed Profiles***

From the 62 traces, 36 were drivers who traversed the work zone through the open lane. Figure 3.13 presents open lane drivers speed time series traces' distribution. The speed distributions for open lane traces seem to have the highest variability between the traces. The average speed is relatively lower compared to all traces and is mainly distributed between 55 and 65 mph.

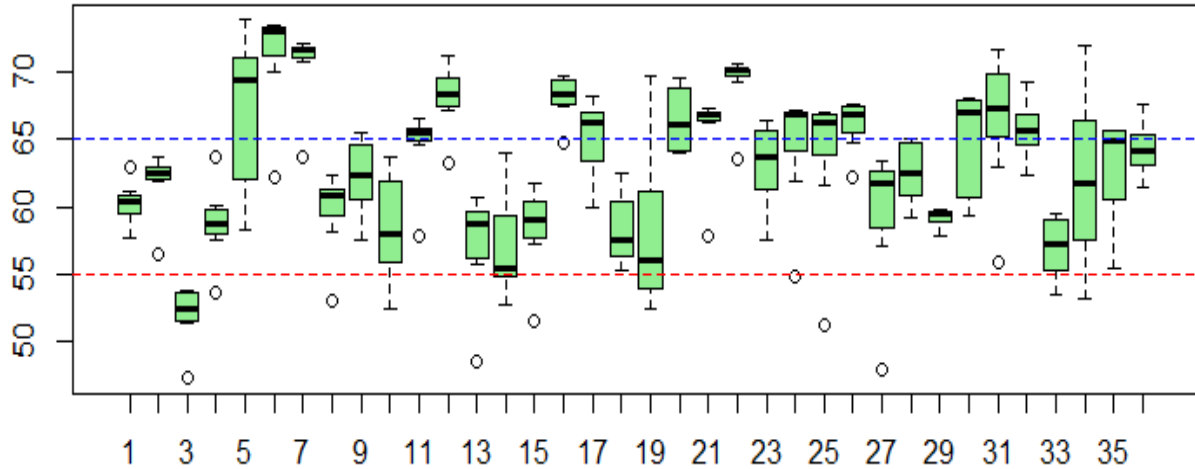
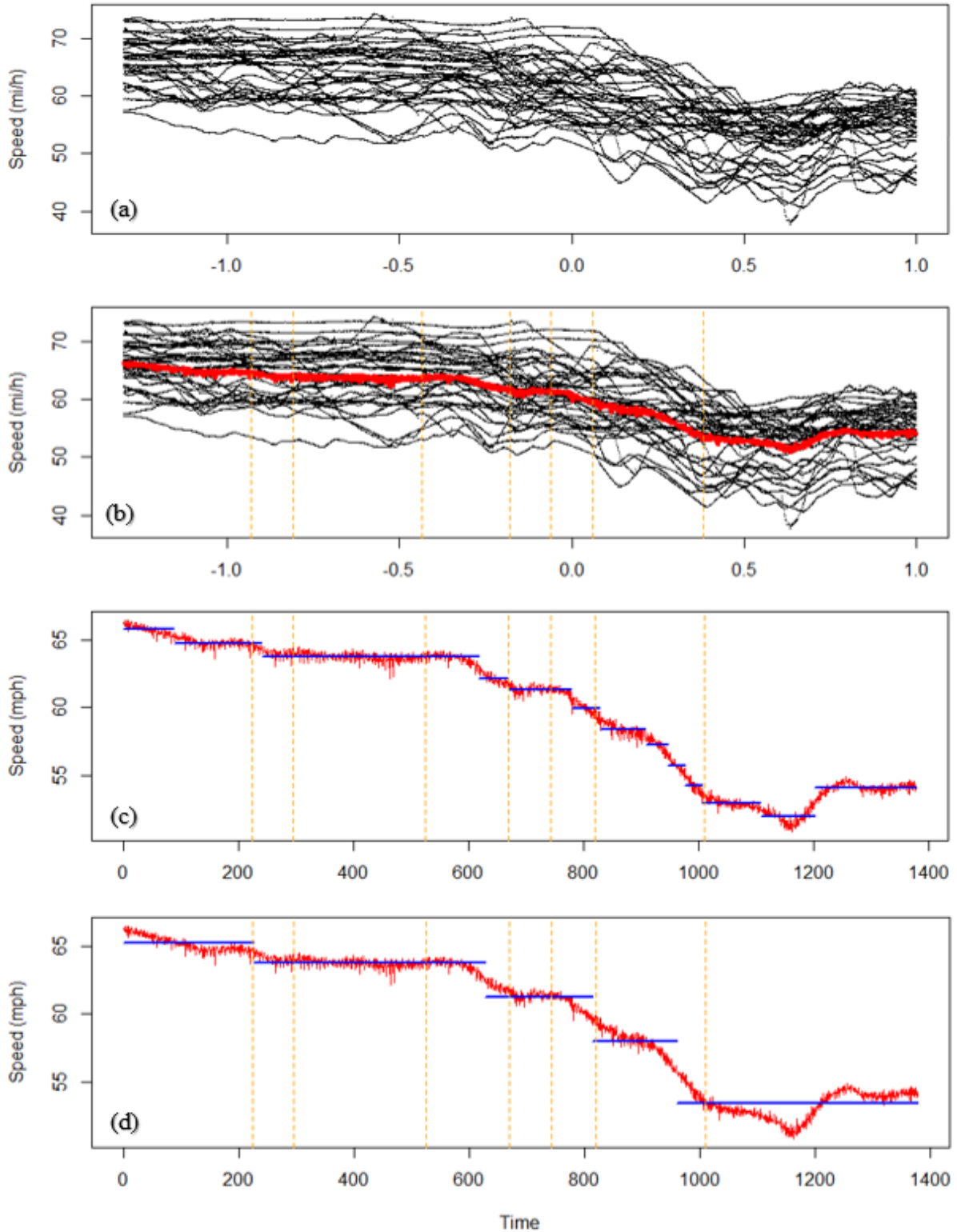

**Figure 3.13 Visual representation of speed time series distribution for open lane drivers**

Figure 3.14 parts (a) through (d) illustrates open lane speed time series plots. The speed traces revealed a constant speed from upstream of the first warning sign all the way to the start of the taper and the flashing arrow and a gradual speed reduction when approached channelization as shown in part (a) and (b). The speed variations remained almost constant in all different sections of work zone.

The PELT changepoint model returned 12 changepoints which provided 13 homogenous segments as shown in part (c). To overcome the issue of overfitting, a manual penalty was increased to  $35 \log(n)$ . The PELT model with applied manual penalty returned four changepoints with five homogeneous segments as shown in part (d). The average mean speed for all traces upstream of the first warning sign was 65.2 mph and the length of stable condition was about 2,000 feet and lasted almost 23 seconds.

The first changepoint occurred when drivers reacted to the first work zone warning sign and the DMS sign with a mean speed reduction of 1.4 mph. The mean speed changed to 63.7 mph and remained in the stable condition for over 3,500 feet.



**Figure 3.14 Developing multiple changepoint model for open lane drivers in work zone one**

(a) Plot of speed time series traces (b) Plot of calculated mean speed for time series traces (c) Default detected multiple changepoints (d) Adjusted detected multiple changepoints

The next changepoint was observed when drivers reacted to the presence of the lane merge sign, the work zone speed limit sign (55 mph), the start of the taper, and a flashing arrow sign. The collective effects of these safety measures dropped the average mean speed by only 2.5 mph. The amount of the mean speed drop was low relative to overall, male, and female traces. The mean speed was in a stable condition for over 1,600 feet after this changepoint.

The next identified changepoint was a mean speed reduction of 3.3 mph when drivers reacted to the work zone speed limit sign (55 mph), presence of channelization, and barriers on both side of a single lane directing traffic to the other side of the roadway. The length of the stable condition following this changepoint was about 1,300 feet.

The average mean speed dropped 4.5 mph as drivers entered the work area. The mean speed was reduced from the previous segment of 57.9 mph to 53.4 mph in the new segment.

The overall drivers' reaction to a series of safety features in work zone one with the left lane closure dropped the average mean speed from 65.2 mph upstream of the work zone first warning sign to 53.4 mph at the work area. This is an average 11.8 mph mean speed reductions for drivers drove in the open lane throughout the work zone.

#### ***3.5.1.6 Analysis Results Summary***

The summary results of the changepoints detection analysis for all five groups in work zone one are provided in Table 3.6. The highest upstream speed was for male drivers at 68.5 mph. This was about 5 and 6 percent higher than females and open lane drivers, respectively, and similar to that of closed lane drivers. The number of male drivers on open and closed lanes is almost identical at 14 and 15, respectively, while the number of female drivers on open lane was twice as many as who drove on closed lane

The first reaction was about 1.5 mph to the first work zone warning sign and the DMS, according to the model. The reaction was slightly higher for female drivers. The drivers in the closed lane had no reaction to the presence of first work zone warning sign and the DMS.

The first major reaction for closed lane drivers was when they approached the lane closure sign, the work zone speed limit sign, the start of the taper, and the flashing arrow. The combined effect of these safety features was a reduction of 5.5 mph, which corresponds to over 8 percent speed reduction compared to upstream speed. The reaction to these series of safety measure was lowest for open lane drivers with 2.5 mph speed reduction and slightly higher for male drivers at 3.7 mph compared to 3.4 mph for female drivers.

**Table 3.6 Summary of multiple changepoints detected in work zone 1**

Model Input Data Group	Multiple Changepoints PELT Model Results									
	Mean Speed (mph) Upstream	Change in Mean Speed (mph)	Mean Speed (mph) Reaction to first WZ sign and DMS	Change in Mean Speed (mph)	Mean Speed (mph) Reaction to Lane closure sign, WZ posted speed sign, start of taper and flashing arrow	Change in Mean Speed (mph)	Mean Speed (mph) Reaction to WZ posted speed sign & channelization	Change in Mean Speed (mph)	Mean Speed (mph) Reaction to start of work area	Overall Mean Speed Reduction (mph)
All (62 Traces)	66.8	-1.5	65.3	-3.5	61.8	-3.8	58.0	-5.8	52.2	-14.6
Male drivers (29 Traces)	68.5	-1.6	66.9	-3.7	63.2	-4.0	59.2	-5.7	53.5	-15.0
Female drivers (33 Traces)	65.6	-1.7	63.9	-3.4	60.5	-3.5	57.0	-5.9	51.1	-14.5
Closed lane (26 Traces)	68.1	0.0	68.1	-5.5	62.6	-4.3	58.3	-6.9	51.4	-16.7
Open lane (36 Traces)	65.2	-1.4	63.7	-2.5	61.2	-3.3	57.9	-4.5	53.4	-11.8

After drivers reacted to the taper point and the flashing arrow, they approached another posted speed sign of 55 mph and channelization by barrels, jersey barriers, and a



series of chevrons. The channelization was set up to direct the traffic to the opposite side of the roadway for head-to-head traffic since one side of the road was completely closed. The effect of this situation forced the drivers to reduce their speed by 3.8 mph for all drivers. The reduction was even higher for closed lane and male drivers with 4.3 and 4 mph, respectively. The open lane drivers once again had the lowest reaction to this situation and reduced their speed by 3.3 mph.

The final change point detected at the start of work area where presence of equipment and occasionally workers were observed. The reaction to this involved the highest speed reduction for all categories in the analysis. The mean speed for the closed lane drivers decreased by 6.9 mph from 58.3 mph to 51.4 mph, a reduction of about 12 percent in mean speed. Female, overall, and male drivers had pretty similar reactions to this situation by reducing their mean speed by about 5.8 mph, while open lane drivers reduced their speed by 4.5 mph.

The overall speed reduction was highest for closed lane drivers by 16.7 mph and lowest for open lane drivers by 11.8 mph. It was similar for overall and female drivers by about 14.5 mph and slightly higher for male drivers with a 15 mph speed reduction in the work zone one.

For work zone two and the remaining work zones in this research, the main findings of each model will be discussed. All the steps in developing the final change point models along with the associated plots were discussed comprehensively in this section. The intermediate steps and plots will be eliminated due to the extent of the research and the fact that the process was already explained in great detail.

### 3.5.2 Left Lane Closure with a DMS after Lane Merge Sign

Work zone two involved a left lane closure on a 4-lane divided rural highway. There were 42 speed time series traces in this work zone. The distributions of speed traces are shown in Appendix 3. The majority of drivers' speed is between of roadway speed of 65 mph and the work zone speed of 55 mph. A series of safety measures applied in this work zone included a left merge sign, a DMS, a work zone speed limit sign, taper point, and a flashing arrow. In this work zone a DMS was located after the left lane closed sign at about 1,400 feet upstream of the start of the taper. The speed profiles selected in this work zone starts about 500 feet upstream of the first observed sign, which is lane closed sign, and continued all the way to the work area, as shown in Figure 3.15.

Speed time series traces along with computed mean for overall (a), male drivers (b), female drivers (c), closed lane (d), and open lane (e) drivers are shown in the left panel of Figures 3.15 through 3.22 for work zones two to nine, respectively. The time series data for all five groups fitted in the multiple changepoints model and the PELT algorithm was applied to detect the optimal number and locations of the changepoints. The corresponding results of the multiple changepoint models are shown in the right panel of in Figures 3.15 to 3.22.

There were three changepoints detected in the models for all 5 groups in this work zone. There was an acceptable period of stability observed after each changepoint in models for all groups. The upstream mean speed ranged from 59.2 to 63.8 mph. The mean speed data reveals male drivers started to react to the safety measures earlier than all other groups about 100 feet before the lane closed sign. The closed lane drivers started to react at about 100 feet after the lane closed sign. The reactions for all, female, and open lane drivers occurred between 200 to 300 feet before the DMS sign.

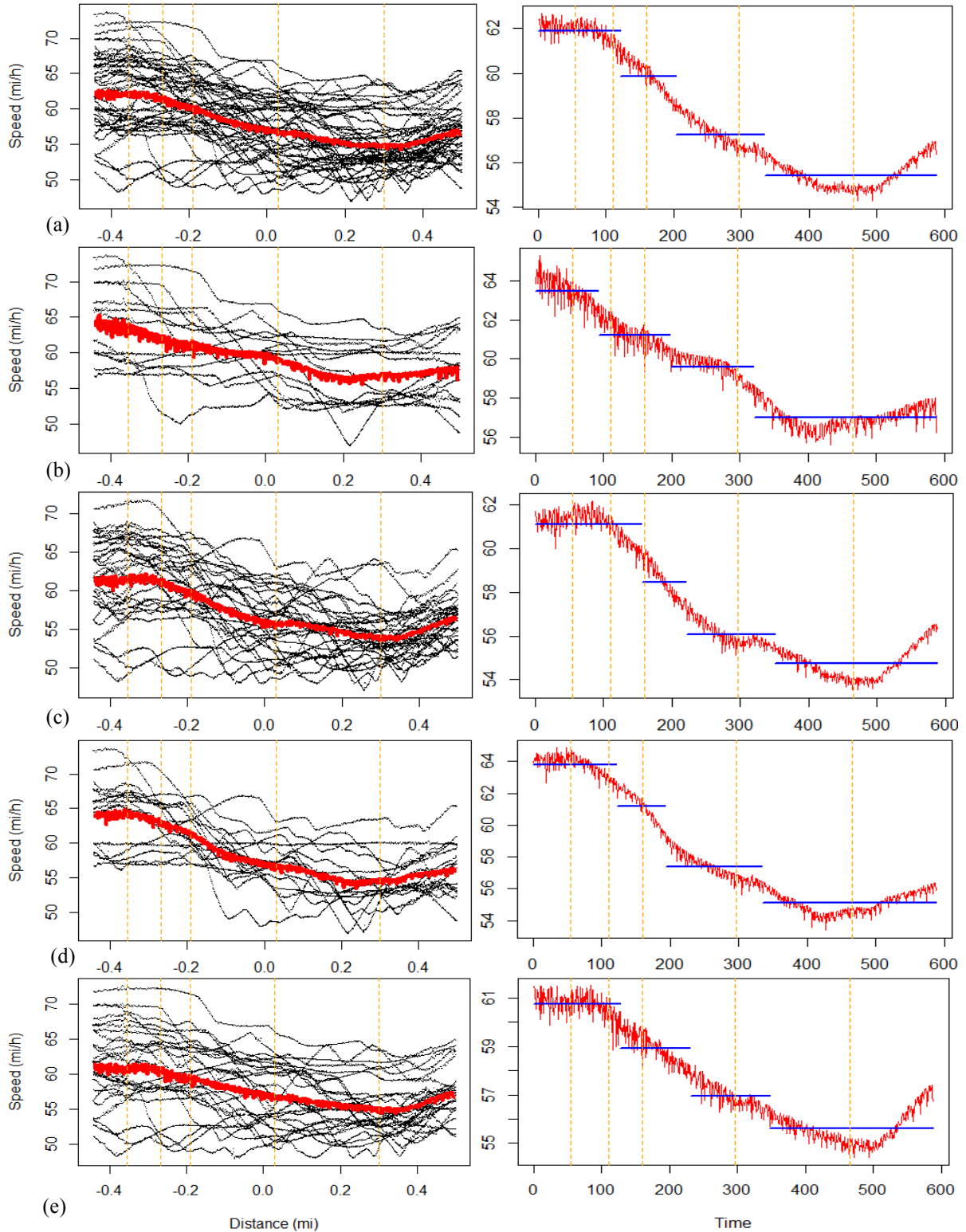

**Figure 3.15 Developing multiple changepoint models for work zone two**

Left panel. Plot of mean speed of time series traces for overall traces (a), male drivers (b), female drivers (c), closed lane traces (d), and open lane traces (e). Right panel. Adjusted detected multiple changepoints for the corresponding categories to the left

The mean speed of open lane and male drivers at the work area were 58.5mph and 57 mph, respectively. The female drivers had the lowest mean speed at the work area with 54.7 mph. The mean speed of all and closed lane drivers were close to the work zone speed limit.

### 3.5.2.1 Analysis Results Summary

The results of multiple changepoint detection models for all 5 groups in the work zone with a left lane closure and a DMS located at about 1,400 feet upstream of the taper are summarized in Table 3.7.

**Table 3.7 Summary of multiple changepoints detected in work zone 2**

Model Input Data	Multiple Changepoints PELT Model Results							
	Mean Speed (mph) Upstream	Change in Mean Speed (mph)	Mean Speed (mph) Reaction to DMS & WZ Speed limit sign	Change in Mean Speed (mph)	Mean Speed (mph) Reaction to start of taper & flashing arrow	Change in Mean Speed (mph)	Mean Speed (mph) Reaction to work area	Overall Mean Speed Reduction (mph)
All (42 Traces)	61.9	-2.1	59.8	-2.5	57.3	-1.9	55.4	-6.5
Male drivers (13 Traces)	63.5	-2.3	61.2	-1.6	59.6	-2.6	57.0	-6.5
Female drivers (29 Traces)	61.1	-2.6	58.5	-2.4	56.1	-1.4	54.7	-6.4
Closed lane (16 Traces)	63.8	-2.6	61.2	-3.8	57.4	-2.3	55.1	-8.7
Open lane (26 Traces)	59.2	2.8	62.0	-1.3	60.7	-2.2	58.5	-0.7

The mean speed at the upstream of the first sign was relatively low for all 5 groups and ranged from 59.2 mph for open lane drivers to 63.8 mph for closed lane drivers. A changepoint was detected in response to the DMS and work zone speed limit sign. The largest reaction was observed for open lane drivers with a 2.8 mph mean speed reduction. The range of the mean speed reduction was between 2.1 and 2.8 mph. According to the next detected changepoint in the model, which was a reaction to the start of the taper and flashing

arrow, closed lane and the open lane drivers had the highest and lowest mean speed reductions by 3.8 mph and 1.3 mph, respectively.

The final changepoint was detected as drivers approached the work area. The male drivers' mean speed was decreased by 2.6 mph from 59.6 to 57 mph. The female drivers mean speed was reduced by 1.4 mph. Surprisingly, the open lane drivers had the highest mean speed of 58.5 mph after reacting to the work area and reducing their speed by 2.2 mph.

The overall speed reduction was only 0.7 mph for open lane drivers compared to 8.7 mph for closed lane drivers. Male and female drivers have similar overall speed reductions by about 6.5 mph, but had different upstream speeds resulting in male drivers' higher mean speed at the work area.

### **3.5.3 Left Lane Closure with a DSFS after Work Zone First Warning Sign**

There were 76 speed time series traces in work zone three for the vehicles traveled through a left lane closed work zone with a DSFS on a rural 4-lane divided highway.

The distributions of speed traces are shown in Appendix 3. The speed distributions for the majority of the drivers were above the roadway speed limit of 55 mph throughout the work zone. A series of safety measures applied in this work zone included first work zone warning sign with an attached advisory speed plate of 50 mph, a DSFS, a second work zone warning sign with an attached advisory speed plate of 45 mph, a left lane closed sign with an attached advisory speed plate of 45 mph, taper point, a flashing arrow, and a work zone speed limit sign. The DSFS was located at about 500 feet after the first work zone warning sign and about 2,200 feet upstream of the taper. The speed time series data for this work zone was collected at one-quarter mile upstream of the first warning sign which was located at 0.5 miles upstream of the taper.

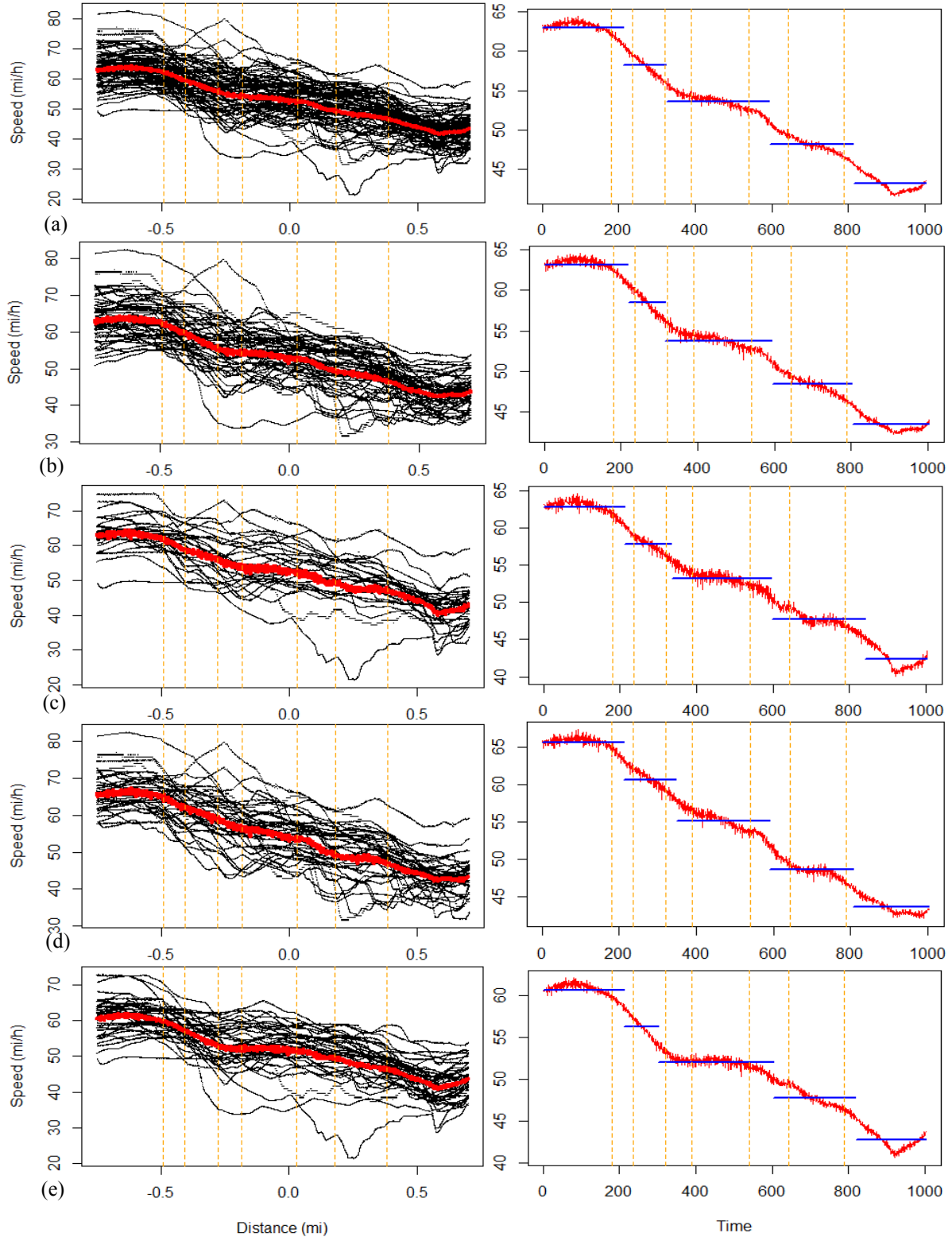

**Figure 3.16 Developing multiple changepoint models for work zone three**  
 Left panel. Plot of mean speed of time series traces for overall traces (a), male drivers (b), female drivers (c), closed lane traces (d), and open lane traces (e). Right panel. Adjusted detected multiple changepoints for the corresponding categories to the left

Models detected 4 changepoints in work zone three in reaction to the applied safety countermeasures. The mean speed upstream of the first work zone warning sign ranged from 60.7 mph for open lane drivers to 65.6 mph for the closed lane drivers. This reveals the upstream speed was about 15% higher than roadway speed limit of 55 mph among all groups. There was a rapid speed reduction in reaction to the first work zone warning sign and the DSFS, which was located about 500 feet after the first warning sign and was visible from 100 feet upstream of the first sign. The plots revealed the major reaction was to the DSFS and there was a gradual speed reduction after drivers approached the taper, flashing arrow, and channelization.

The reaction to the work area was a reduction of mean speed by about 5 mph for all groups. The mean speed of all five groups reduced to lower than work zone speed limit of 45mph after this changepoint was detected.

### ***3.5.3.1 Analysis Results Summary***

The results of the multiple changepoint detection model for all groups in the work zone with a left lane closure and DSFS located at about 2,200 feet upstream of the taper are summarized in Table 3.8. The first changepoint was a relatively large speed reduction for all five groups in reaction to the DSFS. The mean speed reduction ranged from 4.4 to 4.9 mph.

The next major changepoint was detected in response to the second work zone warning sign and the left lane merge sign with the attached advisory speed plate of 45 mph on both signs. Closed lane drivers' mean speed was reduced by 5.6 mph as the highest reaction, and open lane drivers had 4.3 mph speed reduction for the lowest reaction in the range. The changepoint model plots revealed a period of relatively short stability after reacting to the DSFS for the segment created by the changepoint. The short stability is more

prevalent for male drivers and open lane groups. This means drivers were still processing the DSFS and continued to adjust their speed to work zone speed of 45 mph. This is suggesting the second detected changepoint in the model created a very short segment and the actual speed reduction effect by the DSFS can be measured in the next segment with a higher stability length. If the second changepoint is combined with the next changepoint, which had a high segment length, the effect of DSFS reduced the mean speed by as much as 10.5 mph for closed lane drivers and as low as 8.7 mph for open lane drivers. There was a 16 and 14.3% mean speed reduction for closed lane and open lane drivers, respectively.

**Table 3.8 Summary of multiple changepoints detected in work zone 3**

Model Input Data group	Multiple Changepoints PELT Model Results									
	Mean Speed (mph) Upstream	Change in Mean Speed (mph)	Mean Speed (mph) Reaction to 1st WZ warning sign and DSFS	Change in Mean Speed (mph)	Mean Speed (mph) Reaction to 2nd WZ warning sign and left Lane closure sign	Change in Mean Speed (mph)	Mean Speed (mph) Reaction to start of taper, flashing arrow, and channelization	Change in Mean Speed (mph)	Mean Speed (mph) Reaction to start of work area	Overall Mean Speed Reduction (mph)
All (76 Traces)	63.0	-4.7	58.3	-4.7	53.6	-5.4	48.2	-5.0	43.2	-19.8
Male drivers (49 Traces)	63.1	-4.6	58.5	-4.7	53.8	-5.3	48.5	-5.0	43.5	-19.6
Female drivers (27 Traces)	62.8	-4.9	57.9	-4.7	53.2	-5.4	47.8	-5.4	42.4	-20.4
Closed lane (37 Traces)	65.6	-4.9	60.7	-5.6	55.1	-6.4	48.7	-5.1	43.6	-22.0
Open lane (39 Traces)	60.7	-4.4	56.3	-4.3	52.0	-4.2	47.8	-5.0	42.8	-17.9

The next changepoint was observed at the start of the taper, flashing arrow, and channelization with a mean speed reduction of 6.4 mph for closed lane and 4.2 mph for open lane drivers. The mean speed reduction for overall, male, and female drivers was around 5.4 mph. The final changepoint was detected in reaction to the work area. The mean speed



reduction ranged from 5.1 to 5.4 mph. The highest reduction was for female drivers, who reduced their speed to 42.4 mph in the work area.

The overall speed reduction was relatively high among all five groups, which suggests the safety measures applied in this work zone were successful to get driver's attention to reduce their speed to the desired work zone speed. The highest reduction was for the closed lane drivers with a mean speed reduction of 22 mph and the lowest speed reduction was for the open lane drivers by 17.9 mph. Female drivers' mean speed was reduced from 62.8 to 42.4 mph, a 20.4 mph speed reduction. Male drivers' mean speed was reduced by 19.6 mph.

#### **3.5.4 Left Lane Closure on Multi-lane Divided Rural Highway**

The analysis in this section is on work zone 4 which was over a multi-lane divided rural highway with the left lane closure. There were 55 speed time series traces of drivers traveled through this work zone. The roadway speed limit was 70 mph and there was no speed reduction for this work zone. The distributions of speed traces are shown in Appendix 3. The speed distributions reveal the majority of speeds hovering around 70 mph. The median speeds are very close to 70 mph. A series of safety features applied in this work zone included a first work zone warning sign, a left lane closed sign, taper point, and a flashing arrow.

The model detected two changepoints for all five groups after the correction for overfitting. The average mean speed of overall group is around 70 mph upstream of the first work zone sign which was similar to the roadway speed limit. There was no reaction to the first work zone warning sign and the left lane closed sign.

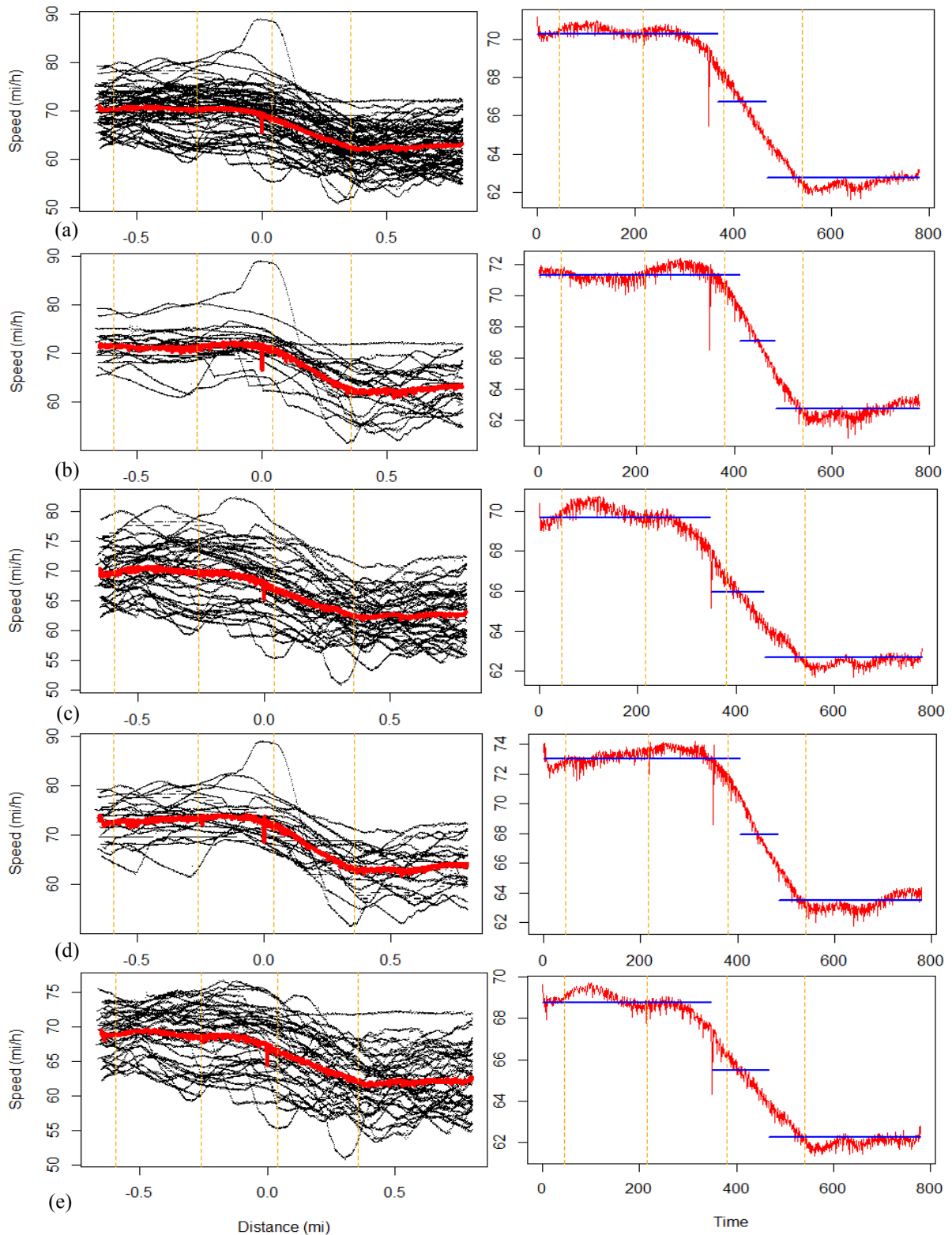

**Figure 3.17 Developing multiple changepoint models for work zone four**  
 Left panel. Plot of mean speed of time series traces for overall traces (a), male drivers (b), female drivers (c), closed lane traces (d), and open lane traces (e). Right panel. Adjusted detected multiple changepoints for the corresponding categories to the left

Drivers started to react to the work zone gradually at about 700 feet upstream of the taper and there was a large low spike in the mean speed at the vicinity of the taper area. The reaction started earlier at about 1000 feet upstream of the taper for female and open lane drivers. However, male and close lane drivers started to react closer to the work area at about 400 feet upstream of the taper. The final changepoint occurred at the work area. The average mean speed was in the range of 62.2 to 63.5 mph after drivers reacted to the start of the work area, which was about 6.5 to 7.8 mph lower than the speed limit.

#### 3.5.4.1 Analysis Results Summary

The results of multiple changepoint detection models utilizing the PELT algorithm for all five groups in work zone four with left lane closure on a multi-lane divided highway are summarized in Table 3.9. There was no reaction to the first work zone warning sign and a negligible reaction to the left lane closed sign.

**Table 3.9 Summary of multiple changepoints detected in work zone 4**

Model Input Data Group	Multiple Changepoints PELT Model Results							
	Mean Speed (mph) Upstream	Change in Mean Speed (mph)	Mean Speed (mph) Reaction to left lane closed sign	Change in Mean Speed (mph)	Mean Speed (mph) Reaction to start of taper & flashing arrow	Change in Mean Speed (mph)	Mean Speed (mph) Reaction to work area	Overall Mean Speed Reduction (mph)
All (55 Traces)	70.3	0.0	70.3	-3.6	66.7	-4.0	62.7	-7.6
Male drivers (21 Traces)	71.3	0.0	71.3	-4.2	67.1	-4.4	62.7	-8.6
Female drivers (34 Traces)	70.3	-0.7	69.6	-3.6	66.0	-3.5	62.5	-7.8
Closed lane (20 Traces)	73.0	0.0	73.0	-5.1	67.9	-4.4	63.5	-9.5
Open lane (35 Traces)	69.2	-0.6	68.6	-3.1	65.5	-3.3	62.2	-7.0

The first major detected changepoint was in reaction to the start of the taper and flashing arrow with a mean speed reduction ranging between 3.1 and 5.1 mph. Male drivers speed was reduced by 4.2 mph compared to 3.6 for female drivers. The final major changepoint was detected at the work area. Again, male drivers had a higher mean speed reduction than female drivers at 4.4 mph versus 3.5 mph. The speed reduction for closed lane and open lane groups were 4.4 mph and 3.3 mph, respectively.

The overall mean speed reduction was relatively high due to the fact that there was no work zone speed limit. The mean speed reduction from upstream through the work area ranged between 7 and 9.5 mph. The drivers in the closed lane reduced their speed by 9.5 mph. Male drivers' mean speed reduction was 8.6 mph compared to 7.8 mph for female drivers. These results show drivers react to the risks mainly based on their perception. Although there was no speed reduction, drivers reduced their speed in reaction to the work zone conditions by as much as 9.5 mph.

### **3.5.5 Right Lane Closure with a DSFS after Work Zone First Warning Sign**

In this section we changed the focus from the previous four work zones, which had left lane closures with different characteristics, to work zone five with a right lane closure. The PELT algorithm was applied to the 68 speed time series traces for vehicles traveled through this work zone with a DSFS on a rural 4-lane divided highway. A series of safety measures applied in this work zone including first warning sign with an attached 50 mph advisory plate, a DSFS, a second warning sign with an attached 45 mph advisory plate, a right lane closed sign with an attached 45 mph advisory plate, taper location, a flashing arrow, and a work zone speed limit sign.

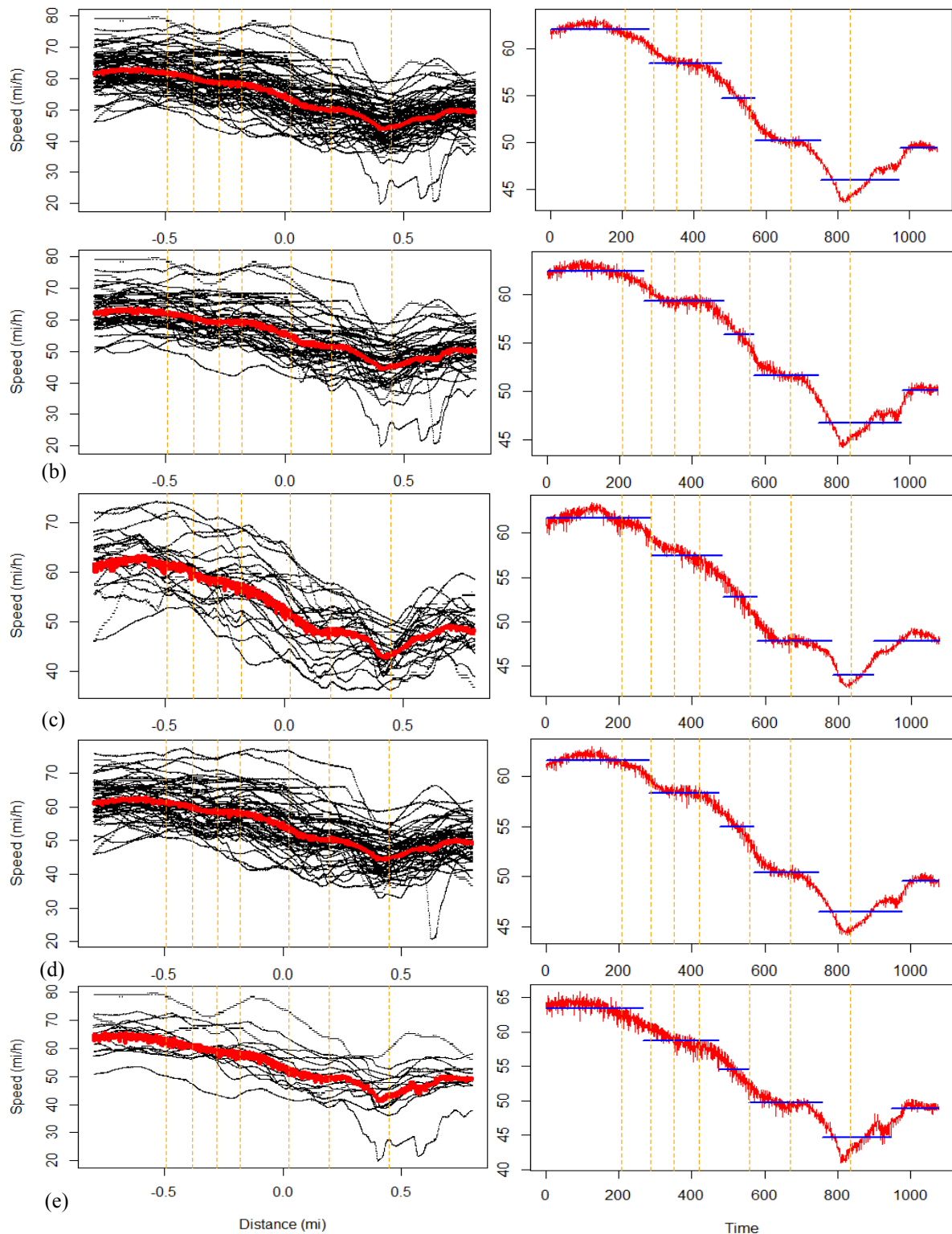

**Figure 3.18 Developing multiple changepoint models for work zone five**  
 Left panel. Plot of mean speed of time series traces for overall traces (a), male drivers (b), female drivers (c), closed lane traces (d), and open lane traces (e). Right panel. Adjusted detected multiple changepoints for the corresponding categories to the left

There were five main changepoints detected by the PELT model after the adjustment for overfitting for all five groups in the study. The mean speed upstream of the first warning sign was ranged from 61.6 to 63.4 mph. Open lane drivers were at the higher end with 63.4 mph and female drivers, with a mean speed of 61.7 mph, were at the lower end of the range. According to the mean speed plots for all five groups, drivers started to gradually react to the first warning sign and more rapidly to the DSFS. The reaction to the DSFS was higher and more sudden for female drivers and closed (inside) lane drivers. Data indicate 18 out of 23 female and 34 out of 53 male drivers' traces occurred on the inside (closed) lane.

Male drivers, who had more than twice traces as the female drivers in this work zone, maintained their speed after reacting to the DSFS for about 1,000 feet when they reacted sharply to the right lane closed sign at about 1,000 feet upstream of the taper. Female drivers' reaction was more gradual toward the taper area after 4.7 mph speed reduction due to the DSFS.

Female drivers also had the highest speed reduction at the start of the taper when they speed reduced by 9.4% from the previous stable segment, compared to 7.8% for male drivers. There was a sharp speed reduction in reaction to the work area for all groups, however, it was more prominent for male and outside (closed) lane drivers.

#### ***3.5.5.1 Analysis Results Summary***

The summary results of all five groups in the analysis for work zone five are provided in Table 3.10. The open (outside) lane drivers traveled at 63.4 mph upstream of this work zone, 15% higher than the 55 mph roadway speed limit and about 34% higher than the 45 mph work zone speed limit. Table 3.9 also shows all other groups were speeding in this work zone. All five groups had relatively substantial reactions to the first warning sign and the

DSFS ranging from 3.4 to 4.7 mph. Even the reduction from 63.4 to 57.4 mph among the different groups didn't bring the mean speed down to the roadway speed limit, although the goal was to bring the speed down to the work zone speed limit of 45 mph.

Female drivers had the highest speed reduction of 4.3 mph (7.2%) when reacted to the first warning sign and the DSFS. The reaction was lowest for the closed lane and male drivers with 3.3 mph (5.5%) and 3.1 mph (5.1%), respectively. The start of the taper, flashing arrow, and channelization speed reduction measures were successful to lower all groups' speed by maximum of 4.9 mph, from a range of 55.8 to 47.8 mph. The mean speed for all five groups were in the range of 47.8 mph to 51.6 mph. There was a 9.8% speed reduction for female drivers compared to 7.8% for female drivers.

**Table 3.10 Summary of multiple changepoints detected in work zone 5**

Model Input Data Group	Multiple Changepoints PELT Model Results									
	Mean Speed (mph) Upstream	Change in Mean Speed (mph)	Mean Speed (mph) Reaction to 1st WZ warning sign and DSFS	Change in Mean Speed (mph)	Mean Speed (mph) Reaction to 2nd WZ warning sign and right Lane closure sign	Change in Mean Speed (mph)	Mean Speed (mph) Reaction to start of taper and flashing arrow	Change in Mean Speed (mph)	Mean Speed (mph) Reaction to start of work area	Overall Mean Speed Reduction (mph)
All (68 Traces)	62.0	-3.5	58.5	-3.8	54.7	-4.5	50.2	-4.1	46.1	-15.9
Male drivers (44 Traces)	62.4	-3.1	59.3	-3.5	55.8	-4.2	51.6	-4.9	46.7	-15.7
Female drivers (23 Traces)	61.7	-4.3	57.4	-4.7	52.7	-4.9	47.8	-3.8	44.0	-17.7
Closed lane (53 Traces)	61.6	-3.3	58.3	-3.4	54.9	-4.5	50.4	-4.0	46.4	-15.2
Open lane (15 Traces)	63.4	-4.6	58.8	-4.2	54.6	-4.9	49.7	-5.0	44.7	-18.7

The effect of the work area with the presence of equipment and workers was successful to be the last option to get drivers' attention to reduce their speed to the posted

work zone speed of 45 mph, which worked for all groups travelling through this work zone. The mean speed produced a relatively large changepoint at the work area with a range of 3.8 to 5 mph speed reduction. The mean speed was reduced from a maximum of 51.6 mph for the previous segment to a minimum of 44 mph in the new segment among all groups, this is about 15% reduction in mean speed between the last two segments.

The overall reduction in mean speed from upstream through the work area was up to 34.6% for open lane drivers. The lowest reduction was for male and all drivers of about 29%. female drivers had a relatively high reduction of about 34%.

### **3.5.6 Left Shoulder Closure**

Work zone six demonstrates left shoulder closure on a 4-lane divided rural highway. There were 40 speed time series profiles in this work zone. The distributions of speed traces are shown in Appendix 3. The speed time series distribution reveals the vast majority of drivers driving at a speed higher than the roadway speed of 55 mph. There are a small proportion of female drivers driving below the speed limit. There was no required speed reduction in this work zone. A series of safety features applied in this work zone included a work zone first warning sign about 1,500 feet upstream of shoulder closure and shoulder closed sign.

The PELT model results detected two major changepoints for all groups but female drivers whose model only returned one changepoint. The mean speed upstream of the first work zone warning sign ranged from 57.6 mph for inside lane to 64.4 mph for outside lane drivers. Male drivers' speed at this location was 60.8 mph compared to 57.8 for female drivers. The first major changepoint was observed in response to the first work zone warning sign for all groups but female drivers.



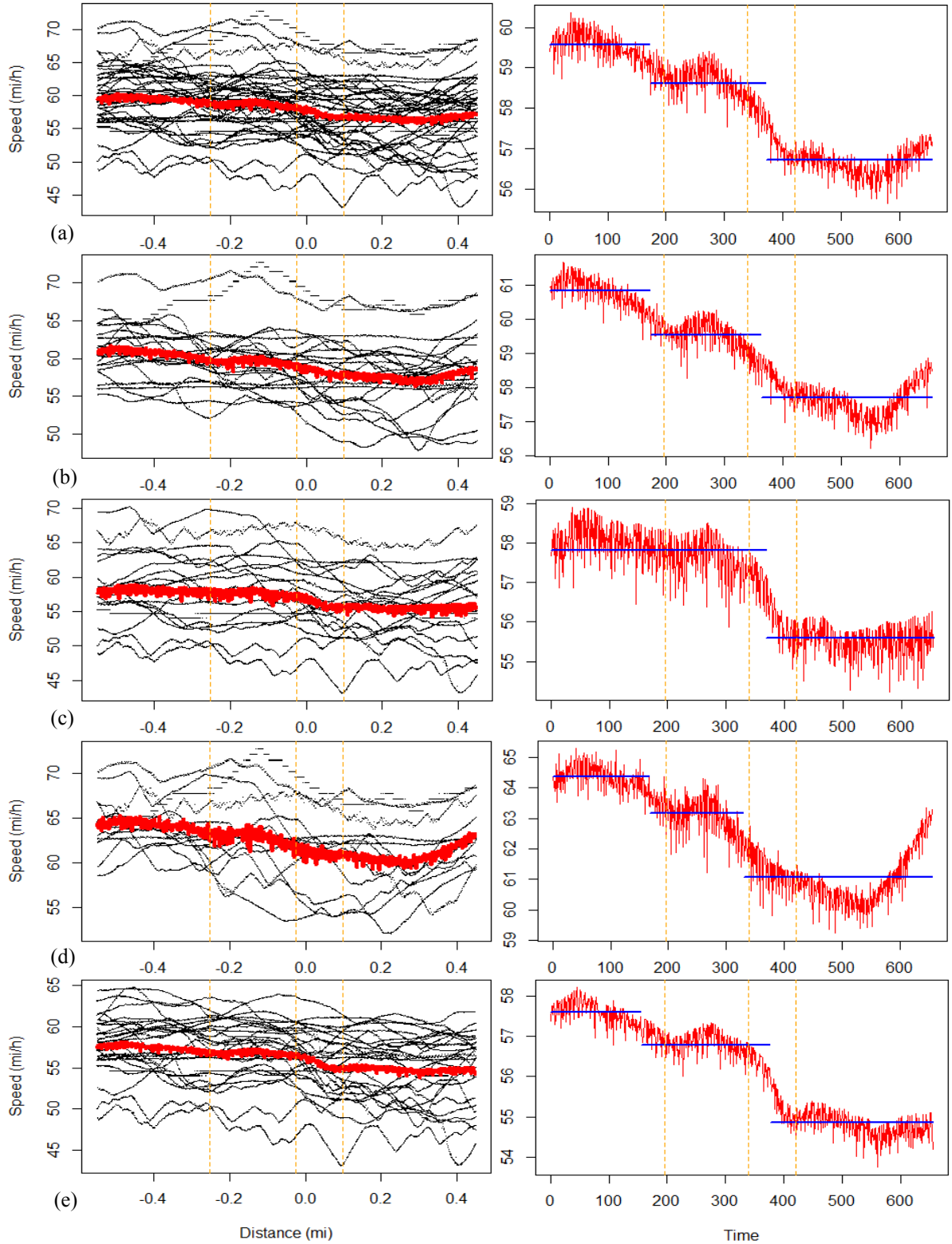

**Figure 3.19** Developing multiple changepoint models for work zone six  
 Left panel. Plot of mean speed of time series traces for overall traces (a), male drivers (b), female drivers (c), closed lane traces (d), and open lane traces (e). Right panel. Adjusted detected multiple changepoints for the corresponding categories to the left

The other changepoint occurred in reaction to the shoulder closure location and the work area.

### 3.5.6.1 Analysis Results Summary

The results of multiple changepoint detection models for all five groups in the work zone with left shoulder closure are summarized in Table 3.11. The average mean speed upstream of the first warning sign was from 5% to 17% higher than the roadway speed limit among all groups in this work zone. Outside lane drivers' speed was 64.4 mph compared to 57.6 mph for inside lane drivers. Male drivers mean speed was 60.8 mph compared to 57.8 mph for female drivers.

All groups had a slight reaction to the first work zone warning sign at about 1,500 feet upstream of the shoulder closure location. The female drivers had no reaction to this sign.

**Table 3.11 Summary of multiple changepoints detected in work zone 6**

Model Input Data Group	Multiple Changepoints PELT Model Results					
	Mean Speed (mph) Upstream	Change in Mean Speed (mph)	Mean Speed (mph) Reaction to first WZ warning sign	Change in Mean Speed (mph)	Mean Speed (mph) Reaction to Shoulder closure and work area	Overall Mean Speed Reduction (mph)
All (40 Traces)	59.6	-1.0	58.6	-1.9	56.7	-2.9
Male drivers (22 Traces)	60.8	-1.2	59.6	-1.9	57.7	-3.1
Female drivers (18 Traces)	57.8	0.0	57.8	-2.2	55.6	-2.2
Outside lane (13 Traces)	64.4	-1.2	63.2	-2.1	61.1	-3.3
Inside lane (27 Traces)	57.6	-0.8	56.8	-2.2	54.6	-3.0

The other major changepoint occurred at the start of the shoulder closure and the work area. The mean speed reduction was ranged between 1.9 to 2.2 mph.

The overall mean speed reduction was 2.9 mph for all drivers. The female drivers' mean speed was reduced to 55.6 mph after 2.2 mph reduction. After reacting to all provided safety measures, outside lane drivers' mean speed reduced to 61.1, which was 6.1 miles higher than the speed limit. The presence of the safety features helped to reduce the overall speed slightly, though it was not enough for the drivers who were driving in the outside lane.

### **3.5.7 Right Shoulder Closure**

The analysis in this section is on work zone seven with a right shoulder closure on a 4-lane divided highway. There were 41 speed time series traces for drivers traveled through this work zone. The roadway speed limit was 65 mph and there was no work zone speed limit. The distributions of speed traces are shown in Appendix 3. The speed profiles distribution reveals less variability within each trace and more variability between the traces. A series of safety features applied in this work zone included the first warning sign at about 2,700 feet, the second warning sign at about 1,000 feet upstream of the shoulder closure, and the shoulder closed sign.

The multiple changepoint models detected only one changepoint in reaction to the closed shoulder and the work area. The mean speed plots reveal drivers mainly started to react to the shoulder closure right at the second warning sign. The male drivers, on the other hand, started to react later at about 200 feet upstream of the shoulder closure point. The data in the inside lane show a similar pattern of that for male drivers as 18 out of 23 male traces occurred on the inside lane.

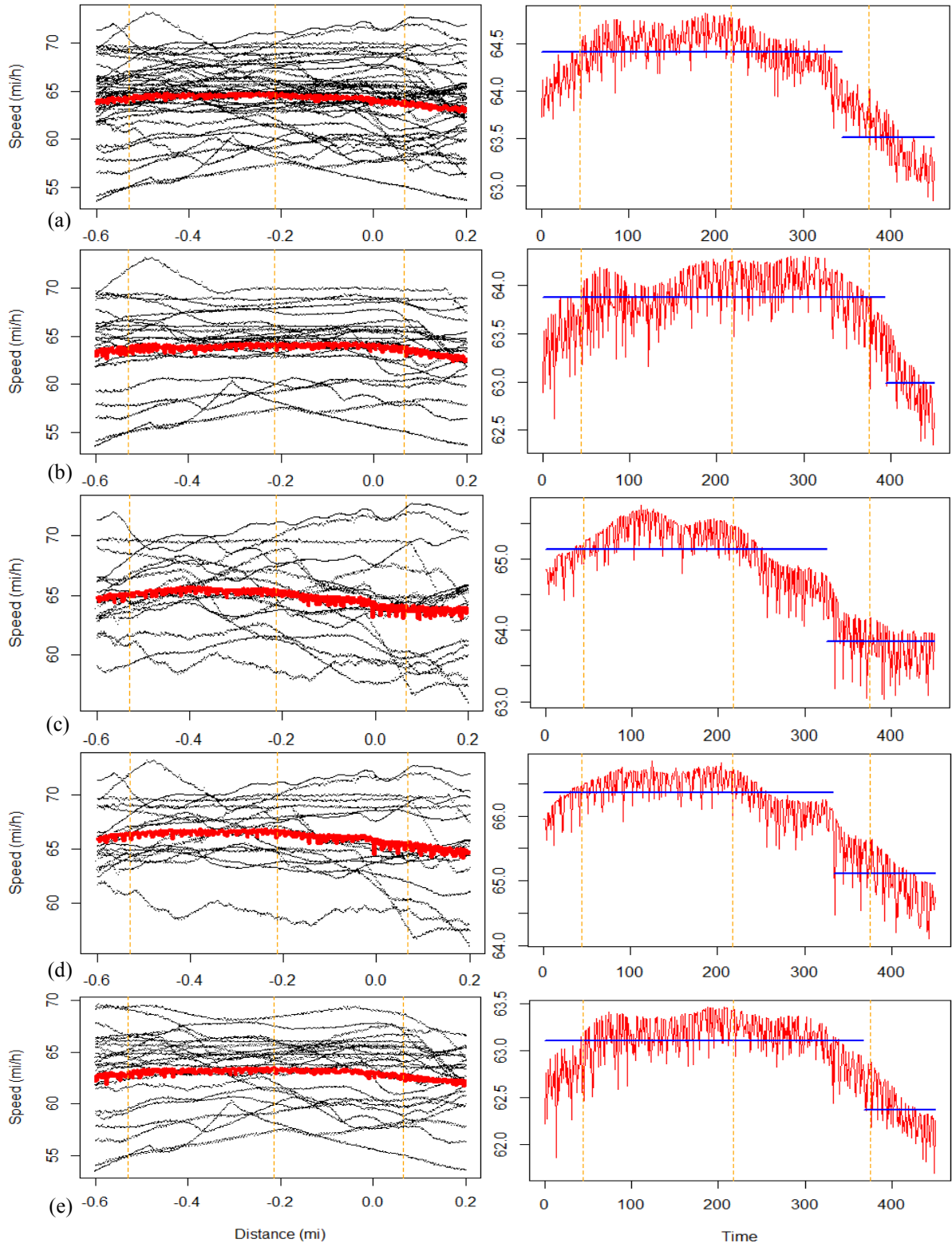

**Figure 3.20 Developing multiple changepoint models for work zone seven**  
 Left panel. Plot of mean speed of time series traces for overall traces (a), male drivers (b), female drivers (c), closed lane traces (d), and open lane traces (e). Right panel. Adjusted detected multiple changepoints for the corresponding categories to the left

### 3.5.7.1 Analysis Results Summary

The results of multiple changepoint detection models in work zone seven with right shoulder closure are summarized in Table 3.12. The average mean speed upstream of the first work zone warning sign all the way to the reaction point was around 65 mph for all groups which was same as speed limit. The male drivers mean speed was 63.9 mph compared to 65.1 mph for female drivers. Also, the outside lane drivers' mean speed was 66.4 mph and was 3.3 mph higher than that for inside lane drivers. Female drivers, who happened to drive mainly on the outside lane, had the highest reaction to the shoulder closure and the work area by reducing their speed by 1.3 mph. Male drivers reduced their overall speed by 0.9 mph from 63.9 to 63 mph.

**Table 3.12 Summary of multiple changepoints detected in work zone 7**

Model Input Data Group	Multiple Changepoints PELT Model Results			
	Mean Speed (mph) Upstream	Change in Mean Speed (mph)	Mean Speed (mph) Reaction to closed Shoulder and work area	Overall Mean Speed Reduction (mph)
All (41 Traces)	64.4	-0.9	63.5	-0.9
Male drivers (23 Traces)	63.9	-0.9	63.0	-0.9
Female drivers (18 Traces)	65.1	-1.3	63.8	-1.3
Outside lane (17 Traces)	66.4	-1.3	65.1	-1.3
Inside lane (24 Traces)	63.1	-0.7	62.4	-0.7

### 3.5.8 Both Shoulders Closure

The analysis in this section is on work zone eight with both shoulders closed on a 4-lane divided highway. There were 49 speed time series profiles of drivers traveled through this work zone. The roadway speed limit was 65 mph and there was no work zone speed limit. The distributions of speed traces are shown in Appendix 3. The speed variation is about 20 mph among all speed time series. The majority of speeds vary between 50 and 65 mph. A series of safety measures applied in this work zone included the first work zone warning sign at about 2,100 feet, the second work zone warning sign at about 1,700 feet, and the third work zone warning sign at about 650 feet upstream of shoulders closure.

There were 4 changepoints detected in the model for all five groups. There was no data available upstream of the first warning sign. The average mean speed at the first warning sign, located at about 2,100 feet upstream of the shoulder closure, ranged between 59.4 and 62.5 mph. The plots show the mean speed for all drivers increased until 1,350 feet upstream of the shoulder closure and remained steady until about 250 feet away from the closure point, where they started to react to the shoulder closure.

#### 3.5.8.1 Analysis Results Summary

The results of multiple changepoint detection models for all 5 groups in the work zone with both shoulders closed are summarized in Table 3.13. The first changepoint was an increase of about 1 mph between the first shoulder work warning sign and the second and third warning signs. The next changepoint was in reaction to the shoulder closure and the first bridge work area. The mean speed reduction was 1.5 mph for all. The speed reduction was 1.7 mph for outside lane drivers as the highest decrease and 1.4 mph for male drivers as the lowest decrease.

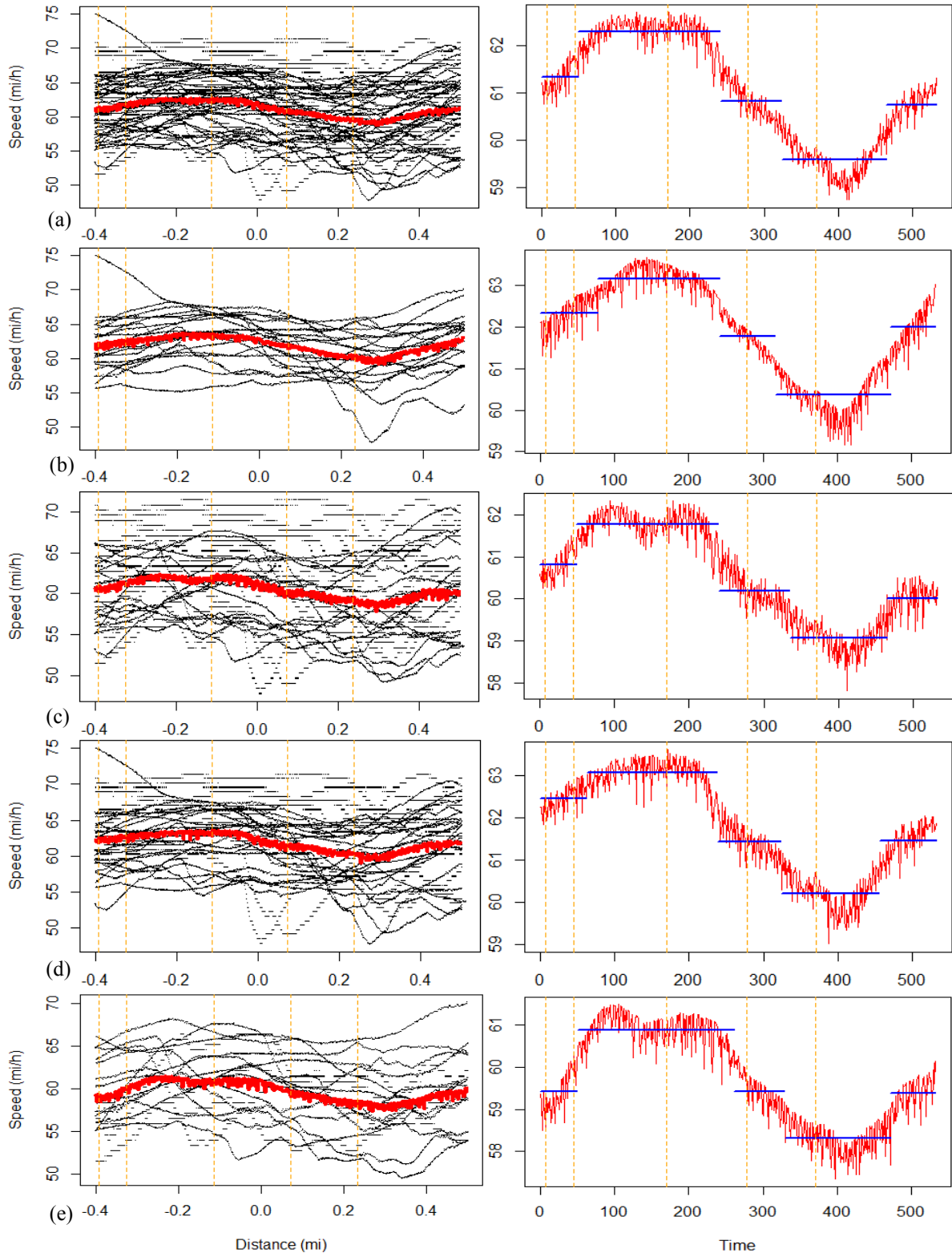

**Figure 3.21 Developing multiple changepoint models for work zone eight**

Left panel. Plot of mean speed of time series traces for overall (a), male drivers (b), female drivers (c), closed lane traces (d), and open lane (e). Right panel. Adjusted detected multiple changepoints for the corresponding categories to the left

The next identified changepoint occurred at the second bridge work area on both sides of the roadway. There was an average speed reduction of 1.2 mph for all drivers. This was slightly higher for male drivers with 1.4 mph. The highest overall speed reduction was 2.3 mph for outside lane drivers which reduced their speed from 62.5 to 60.2 mph. The lowest overall speed reduction was for inside lane drivers at 1.1 mph by changing their speed from 59.4 to 58.3 mph. Male drivers' speed reduced from 62.3 to 60.4 mph and female drivers' speed reduced to 59 mph from 60.8 mph. The last changepoint was an increase of speed by 1.1 mph for overall group when drivers reaching toward the end of construction zone.

**Table 3.13 Summary of multiple changepoints detected in work zone 8**

Model Input Data Group	Multiple Changepoints PELT Model Results							
	Mean Speed (mph) 1st warning sign	Change in Mean Speed (mph)	Mean Speed (mph) Reaction to 2nd & 3rd WZ warning sign	Change in Mean Speed (mph)	Mean Speed (mph) Reaction to 1st bridge work area	Change in Mean Speed (mph)	Mean Speed (mph) Reaction to 2nd bridge work area	Overall Mean Speed Reduction (mph)
All (49 Traces)	61.3	1.0	62.3	-1.5	60.8	-1.2	59.6	-1.7
Male drivers (19 Traces)	62.3	0.9	63.2	-1.4	61.8	-1.4	60.4	-1.9
Female drivers (30 Traces)	60.8	1.0	61.8	-1.6	60.2	-1.2	59.0	-1.8
Outside lane (32 Traces)	62.5	0.6	63.1	-1.7	61.4	-1.2	60.2	-2.3
Inside lane (17 Traces)	59.4	1.5	60.9	-1.5	59.4	-1.1	58.3	-1.1



### 3.5.9 Lane Shift

Work zone nine demonstrates a lane shift on 4-lane divided rural highway. There were 39 speed time series traces in this work zone. The speed distributions of time series profiles are shown in Appendix 3. The speed distributions show almost all drivers driving at a speed higher than the speed limit of 55 mph throughout the work zone's designated boundaries. The only exception is female drivers who drive at a range of 50-54 mph. There was no speed reduction required for this work zone. A series of safety measures applied in this work zone included the first work zone warning sign, the highway guide sign, barrels tapering the shoulder, and lane shift with shoulders closed sign.

There were 4 changepoints detected by PELT models for overall, male, and inside lane drivers, but only 3 changepoints detected for female and outside lane drivers. The plots show almost all drivers started to react to the first work zone warning sign by reducing their speed by about 1 mph. The only exception was open lane drivers who maintained their upstream speed and had no reaction to the first sign. All five groups increased their speed by as much as 5 mph after the first warning sign until they reached about 700 feet upstream of the highway guide sign, when they started to reduce their speed until 500 feet after the guide sign. There was a period of low speed increases before they started to react to the presence of barrels on left shoulder at about 1,000 feet upstream of the lane shift zone. The increased speed was for all groups except the inside lane drivers, who continuously decreased their speed to the lane shift location.

Lastly, drivers of all groups reduced their speeds quickly in reaction to the lane shift with both shoulder closed sign. At the point where the lane shift started, outside lane drivers reduced their speed about 4.4 mph, which is still about 8% above the speed limit

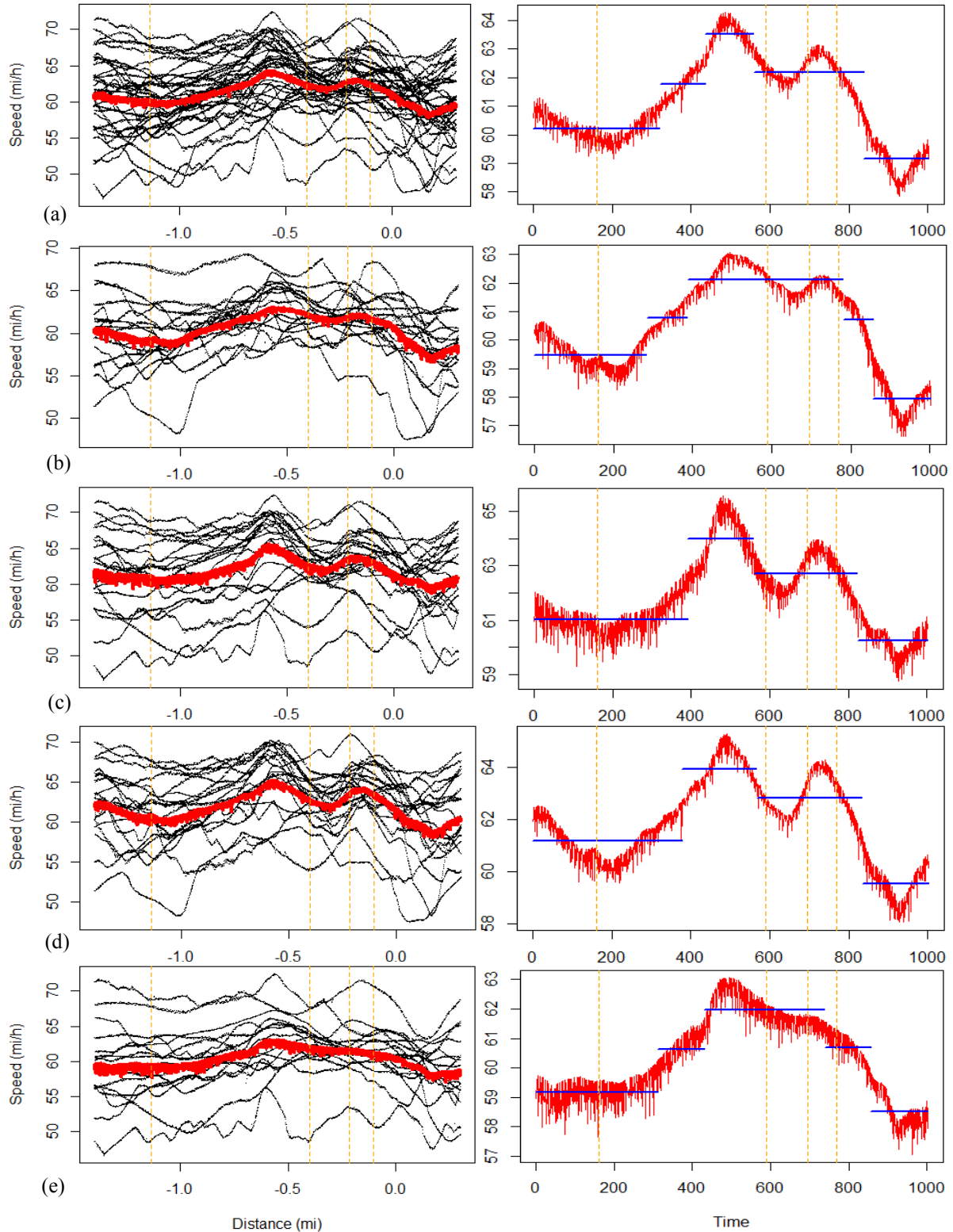

**Figure 3.22 Developing multiple changepoint models for work zone seven**

Left panel. Plot of mean speed of time series traces in work zone 9 for overall (a), male drivers (b), female drivers (c), closed lane traces (d), and open lane (e). Right panel. Adjusted detected multiple changepoints for the corresponding categories to the left

### 3.5.9.1 Analysis Results Summary

The results of multiple changepoint detection models for all five groups in the work zone with lane shift situation are summarized in Table 3.14. The average mean speed at the upstream of the first warning sign for all groups ranged from 59.2 mph for inside lane to 61.2 mph for outside lane drivers. It should be noted that 12 out of 21 traces in the outside lane and 7 out of 16 traces in the inside lane were female drivers. Male drivers' upstream speed was 59.5 mph compared to 61 mph for female drivers.

The first changepoint in the model was an increase of between 2.6 and 3.3 mph for all five groups. The increased speed occurred between the first work zone warning sign at about 1.1 mile upstream of the lane shift location and close to the second warning sign at about 0.5 mile upstream of the work area.

**Table 3.14 Summary of multiple changepoints detected in work zone 9**

Model Input Data Group	Multiple Changepoints PELT Model Results							
	Mean Speed (mph) Upstream	Change in Mean Speed (mph)	Mean Speed (mph) between 1st & 2nd WZ warning sign	Change in Mean Speed (mph)	Mean Speed (mph) 2nd WZ warning sign	Change in Mean Speed (mph)	Mean Speed (mph) Reaction to lane shift	Overall Mean Speed Reduction (mph)
All (39 Traces)	60.2	3.3	63.5	-1.3	62.2	-3.1	59.1	-1.1
Male drivers (18 Traces)	59.5	2.6	62.1	-1.4	60.7	-2.8	57.9	-1.6
Female drivers (19 Traces)	61.0	3.0	64.0	-1.3	62.7	-2.5	60.2	-0.8
Outside lane (21 Traces)	61.2	2.7	63.9	-1.1	62.8	-3.3	59.5	-1.7
Inside lane (16 Traces)	59.2	2.8	62.0	-1.3	60.7	-2.2	58.5	-0.7

The next changepoint was in reaction to the highway guide sign, which resulted in a mean speed reduction of up to 1.4 mph for male drivers and 1.1 mph for outside lane drivers.

The last changepoint was detected as drivers approached the lane shift location and the work area, with the highest decrease for outside lane drivers at 3.3 mph, and a decrease of only 2.2 mph for inside lane drivers. Male drivers had slightly higher speed reductions at the lane shift area with 2.8 mph compared to 2.5 mph for female drivers.

The overall mean speed reduction in reaction to a series of safety measures in this work zone was about 1.8% for overall drivers. The range of mean speed reductions was between 1.3% and 2.8% for female and outside lane drivers, respectively. The main reaction started closer to the lane shift area and before the highway guide sign. When mean speed reductions were measured from the upstream of the guide sign to the lane shift area, a range of 1.8% to 7.2% speed reductions were observed among all groups. The large distance between the first and second work zone warning sign caused an increase of speed due to no work zone activity in this area.

### **3.6 Summary and Discussion**

The objective of this research was to understand how drivers interact with various work zone characteristics and how a series of safety measures applied in work zones attracts drivers' attention to comply with work zone requirements. This was done by developing multiple changepoint models to effectively and efficiently find the location of changepoint in mean speed in reaction to various safety features in the work zone. A total of 9 work zones which had 471 time series speed profiles and involved 230 unique drivers, were evaluated. The findings of this study could be used to better understand drivers, behavior in work zones and provide recommendations to transportation agencies about their traffic control plans,

safety measures layout, and the use of a specific safety feature in work zones. This study analyzed work zones on different roadway types, with various work zone configurations, and diverse safety measures layout.

### 3.6.1 Speed Profile Dispersion

The study examined the safety measures on four different work zones with left lane closed situation, one work zone with right lane closure, three work zones each with left, right, or both shoulder closures, and one work zone with lane shift condition. The objective for selection of these work zones was to examine all possible safety feature types, in different layouts, and on diverse roadway types based on availability of an acceptable number of speed time series traces. The speed profiles distributions for all nine work zones are provided as boxplots in Figure 3.23.

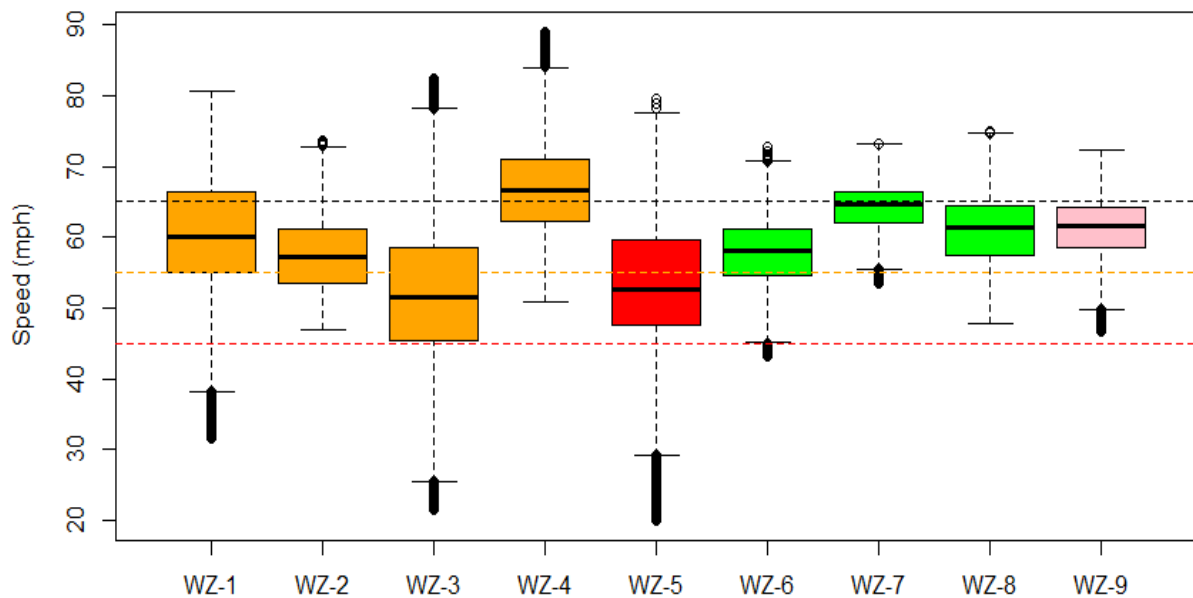

**Figure 3.23 Speed profile distributions for all 9 work zones in the study**

Work zones 1 through 4 (WZ-1 – WZ-4) have left lane closed configurations and are demonstrated with orange boxes. Work zone 5 is right lane closed in a red box, work zone 6

to 8 with green boxes are shoulder closure situations, and a lane shift represented by work zone 9 with a pink box. The red dashed line represents a work zone speed limit of 45 mph for work zones 3 and 5. The work zone speed limit of 55 mph for work zones 1, 2, 6, and 9 is demonstrated by an orange dashed line. The black dashed line shows the work zone speed limit of 65 mph for work zones 7 and 8 which is the same as the roadway speed limit.

There is a vast speed dispersion for work zones with lane closures and, more specifically, for those which had low speed limits of 45 mph. The exceptions are work zone 2, and 4 which show lower speed variations compared to other lane closure scenarios. The safety measures layout in work zone 2 was different as it started with a lane merge sign and was followed by a DMS which was about 1,400 feet upstream of the transition area. There is a possibility that other safety measures exist prior to the lane merge sign, which might be the reason for the lower speed variations. The low speed variation of work zone 4 might be due to a no speed limit reduction requirement.

The speed variations for shoulder closures and lane shift are much lower compared to lane closure conditions. This may be due to the fact that no speed reductions were required for these situations. The colored boxes represent the middle 50% spread of speed data with 25 percentile as lower spread and 75 percentile as higher spread. The speed data also shows a higher spread for lane closed work zones. The spread for the middle 50% of data ranged from 7 to about 13 mph for lane closures, about 3 to 7 mph for shoulder closures, and about 5 mph for lane shift conditions. Some of the speed variations can be explained by speed limit reductions required in some work zones with lane closures. There are some speed variations which cannot be explained by speed limit reduction, types and locations of the safety measures might be the source of those variation.

### 3.6.1.1 Speed Profile Dispersion by Gender

Speed time series profiles in each work zone were studied for all and various comparable groups of traces in that work zone. The study analyzed the speed profiles for male, female, open lane, and closed lane drivers. The speed profile distributions for male and female drivers involved in all 9 work zones are shown in Figure 3.24. Work zones configurations studied are divided into 4 categories, including left lane closed (WZ-1 to WZ-4) represented by a light-yellow shade, right lane closed (WZ-5) denoted by a light-red shade, shoulder closed (WZ-6 to WZ-8) demonstrated by a light-green shade, and lane shift (WZ-9) represented by a light-pink shade.

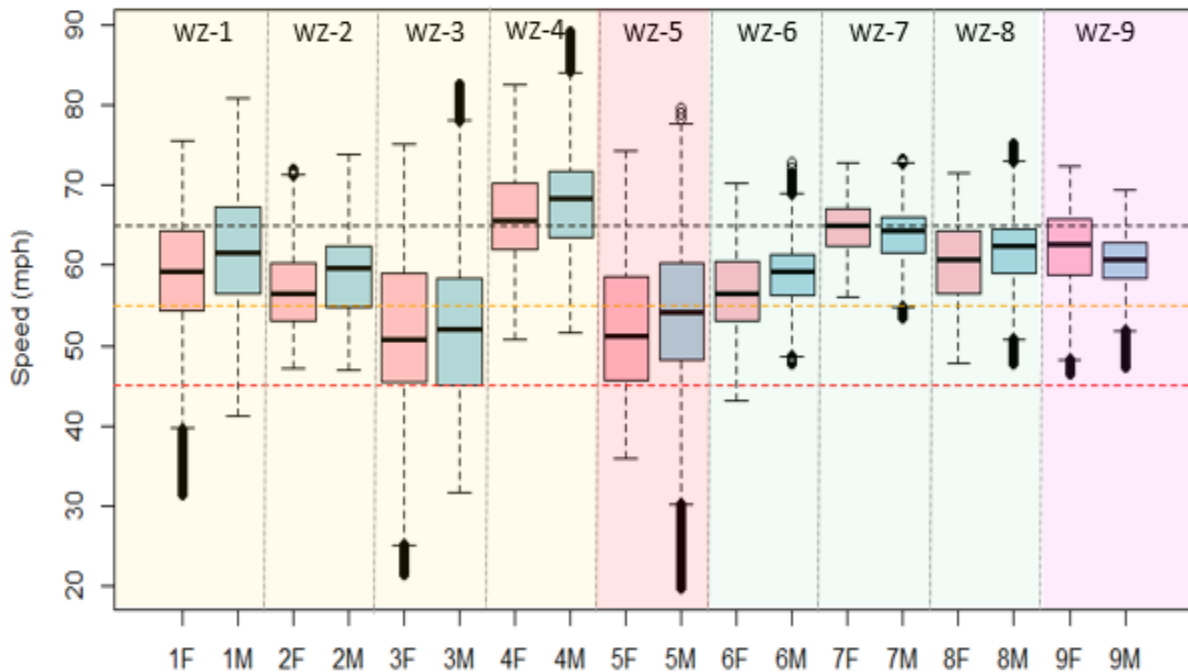

**Figure 3.24 Speed profile distributions by gender for all 9 work zones in the study**

The y-axis represents the vehicle speed in mph and the x-axis shows 9 pairs of boxplots, two for each work zone. The 1F represents female drivers' speed profile distribution in pink and 1M denotes male drivers' speed traces distribution with a blue color

for the first pair of boxplots in work zone 1. Similarly, each pair of boxplots from 2F and 2M to 9F and 9M shows the female and male drivers' speed profile distributions for the corresponding work zones.

There is a high speed dispersion in work zones 1, 3, and 5 which involved lane closure conditions. The range and 50% middle spread is pretty similar for both genders; however, the median speeds of male drivers are slightly higher compared to female drivers in all lane closure scenarios. More than 75% of the speeds are higher than work zone speed limits in work zones with lane closures and work zone speed limits are 10 mph lower than the actual roadway speed limits. The speed variation is relatively low for work zone 2 which has a similar 10 mph speed reduction but different safety measures' layout. The middle 50% spread is about 8 mph for both genders compared to 11 mph for work zone 1. Female drivers' speed in work zone 2 is slightly right-skewed; more speed traces tend toward the lower spread while male drivers' speeds tend more toward the higher spread. Work zone 4 involves left lane closure with no speed limit reduction on a multi-lane divided highway with a 70 mph roadway speed limit. The middle 50% spread varies about 8 mph for both genders. The median is 66 and 69 mph for female and male drivers, respectively. The medians here are lower than the posted speed limit of 70 mph. It shows reducing the speed limit does not necessarily cause drivers to slow down. It is the safety measures and their layouts which have a greater effect in getting drivers' attention to slow down.

The lowest variations are when road work involves no lane closures as is the case for work zones 6 through 9. The speed middle 50% spread variation is about 4-5 mph for male drivers and 5-7 mph for female drivers when no speed reduction is required. The median speed is about 2 mph higher for male drivers in left shoulder closure and both shoulder



closures, similar in right shoulder closure, and about 1.5 mph higher for female drivers in lane shift scenarios.

The highest speed variations for both genders belong to work zones 3 and 5 with left lane and right lane closures, respectively. The work zone speed limit for both work zones is 45mph. The range of speed traces is between 25 and 65 mph for female drivers and between 30 and 78 mph for male drivers. The median speed for both genders is around 52 mph in work zone 3 with the spread of middle 50% data from 45 to 59 mph. The female speeds are slightly right skewed which means more speed traces tend toward the lower range of spread with higher concentrations toward the higher range of spread for male drivers. For work zone 5, the median speed for male drivers is 55 mph compared to 52 mph for female drivers. The speed dispersion is higher for male drivers, ranged from 30 to 78 mph with some outliers outside both low and high ranges. The speed for female drivers scattered between 35 and 74 mph with no outliers outside the ranges. The 50% middle spread is quite identical for both groups.

### ***3.6.1.2 Speed Profile Dispersion by Driving Lane***

The speed profile distributions for closed and open lane traces for all 9 work zones are shown in Figure 3.25. The x-axis shows two boxplots for each work zone. The 1CL represents closed lane speed traces in red and 1OP shows open lane speed profiles with a green color in work zone 1. Similarly, each pair of boxplots from 2CL and 2OP to 5CL and 5OP represent closed lane and open lane and from 6IN and 6OUT to 9IN and 9OUT show inside and outside lane speed profiles for the corresponding work zones.

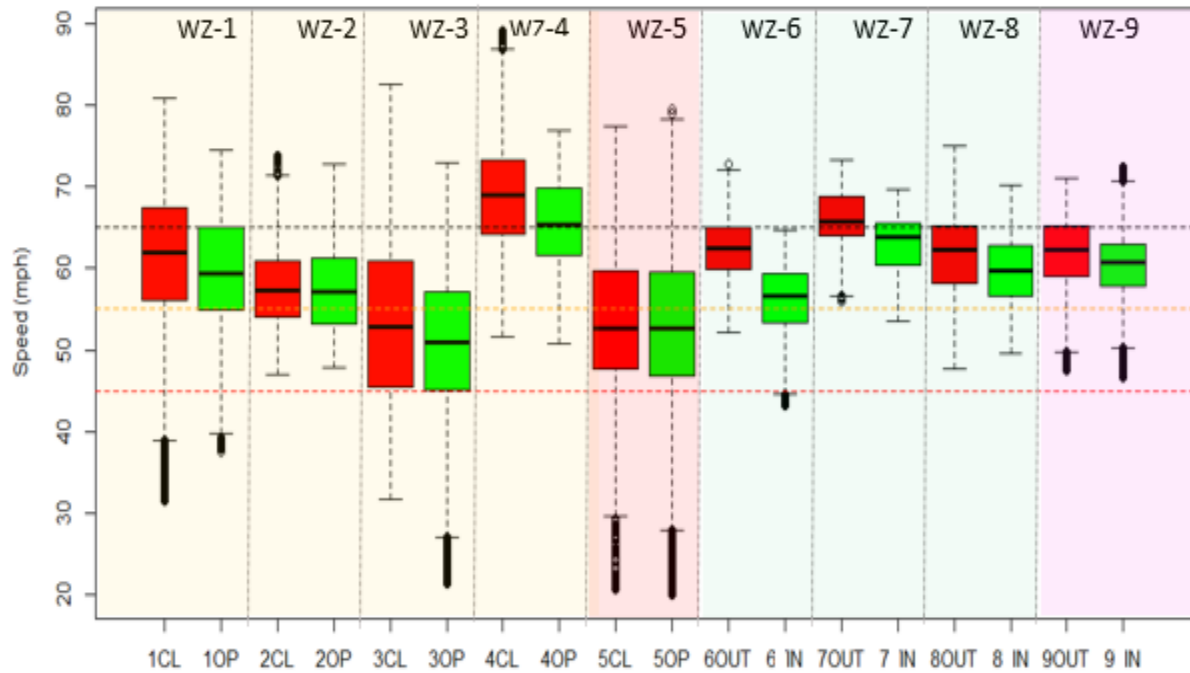

**Figure 3.25 Speed profile distributions by driving lane for all 9 work zones in the study**

The speed time series distributions in closed and open lane are compared. The closed lanes are outside lane for all work zones but 5, which has a right lane closure (inside lane closed). The median speed is higher in closed lane or outside lane across all work zones except 2 and 5, which have similar median speed in both closed and open lanes. The median speed for work zones with no lane closure is about 2 to 6 mph higher in outside lane with lane shift in lower and left shoulder closure in the higher end of the range. In work zones with lane closure conditions, the range of median speed in closed lane is between zero and 3 mph higher compared to open lane. The speed profiles 50% middle spread is slightly higher for the closed lane speed traces across the majority of the work zone with lane closures and lane shift. The exceptions are work zone 2 and 5, which have a higher spread for open lane. The spread in work zones with shoulder closures is slightly higher for open lane compared to closed lane.

Overall, there was a substantial speed variations for lane closures and speed reduction scenarios. However, the magnitude of dispersion depends on the safety measures' layout. It also shows less variation for the case of lane closures with no speed reductions and even lower variations for the shoulder closures and lane shift scenarios with no speed reductions. Male drivers' median speed was higher than that for female drivers. The median speed was also higher in closed lane when compared to open lane traces, particularly when there was no lane closures in work zones. Some of the speed dispersion could be explained by lane closures and speed reductions but still all possible sources and main locations of variations needed to be investigated.

### **3.6.2 Countermeasures Effectiveness**

To examine the effects of safety measures' layout in changing driver behavior, the potential changepoints in the mean speed over various work zones with different characteristics were studied. A multiple changepoint analysis model was used to create a model which predicted driver reaction to various work zone safety measures. Speed time series data were used to develop changepoint models by utilizing PELT algorithm to accurately and efficiently estimate the locations of multiple changepoints for the mean of time series traces over 9 work zones with different characteristics. The results of changepoint models revealed how different countermeasure or series of countermeasures affected drivers to react and to reduce their speeds and are shown in Table 3.15. The changepoint models for various groups within the work zone identified if their reactions to a similar safety measure were different. In some locations, the effect of an individual safety measure was not detected due to the close proximity of the safety measures and the simultaneous effect on drivers.

Table 3.15 Multiple changepoint results for all work zones

Work Zone	Work Zone Characteristics	Change in Mean Speed from the Upstream detected at Safety Measures' Location										
		Speed Time Series Group	Road way Speed Limit (mph)	WZ Speed Limit (mph)	Mean speed Upstream (mph)	Change in Mean Speed due to 1st Warning Sign /DMS / DSFS (mph)		Change in Mean Speed at Taper Area (mph)		Mean Speed Work Area (mph)	Change in Mean Speed at Work Area (mph)	
1	Left lane closed 4-lane divided DMS after 1st WZ warning sign	Overall	65	↓ 55	66.8	-1.5	-2.1%	-5	-7.6%	52.2	-14.5	-24.4%
		Male			68.5	-1.6	-2.4%	-5.3	-8.0%	53.5	-15	-24.6%
		Female			65.6	-1.7	-2.6%	-5.1	-8.1%	51.1	-14.5	-24.9%
		Closed lane			68.1	0	0.0%	-5.5	-8.4%	51.4	-16.7	-27.9%
		Open lane			65.2	-1.5	-2.3%	-4	-6.3%	53.4	-11.8	-19.9%
2	Left lane closed 4-lane divided DMS after lane closed sign	Overall	65	↓ 55	61.9	-2.1	-3.5%	-4.6	-7.7%	55.4	-6.5	-11.1%
		Male			63.5	-2.3	-3.7%	-3.9	-6.3%	57	-6.5	-10.8%
		Female			61.1	-2.6	-4.3%	-5	-8.5%	54.7	-6.4	-11.1%
		Closed lane			63.8	-2.6	-4.2%	-6.4	-10.6%	55.1	-8.7	-14.6%
		Open lane			59.2	2.8	4.6%	1.5	2.5%	58.5	-0.7	-1.2%
3	Left lane closed 4-lane divided DSFS after 1st WZ warning sign	Overall	55	↓ 45	63	-4.7	-7.7%	-14.8	-26.6%	43.2	-19.8	-37.3%
		Male			63.1	-4.6	-7.6%	-14.6	-26.2%	43.5	-19.6	-36.8%
		Female			62.8	-4.9	-8.1%	-15	-27.1%	42.4	-20.4	-38.8%
		Closed lane			65.6	-4.9	-7.8%	-16.9	-29.6%	43.6	-22	-40.3%
		Open lane			60.7	-4.4	-7.5%	-12.9	-23.8%	42.8	-17.9	-34.6%
4	Left lane closed multi-lane divided	Overall	70	70	70.3			-3.6	-5.3%	62.7	-7.6	-11.4%
		Male			71.3			-4.2	-6.1%	62.7	-8.6	-12.8%
		Female			70.3			-4.3	-6.3%	62.5	-7.8	-11.7%
		Closed lane			73			-5.1	-7.2%	63.5	-9.5	-13.9%
		Open lane			69.2			-3.7	-5.5%	62.2	-7	-10.7%
5	Right lane closed 4-lane divided DSFS	Overall	55	↓ 45	62	-3.5	-5.8%	-11.8	-21.0%	46.1	-15.9	-29.4%
		Male			62.4	-3.1	-5.1%	-10.8	-18.9%	46.7	-15.7	-28.8%
		Female			61.7	-4.3	-7.2%	-13.9	-25.4%	44	-17.7	-33.5%
		Closed lane			61.6	-3.3	-5.5%	-11.2	-20.0%	46.4	-15.2	-28.1%
		Open lane			63.4	-4.6	-7.5%	-13.7	-24.2%	44.7	-18.7	-34.6%
6	Left shoulder closed 4-lane divided	Overall	55	55	59.6	-1	-1.7%	-2.9	-5.0%	56.7	-2.9	-5.0%
		Male			60.8	-1.2	-2.0%	-3.1	-5.2%	57.7	-3.1	-5.2%
		Female			57.8	0	0.0%	-2.2	-3.9%	55.6	-2.2	-3.9%
		Outside lane			64.4	-1.2	-1.9%	-3.3	-5.3%	61.1	-3.3	-5.3%
		Inside lane			57.6	-0.8	-1.4%	-3	-5.3%	54.6	-3	-5.3%
7	Right shoulder closed 4-lane divided	Overall	65	65	64.4			-0.9	-1.4%	63.5	-0.9	-1.4%
		Male			63.9			-0.9	-1.4%	63	-0.9	-1.4%
		Female			65.1			-1.3	-2.0%	63.8	-1.3	-2.0%
		Outside lane			66.4			-1.3	-2.0%	65.1	-1.3	-2.0%
		Inside lane			63.1			-0.7	-1.1%	62.4	-0.7	-1.1%
8	Both shoulder closed 4-lane divided	Overall	65	65	61.3	1	1.6%	-0.5	-0.8%	60.8	-0.5	-0.8%
		Male			62.3	0.9	1.4%	-0.5	-0.8%	61.8	-0.5	-0.8%
		Female			60.8	1	1.6%	-0.6	-1.0%	60.2	-0.6	-1.0%
		Outside lane			62.5	0.6	1.0%	-1.1	-1.8%	61.4	-1.1	-1.8%
		Inside lane			59.4	1.5	2.5%	0	0.0%	59.4	0	0.0%
9	Lane shift 4-lane divided	Overall	55	55	60.2	3.3	5.3%	-1.1	-1.8%	59.1	-1.1	-1.8%
		Male			59.5	2.6	4.3%	-1.6	-2.7%	57.9	-1.6	-2.7%
		Female			61	3	4.8%	-0.8	-1.3%	60.2	-0.8	-1.3%
		Outside lane			61.2	2.7	4.3%	-1.7	-2.8%	59.5	-1.7	-2.8%
		Inside lane			59.2	2.8	4.6%	-0.7	-1.2%	58.5	-0.7	-1.2%

### **3.6.2.1 Static Signs**

The models' results revealed a minimal or no reactions to the first and second warning signs when they were applied as standalone signs like work zones 6-8 with shoulder closures, 9 with lane shift, and 4 with closed lane characteristics. The effect of the static warning signs were detected when they were combined with other signs such as the DMS in work zone 1 and the DSFS in work zones 3 and 5. The other static signs in all work zones included lane closed signs and speed limit signs were combined with other safety measures such as tapering, channelization, and flashing arrows. The effect of these signs was not individually detected in the developed multiple changepoint models in various work zones.

### **3.6.2.2 Dynamic Message Sign (DMS)**

There were reactions to the first work zone warning sign when it was combined with a DMS, as is the case in work zone 1. The reaction varied among the involved categories. The closed lane drivers had no reaction to the combination of these two safety measures, while female and male drivers reduced their speed by 2.6 and 2.4%, respectively. The overall reaction was about 2.1% in speed reduction to the combination of these two safety features.

When a DMS was applied after the lane closed sign at about 1,400 feet upstream of the taper area, drivers had higher speed reductions as a result. The female drivers reduced their speed by as much as 4.3%, male drivers 3.7%, closed lane drivers 4.2%, and 3.5% for overall traces. This was about an average of 50% higher speed reduction compared to the case when the DMS was applied at about 4,300 feet upstream of taper area. The open lane drivers showed no reaction to the DMS and their speed was actually increased by 4.6%. This may be due to their lower speed before approaching the DMS compared to other categories.

The effect of the DMS individually could not be identified as a change point detected over combinations of safety measures.

### ***3.6.2.3 Dynamic Speed Feedback Sign (DSFS)***

The combinations of the first work zone warning sign and the DSFS were more successful in getting drivers' attention to reduce their speed. The effect was higher when they were applied in work zone 3 with a left lane closed configuration. The average speed reduction was 7.7% compared to 6.2% for a right lane closure in work zone 5. Female drivers had the highest reaction with an 8.1% speed reduction and open lane drivers had a 7.5% speed reduction as the lowest reaction in work zone 3. The case was different for open lane drivers in work zone 5 as the open lane (outside lane) drivers had the highest reaction of 7.5%, with the lowest reaction for the male drivers by a 5.1% speed reduction. The female drivers' reaction to the combined effects of the first warning sign and the DSFS was 7% and 35% higher than male drivers in work zones 3 and 5, respectively. The highest reaction was for open lane (outside lane) drivers in work zone 5 at 31% over closed lane drivers.

### ***3.6.2.4 Tapering, Channelization, and Flashing Arrow***

The combinations of tapering, channelization, and flashing arrow were very effective in getting drivers' attention to slow down in work zones with lane closure configurations. The greatest reduction in speed was observed at work zones 3 and 5 with a 45 mph work zone speed limit. The highest speed reduction was for closed lane drivers by 22% for work zone 3 with a left lane closure, while it was a 15% reduction for the same lane in right lane closure scenario at work zone 5. The speed reduction of about 19% was observed for female drivers in work zone 3 and 5. The speed reduction for male drivers was 14% in work zone 5.

compared to 18.7% in work zone 3. It appears the application of these safety measures were more effective in left lane closure compared to the right lane closure scenario by about 22%.

The combined effect of these safety measures was ranged between 2% to 8.5% for all other left lane closures scenarios and participating drivers' groups. The highest reduction was for closed lane drivers in work zone 1 and the lowest was about 2% for open lane drivers in work zone 2. The reactions ranged from 4% to 8.4% among all groups and were virtually similar for work zone 1 with 10 mph speed reduction and work zone 4 with no speed reduction. The lowest overall reaction was for work zone 2 by a 4.3% reduction in mean speed.

There was no flashing arrow in work zones with shoulder closures and lane shift scenarios. The reactions to shoulder closures and lane shift were observed to be lower than for lane closure scenarios, ranged from 0.8% for male drivers in both shoulder closures in work zone 8 to a 4% for inside lane drivers in work zone 6 with left shoulder closure. Interestingly, outside lane drivers had lower reaction to the left shoulder closure with 3.3% speed reduction.

### ***3.6.2.5 Combined Effect of All Safety Features at the Work Area***

The combined effects of different safety measures layout will be beneficial in finding the most effective safety measures layout and recommendations for effective work zone safety plans. The combinations of the DSFS the flashing arrow, tapering and channelization had the highest combined effect in work zone 3 and 5 with an overall speed reduction of 37.3% and 29.4%, respectively. The highest reaction among all work zones with lane closure scenarios attributed to closed lane drivers, ranging from 14.6% to 40.3% speed reduction in work zone 2 and 3, respectively. The only exception was the right lane closed scenario of

work zone 5 in which open (outside) lane drivers had the highest reaction, reducing their speed by 34.6%.

There was a negligible effect of safety features layout in work zones with lane shift and shoulder closures as there were no speed reduction requirements. However, in the case of work zone 4 with lane closure and no speed reduction, the overall speed was reduced by as much as 14% for closed lane drivers in reaction to safety measures layout. Explanations for the speed reduction may include the roadway speed limit of 70 mph, drivers' perception of risk, one out of three lanes closed, and the presence of equipment and workers. These findings suggest that careful safety planning with a combination of effective safety features could get drivers' attention to slow down approaching a work area.

### **3.6.3 Reaction by Gender**

The results of multiple changepoint analysis using the PELT algorithm revealed female drivers' reaction to the first warning sign and the DSFS was about 35% higher in right lane closure and about 7% higher speed reduction in left lane closure scenarios compared to male drivers. In the case of DMS applications in work zone 1 and 2, female drivers reacted by 10.8% when a DMS was after work zone 1<sup>st</sup> warning sign and 16.4% higher when a DMS was closer to taper area at about 1,400 feet.

Female drivers also showed higher reactions to the presence of tapering, flashing arrow, and channelization. The speed reduction for female drivers was about 45% higher when a DMS was closer to a taper area and 27% higher at right lane closure scenarios.

There is a negligible difference between the two genders when reacting to the combined effects of tapering, channelization, and flashing arrow in left lane closure cases.



### 3.6.4 Reaction by Lane

Drivers in closed lane were driving at an average of 6% higher speed than open lane drivers. The reaction to the work zone first warning sign was much lower for closed lane drivers in the majority of closure cases. The speed reduction ranged between 10% and more than 200% lower compared to open lane drivers in the same scenarios. The only exception was in work zone 3 during which closed lane drivers had about 3% higher speed reduction than open lane drivers.

The highest reaction difference for closed and open lane drivers was observed at taper, flashing arrow, and channelization where speed reductions for closed lane drivers was 3 times as much as that for open lane drivers in lane closure scenarios. The only exception was when open lane drivers had a 20% higher reaction to these safety measures compared to closed lane drivers.

The reaction at the work area was also higher for closed lane drivers by as much as 36% higher speed reduction when compared to open lane drivers.

The overall effect of all safety measures combined at the work area also showed a higher speed reduction for closed lane drivers in work zones with lane closure conditions by as much as 170% for the work zone 2 when compared to open lane drivers. The only exception again was right lane closed case when open lane drivers had about 21% higher speed reduction than closed lane drivers.

## 3.7 Conclusions

This study was successful in identifying the effectiveness of safety measures in various work zones with different characteristics. The PELT algorithm in multiple

changepoint analysis effectively developed models to detect driver's interactions with a series of safety features in a variety of work zones with different traffic control plans.

There was a higher speed variations for lane closure and speed reduction scenarios. However, the magnitude of dispersion depended on the safety measures layout. It also displayed less variation for the case of lane closure with no speed reductions and even lower variations for the shoulder closures and lane shift scenarios with no speed reductions. Male drivers' median speed was higher than that for female drivers. The median speed was also higher in closed lane when compared to open lane traces, particularly when there was no lane closures in work zones. Some of the speed dispersion could be explained by lane closures and speed reductions.

The model of a work zone with lane closure and no speed reduction proved to be very effective in getting drivers' attention. Drivers were shown to adapt their speed based on their risk perception. The low number of safety measures in combination with no speed reduction caused substantially less speed variation and effective speed reduction. Also, having very low work zone speed limit was not effective in slowing the traffic down at the upstream and continuing to the taper area.

The results of all different work zones changepoint models revealed female drivers overall had slightly higher reactions to the safety measures applied from the first warning sign up to the taper location compared to male drivers. It was also observed that closed lane drivers were less reactive to the safety features applied prior to the taper area. The exceptions were DSFS and DMS when located closer to the taper area.

This study found static warning signs are not effective in getting driver's attention unless it was combined with a DMS. However, the effect of a DMS are more pronounced

when they are applied closer to the taper area. The DSFS in combination with the first warning sign were found to be the most effective safety features to attract drivers' attention to slow down in work zones. The combinations of first warning sign and DSFS along with flashing arrow, tapering and channelization had the highest combined effect in reducing traffic speed in the work zone by as much as 40%.

The study also found that the longer distance between the first and second work zone warning signs, with no indication of work zone activities in between, caused drivers to eventually ignore the signs and increase their speed. This in turn may affect the credibility of work zone warning signs.

The findings of this research, based on observations of changepoint models, suggest applying more efficient safety features, such as DSFS and DMS in closer proximity to the taper area are very effective to capture driver's attention to slow down in work zones. The presence of DSFS on both side of the roadway may be more effective to get outside lane drivers to slow down earlier prior to the taper location. The large distance between the warning signs with no activity causes drivers ignore the sign and maintain their upstream speed. The combination of work zone warning signs with the attached advisory speed plate and the DSFS at 2,640 and 2,100 feet upstream of the taper location was a very successful safety strategy to slow the traffic before reaching to the taper area.

It was desired to find the effectiveness of any individual safety feature in work zones, however the proximity of safety features caused the changepoint model to detect the combined effects of the features. This will be addressed by using the methods of functional data analysis to convert the discrete observations to functional data and smoothing the noises. The smoothed data can be utilized to observe the speed of vehicle at a desired distance to any

safety measure and identify if the safety measure had a significant influence on drivers to slow down in the work zone. The effectiveness of any individual safety feature, which could not be detected by changepoint models, will be investigated in the next chapter.

### 3.7.1 Limitations

The study constraint was the low number of work zones with similar configurations and TTCD layout. Even work zones with identical safety features layout had different locations for the placement of safety features in regard to the taper location. Since this was the naturalistic driving in a natural environment, we had no control over the work zone configurations and safety measures layout unlike the experimental setups. The larger sample size is always preferred to minimize the effects of outliers. Having a higher number of traces for all work zone configurations and all sub-groups of data would help to give more statistical power to our study results.

Although the PELT multiple changepoint package is an exact method utilized to accurately and efficiently detect changepoints, it has some drawbacks due to the requirement of a manual penalty to avoid over/under-fitting. Therefore, selecting the appropriate penalty may be subjective. The appropriate value, however, can be selected by conducting a sensitivity analysis through testing different penalty values until finding the one that looks appropriate for the dataset and problem in hand.

## 3.8 References

1. National Work Zone Safety Information Clearinghouse. Traffic Crashes in Work Zones. <https://www.workzonesafety.org/crash-information/workzone-fatalities/workzone-fatalitiesmotor-vehicle-traffic-crashes-2014/>. Accessed November 2016.

2. Hong Young, H, Ozturk, O., Ozbay, K., and Xie, K. Work Zone Safety Analysis and Modeling: A State-of-the-Art Review. Transportation Research Board, Washington D.C., January 2014.
3. Wang, J., Hughes, W. E., Council, F. M., and Paniati, J. F. Investigation of Highway Work Zone Crashes: What We Know and What We Don't Know. Transportation Research Record: Journal of the Transportation Research Board No. 1529, pp. 54-62, 1996.
4. Yang, H., Ozbay, K., Ozturk, O., and Yildirimoglu, M. Modeling Work Zone Crash Frequency by Quantifying Measurement Errors in Work Zone Length. Accident Analysis & Prevention 29 55(June), pp. 192-201, 2013.
5. Chandler, B., Kehoe, N., O'Donnell, C., Luttrell, T., and Perry, E. Work Zone Safety Data Collection and Analysis Guide. Report for FHWA. American Traffic Safety Services Association, 39 Fredericksburg, Virginia, 2013.
6. Dingus, T. A., Hankey, J. M., Antin, J. F., Lee, S. E., Eichelberger, L., Stulce, K., McGraw, D., Perez, M., Stowe, L. Naturalistic Driving Study: Technical Coordination and Quality Control. Virginia Tech Transportation Institute. Blacksburg, VA, 2014.
7. Smadi, O. SHRP 2 S-04A Roadway Information Database Development and Technical Coordination and Quality Assurance of the Mobile Data Collection Project. Presented at the 7th SHRP 2 Safety Research Symposium, Washington D.C., 2012.
8. Traffic Safety Facts 2008. National Highway Traffic Safety Administration. Report No. DOT HS 810 631, U.S. Department of Transportation, Washington, D.C., 2009.
9. Federal Highway Administration. Facts and Statistics – Work Zone Safety. Retrieved on August 28, 2017, [https://ops.fhwa.dot.gov/wz/resources/facts\\_stats/safety.htm](https://ops.fhwa.dot.gov/wz/resources/facts_stats/safety.htm)
10. Li, Y., Bai, Y. Highway Work Zone Risk Factors and Their Impact on Crash Severity. Journal of Transportation Engineering, 135(10), pp. 694–701, 2009.
11. Dissanayake, S., Akepati, S. R. Identification of Work Zone Crash Characteristics. Final Report. Department of Civil Engineering, Kansas State University, 2009.
12. Outcalt, W. S. Work Zone Speed Control. Colorado Department of Transportation, DTD Applied Research and Innovation Branch, 2009.
13. Fitzsimmons, E., Oneyar, N., Hallmark, S., Hawkins, N., and Maze, T. Synthesis of Traffic Calming Techniques in Work Zones, Final Report, January 2009.

14. Garber, N. J., and Patel, S. T. Control of Vehicle Speeds in Temporary Traffic Control Zones (Work Zones) Using Changeable Message Signs with Radar. In Transportation Research Record 1509. TRB, National Research Council, Washington, D.C., 1995.
15. Shaik, N. M., Sanford Bernhardt, K. L., and Virkler, M. R. Evaluation of Three Supplementary Traffic Control Measures for Freeway Work Zones. Mid-Continent Transportation Symposium Proceedings, Iowa State University, Ames, Iowa, May 2000.
16. Maze, T., Kamyab, A., and Schrock, S. Evaluation of work zone speed reduction measures, CTRE Management Project 99-44, Iowa Department of Transportation, April 2000.
17. Sommers, N. M., and McAvoy, D. S. Improving Work Zone Safety through Speed Management. Ohio State University, June 2013.
18. Garber, N. J. and Patel, S. T. Effectiveness of Changeable Message Signs in Controlling Vehicles Speeds in Work Zones Report No. VTRC 95-R4. Virginia Transportation Research Council, Charlottesville, Virginia, 1994.
19. Brewer, M. A., Pesti, G., and Schneider, W. IV (2006). "Improving Compliance with Work Zone Speed Limits: Effectiveness of Selected Devices." Transportation Research Record 1948. Transportation Research Board, Washington, D.C., pp. 67–76.
20. Zech, W. C. and Mohan, S. B. Evaluation of Messages on Changeable Message Signs as a Speed Control Measure in Highway Work Zones. Practical periodical on Structural Design and Construction 13(1), ASCE, pp.11-18, 2008.
21. Li, Y., & Bai, Y. Determining the optimal deployment location of portable changeable message signs in the upstream of work zones, 2011.
22. McCoy, P.T., Bonneson, J. A., and Kollbaum, J. A. Speed Reduction Effects of Speed Monitoring Displays with Radar in Work Zones on Interstate Highways. Transportation Research Record, No. 1509, pp. 65-72. Transportation Research Board, Washington D.C., 1995.
23. Pesti, G. and McCoy, P. T. Long Term Effectiveness of Speed Monitoring Displays in Work Zones on Rural Interstate Highways", Paper No. 01-2789, Transportation Research Board, Washington D.C., 2001.
24. Hallmark, S. and Hawkins, N. Dynamic Speed Feedback Sign. Institute for Transportation, Iowa State University, October 2014.

25. Carlson, P.J., et al., Evaluation of Traffic Control Devices for Rural High-Speed Maintenance Work Zones, Texas A&M University–Texas Transportation Institute, College Station, 2000
26. McCoy, P.T. and G. Pesti, G. Effectiveness of Condition-Responsive Advisory Speed Messages in Rural Freeway Work Zones. *Transportation Research Record*, No. 1794, pp. 11–18, Transportation Research Board Washington, D.C., 2002.
27. Hajbabaie, A., Medina, J., Wang, M. H., Benekohal, R., and Chitturi, M. Sustained and Halo Effects of Various Speed Reduction Treatments in Highway Work Zones. *Transportation Research Record*, No. 2265, pp. 118–128 Transportation Research Board, Washington, D.C., 2011.
28. Pesti, G. and P.T. McCoy. Effect of Speed Monitoring Displays on Entry Ramp Speeds at Rural Freeway Interchanges. *TRB 2002 Annual Meeting CD-ROM*, Paper No. 02-2571, TRB, National Research Council, Washington, D.C., 2002.
29. Benekohal, R., Wang, M., Chitturi, M., Hajbabaie, A., and Medina, J. Speed Photo-Radar Enforcement and Its Effects on Speeds in Work Zones, 2008.
30. Eckley, I. A., Fearnhead, P., and Killick, R. Analysis of changepoint models. In Barber, D., Cemgil, T., and Chiappa, S., editors, *Bayesian Time Series Models*. Cambridge University Press, 2011.
31. Killick, R., and Eckley I. A. “changepoint: An R Package for Changepoint Analysis.” *Journal of Statistical Software*, 58(3), 1–19, 2014.
32. Killick, R., Fearnhead, P., and Eckley I. A. “Optimal Detection of Changepoints with a Linear Computational Cost.” *Journal of the American Statistical Association*, 107(500), 1590–1598, 2012.
33. Yang, M. H., Luong, T. T. B., Recker, W. Extracting traffic patterns from loop detector data using multiple changepoint detection, 2014.
34. Scott, A. J., and Knott, M. “A Cluster Analysis Method for Grouping Means in the Analysis of Variance.” *Biometrics*, 30(3), 507–512, 1974.
35. Sen, A., Srivastava, M. S. “On Tests for Detecting Change in Mean.” *The Annals of Statistics*, 3(1), 98–108, 1975.
36. Auger, I. E. and Lawrence, C. E. Algorithms for the optimal identification of segment neighborhoods. *Bulletin of Mathematical Biology*, 51(1):39–54, 1989.

37. Bai, J. and Perron, P. Estimating and testing linear models with multiple structural changes. *Econometrica*, 66(1):47–78, 1998.
38. Killick, R., and Eckley, I. A. *Changepoint: an R package for changepoint analysis*. Lancaster University, 2013.
39. Hilde E. D. and Mason D. D. Effectiveness of countermeasures to reduce vehicle speeds in freeway work zones. *Canadian Journal of Civil Engineering*, Vol. 41, 2014
40. Federal Highway Administration (FHWA), *Manual on Uniform Traffic Control Devices for Streets and Highways*, 2009.  
<https://mutcd.fhwa.dot.gov/htm/2009/part6/part6h.htm>



### 3.9 Appendix 3: Speed Profile Distributions

#### Left Lane Closure with a DMS after Lane Merge Sign

- Overall traces

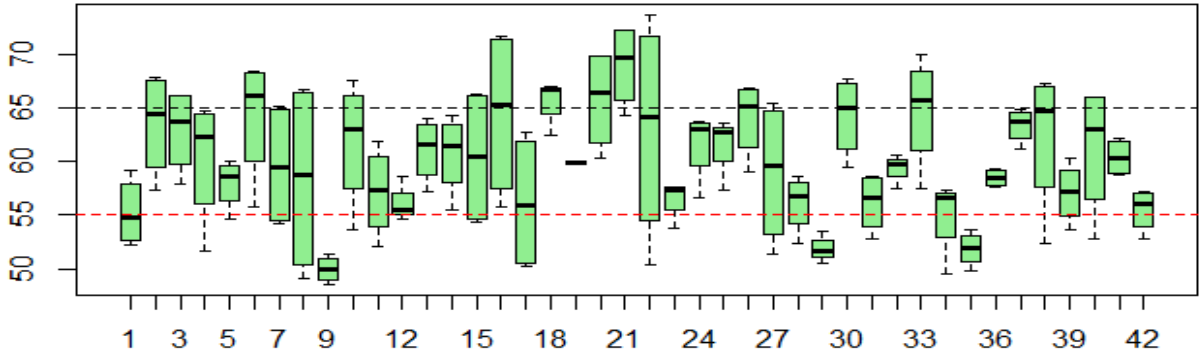

- Male drivers' traces

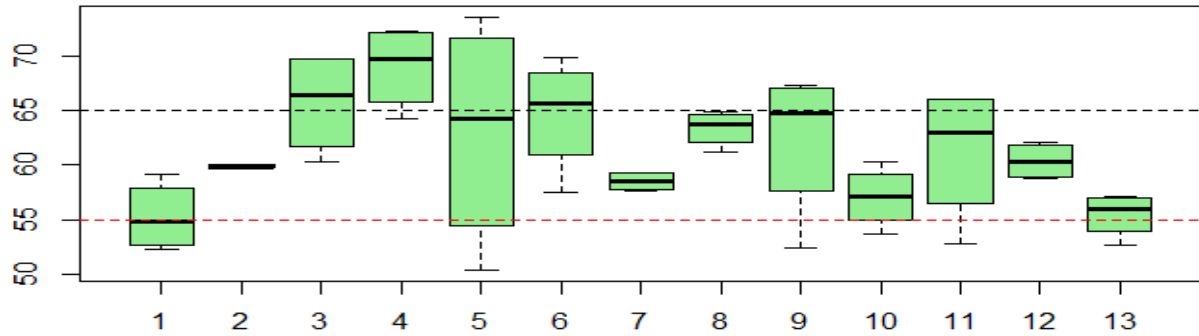

- Female drivers' traces

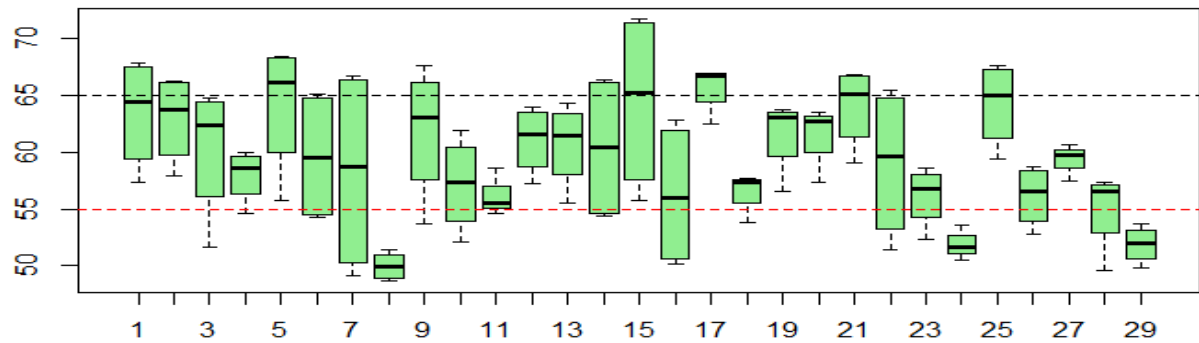

- Closed lane traces

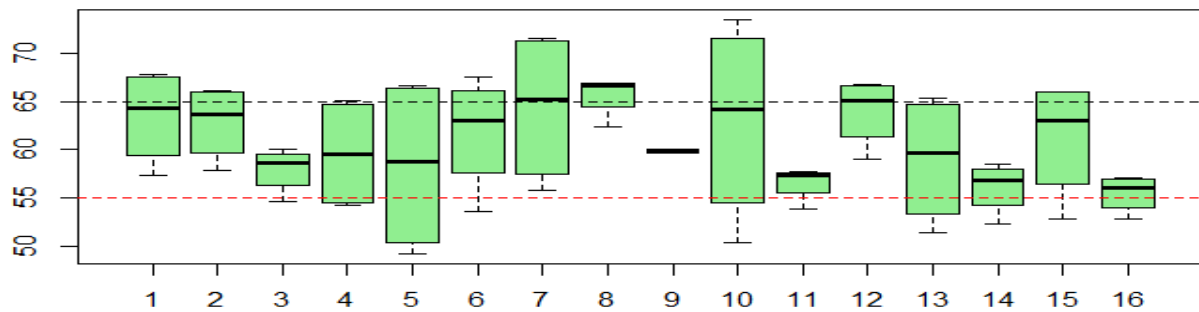

- Open lane traces

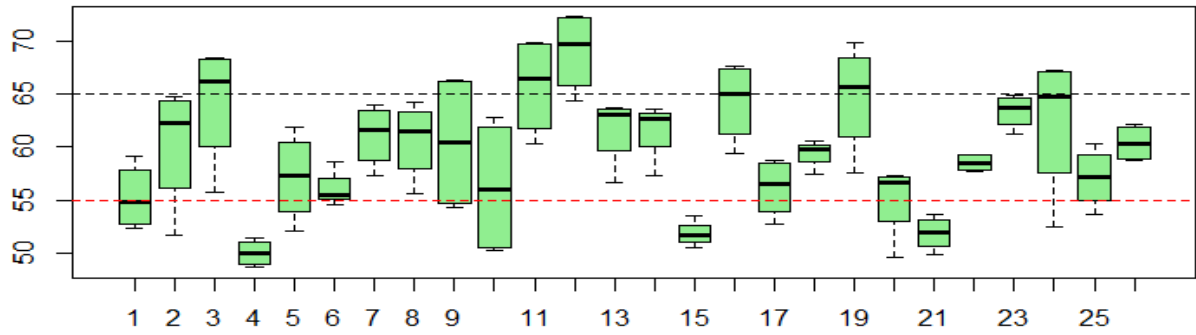

**Left Lane Closure with a DSFS after 1<sup>st</sup> Work Zone Warning Sign**

- Overall traces

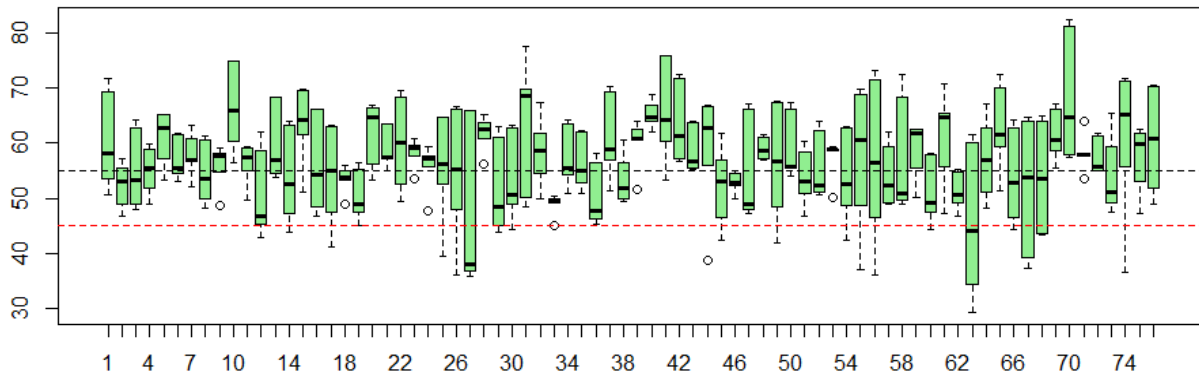

- Male drivers' traces

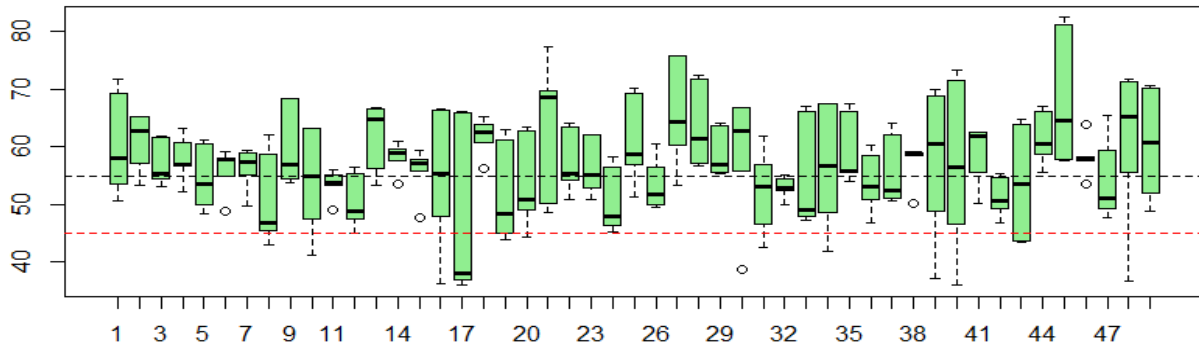

- Female drivers' traces

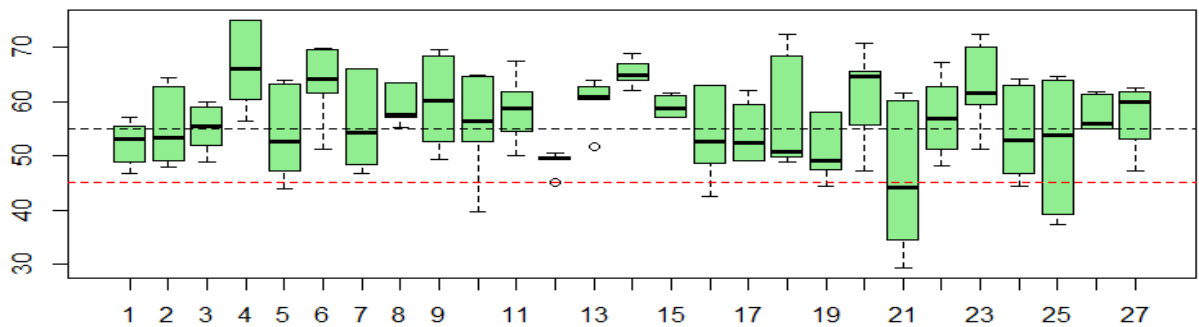

- Closed lane traces

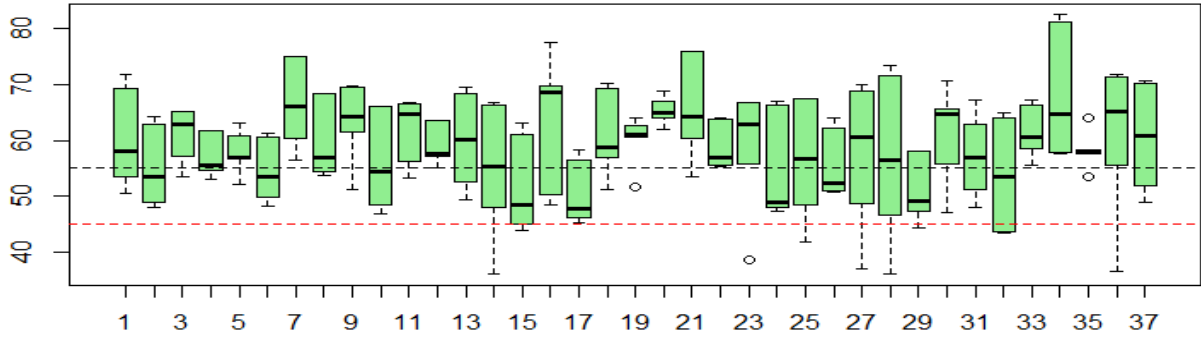

- Open lane traces

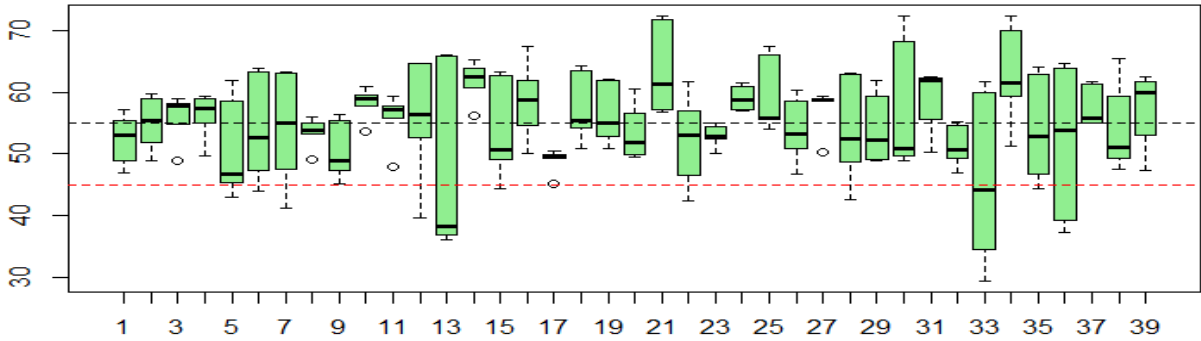

**Left Lane Closure on multi-lane divided rural highway**

- Overall traces

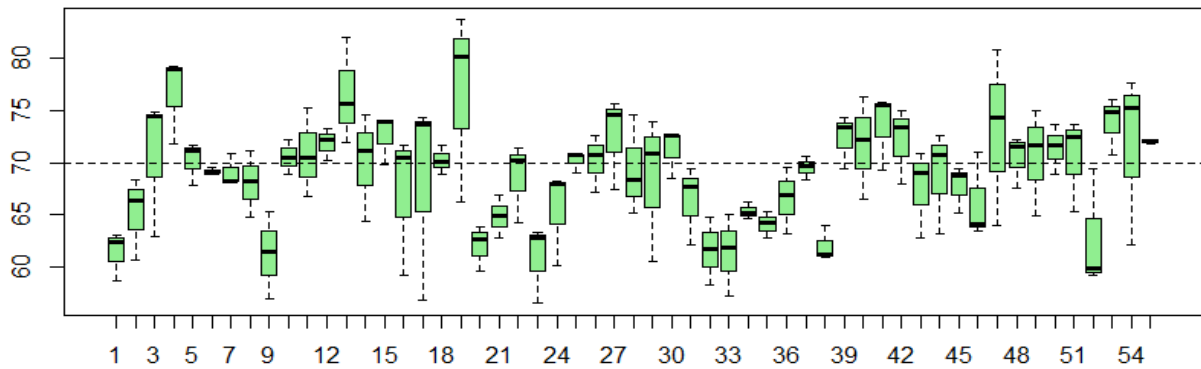

- Male drivers' traces

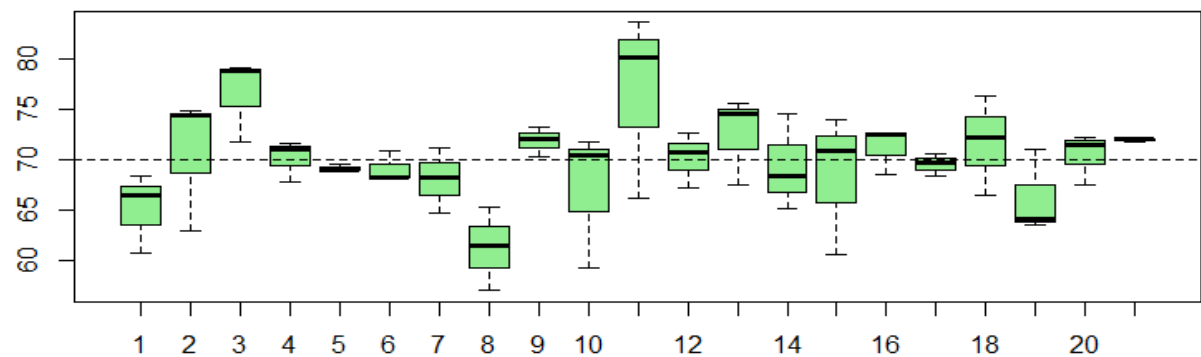

- Female drivers' traces

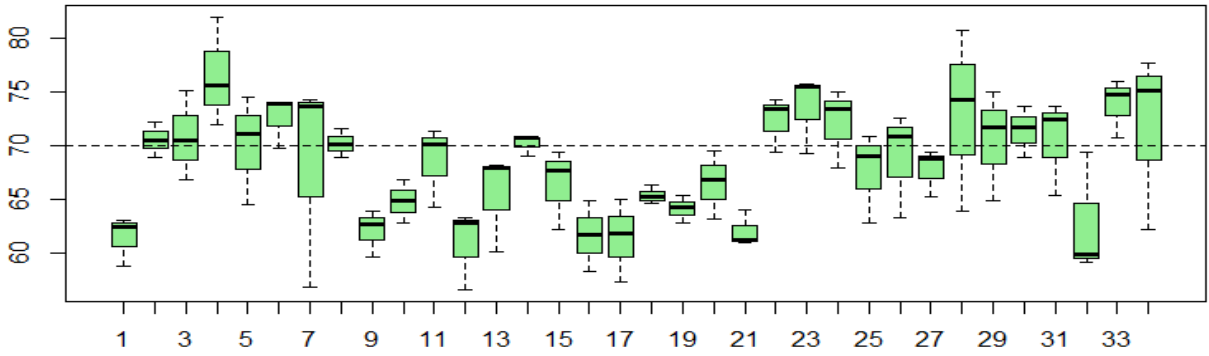

- Closed lane traces

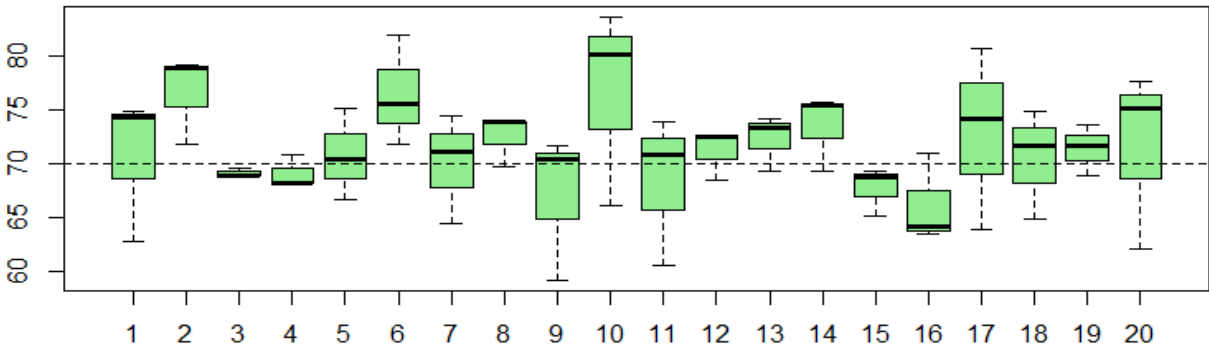

- Open lane traces

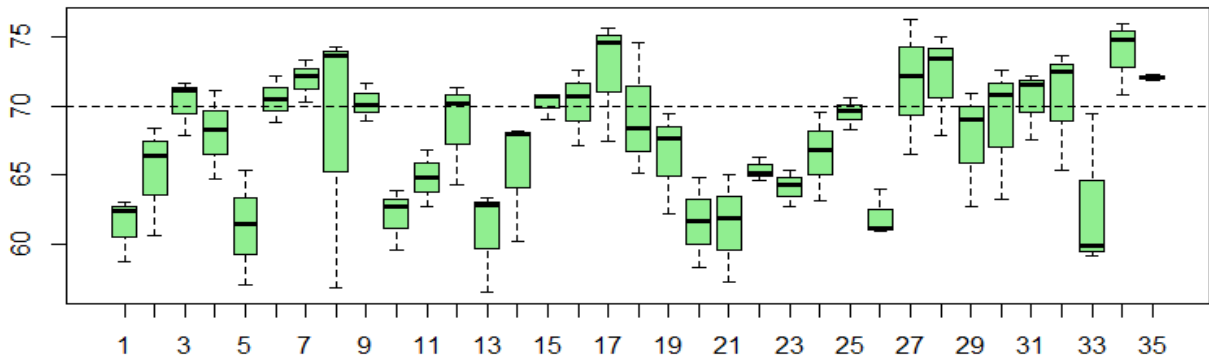

**Right Lane Closure with DSFS after Work Zone 1<sup>st</sup> Warning Sign**

- Overall traces

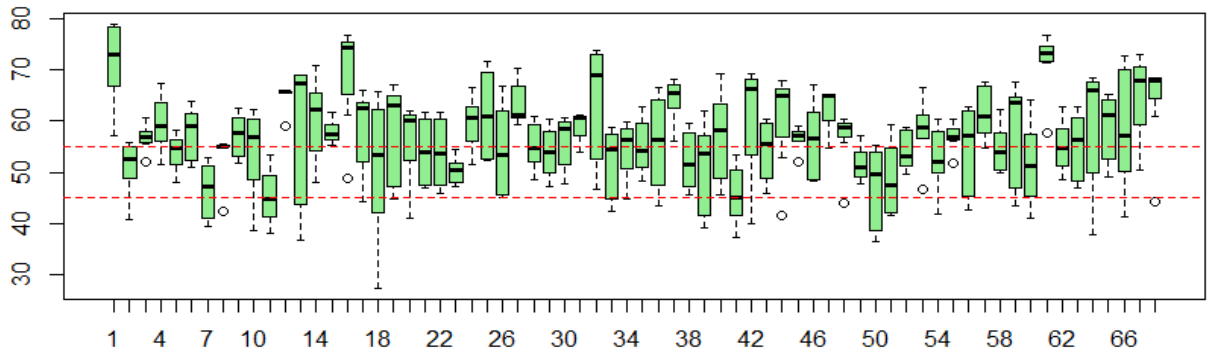

- Male drivers' traces

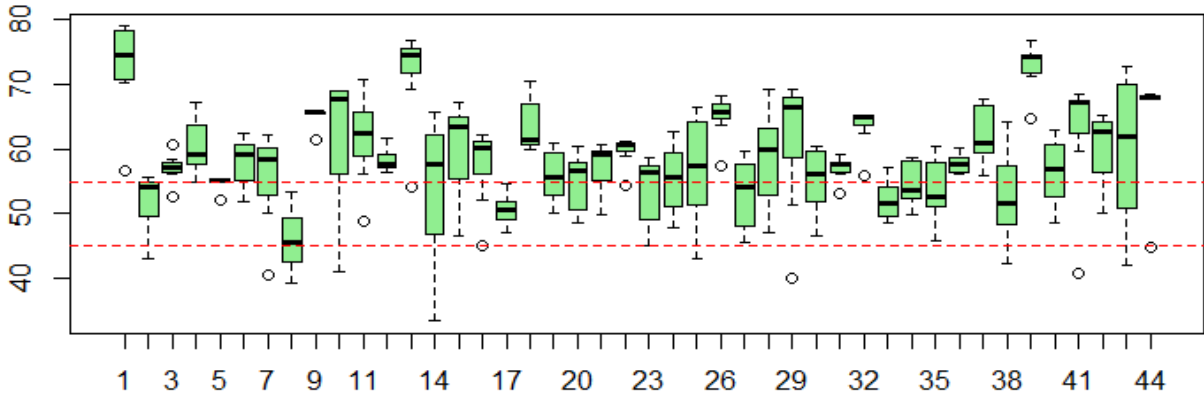

- Female drivers' traces

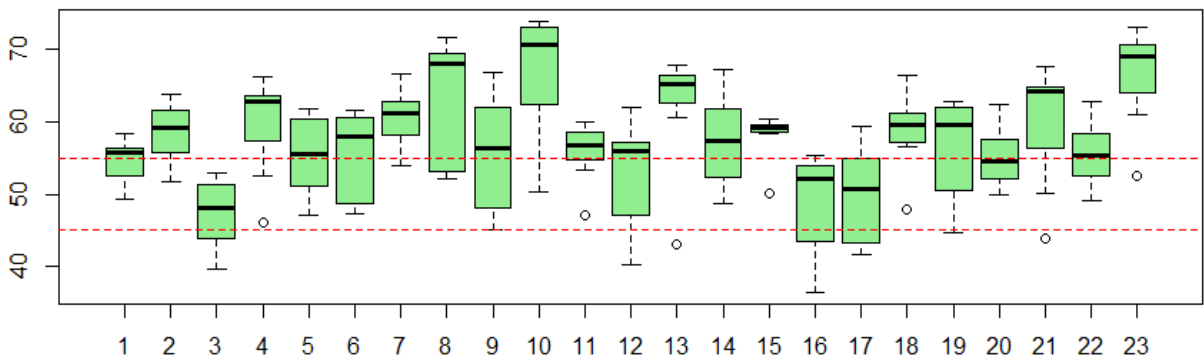

- Closed lane traces

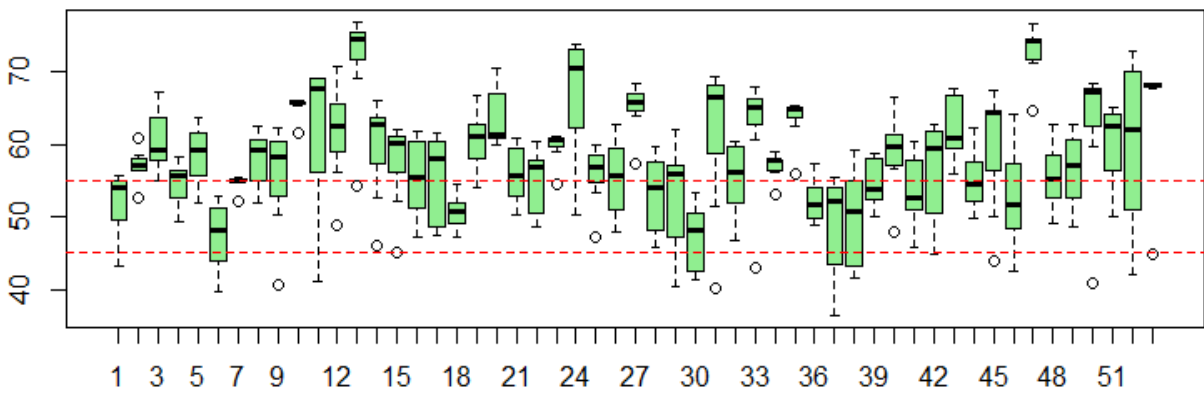

- Open lane traces

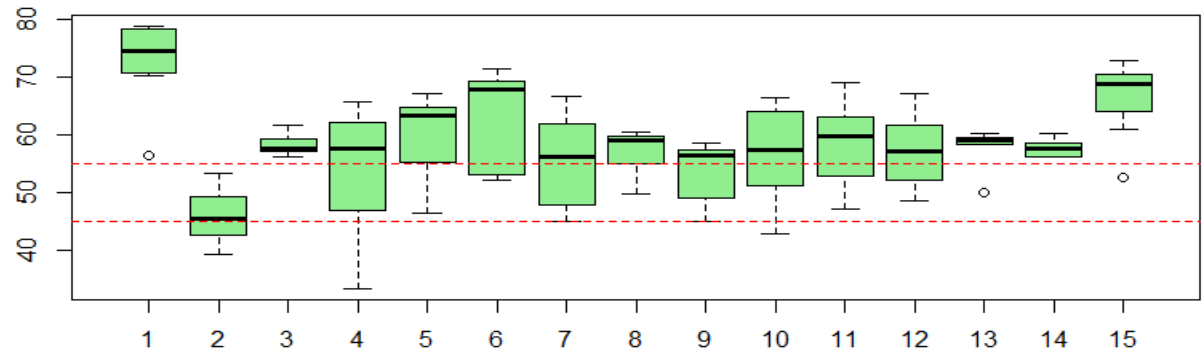

**Left Shoulder Closed**

- Overall traces

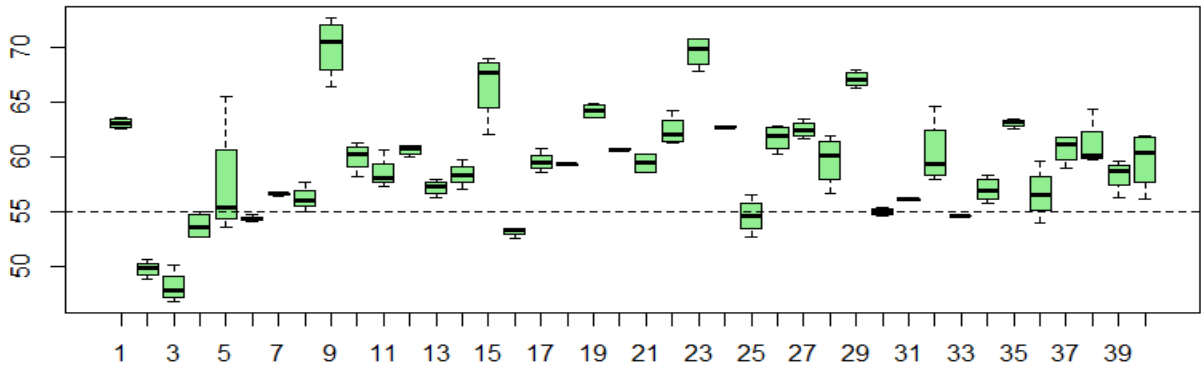

- Male drivers' traces

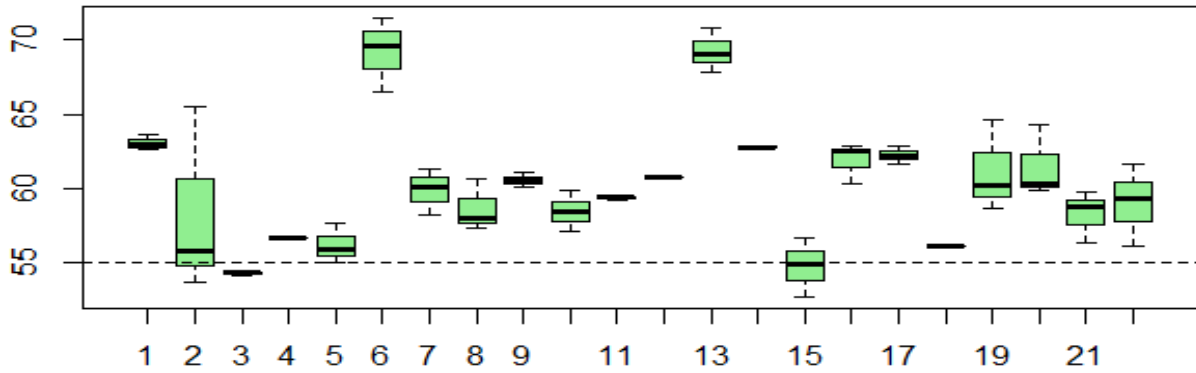

- Female drivers' traces

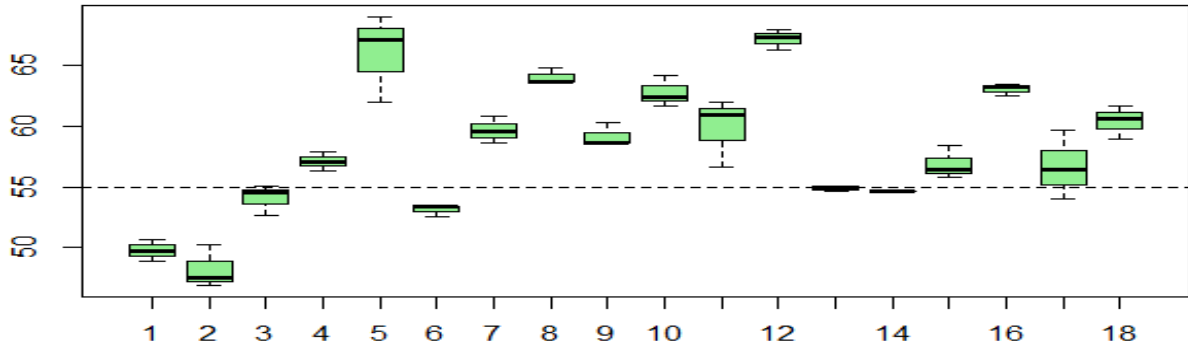

- Outside lane traces

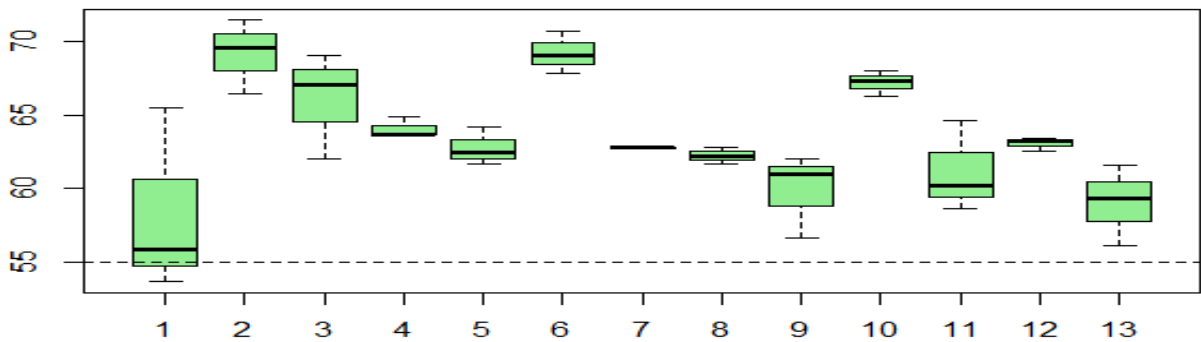

- Inside lane traces

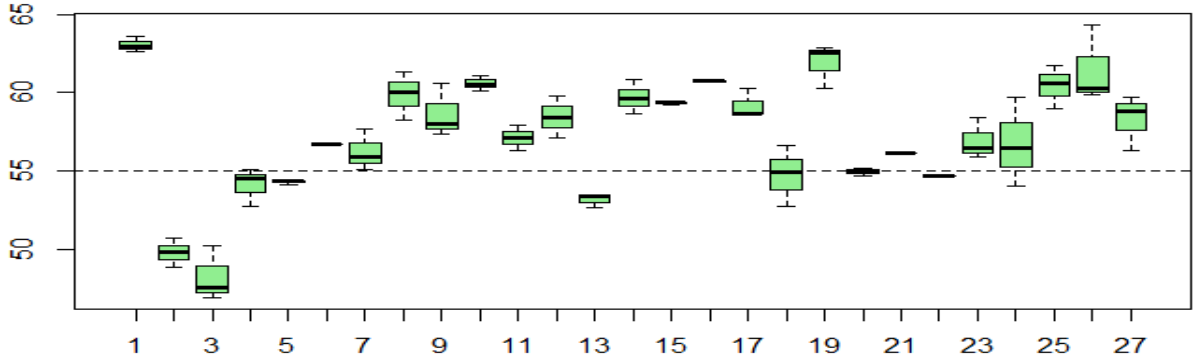

**Right Shoulder Closed**

- Overall traces

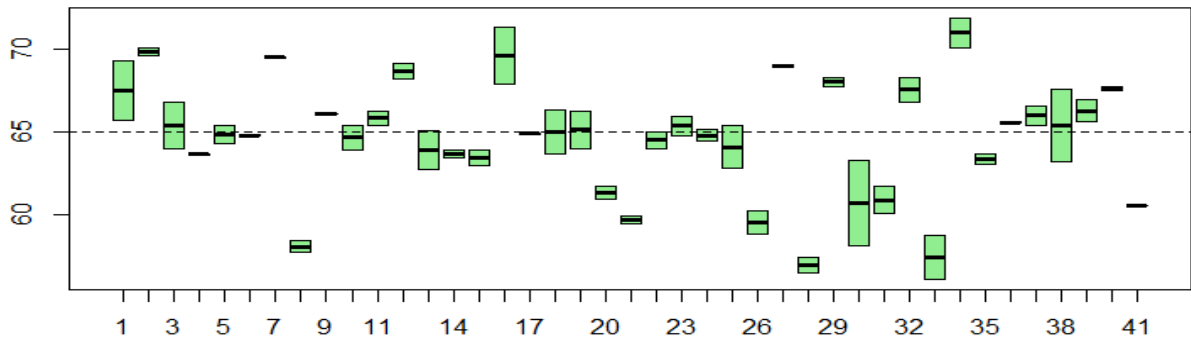

- Male drivers' traces

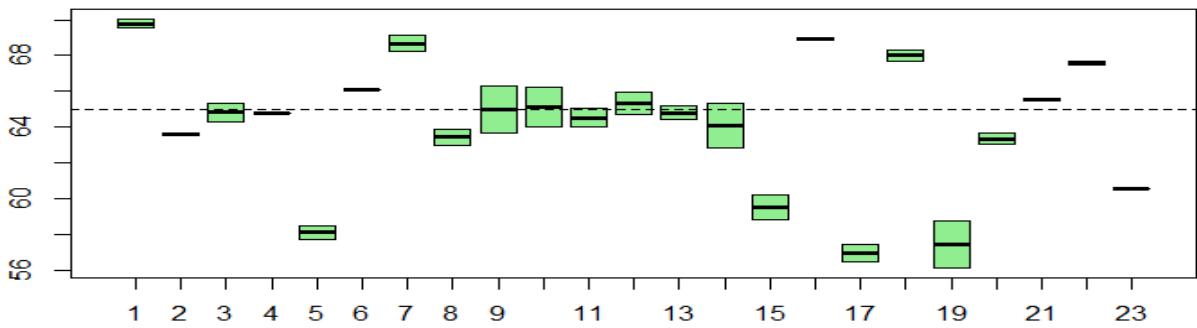

- Female drivers' traces

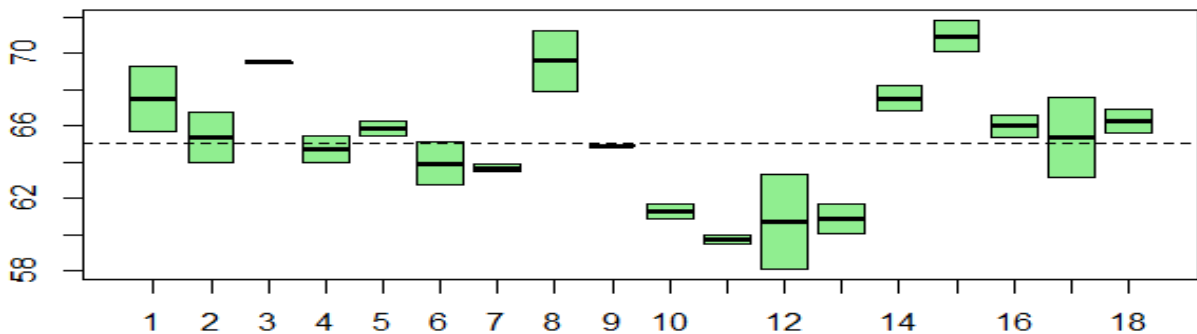

- Outside lane traces

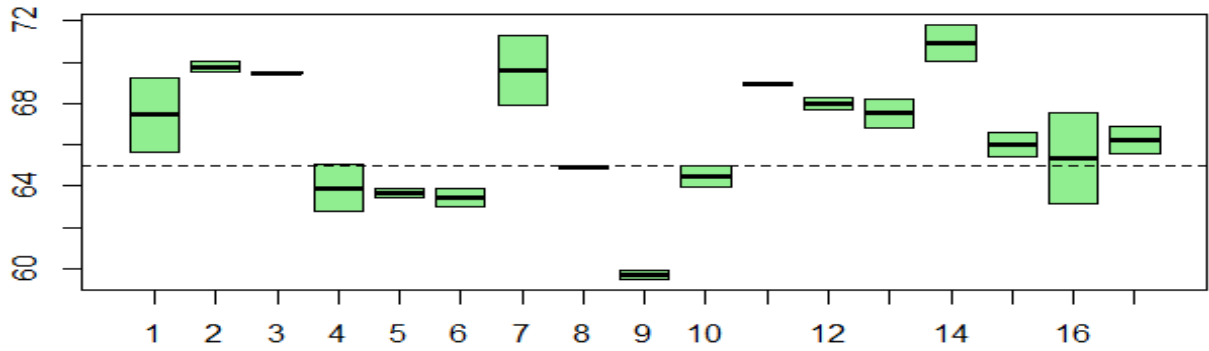

- Inside lane traces

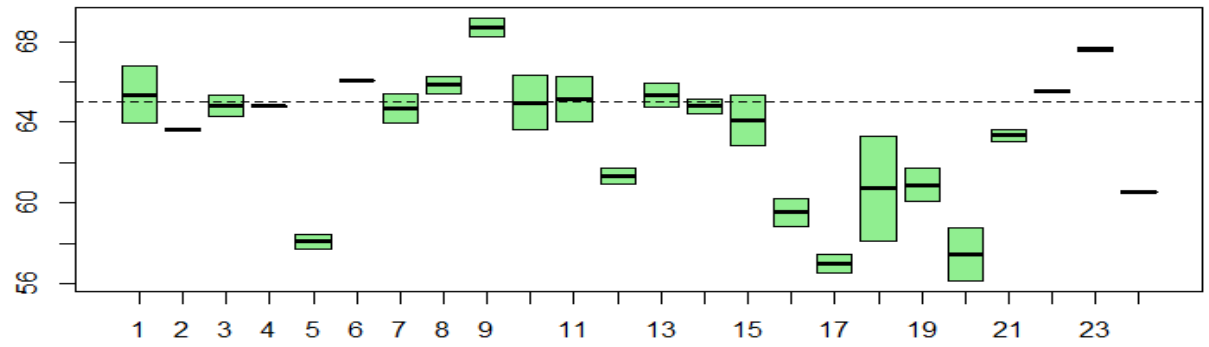

**Both Shoulder Closed**

- Overall traces

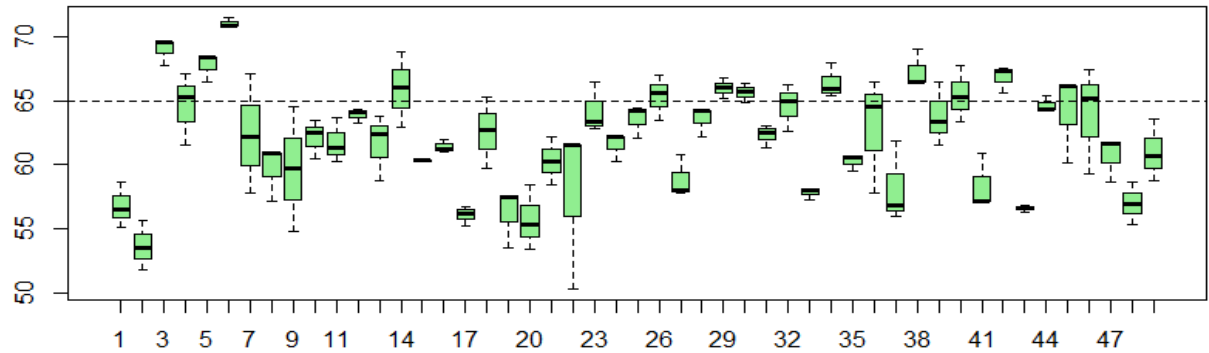

- Male drivers' traces

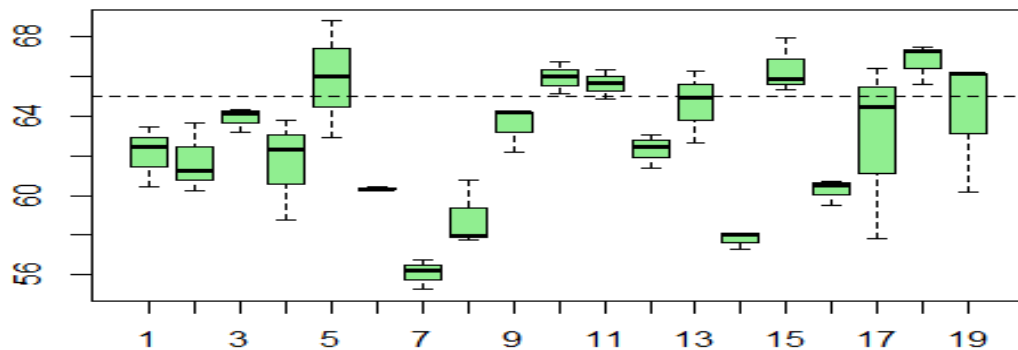



- Female drivers' traces

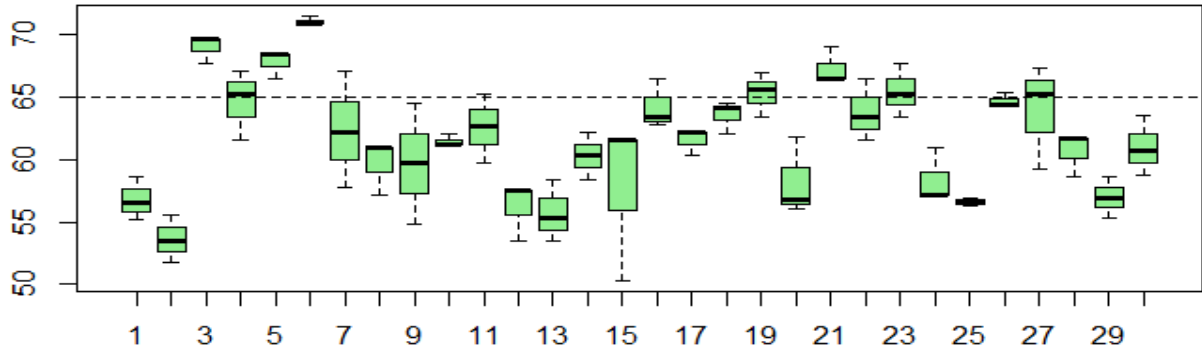

- Outside lane traces

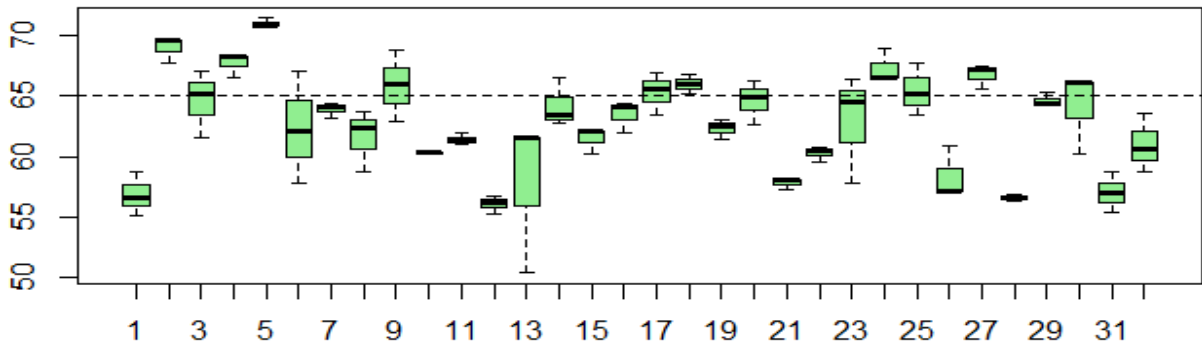

- Inside lane traces

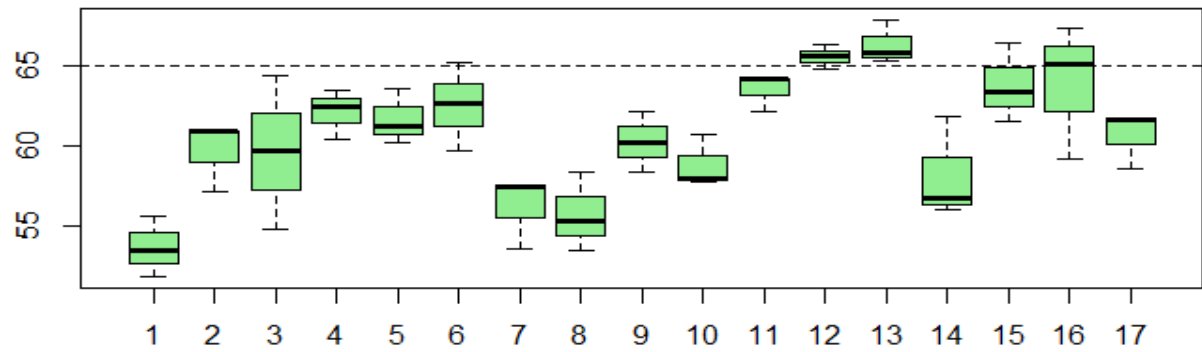

**Lane Shift**

- Overall traces

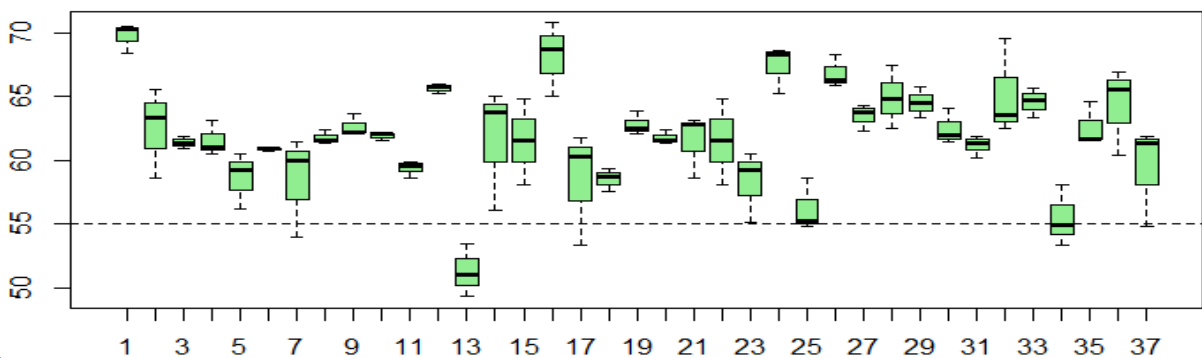

- Male drivers' traces

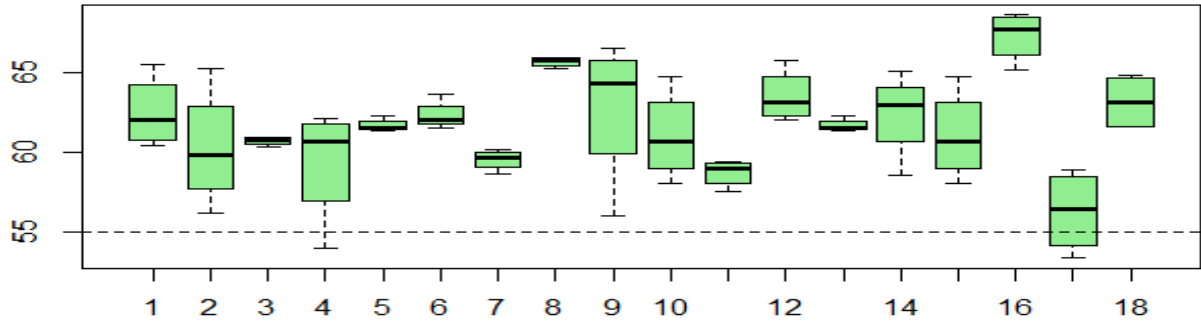

- Female drivers' traces

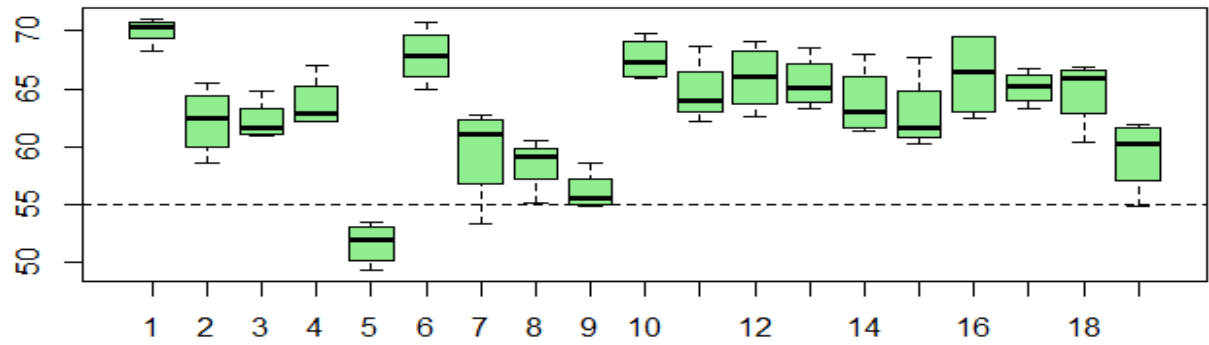

- Outside lane traces

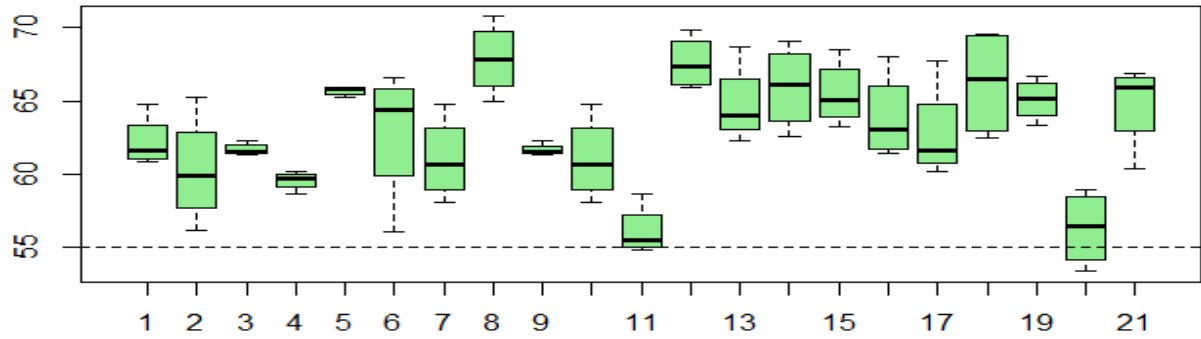

- Inside lane traces

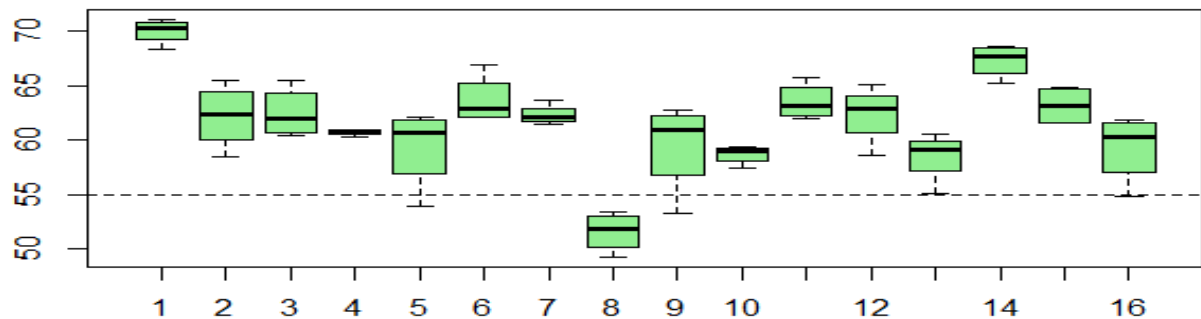

## **CHAPTER 4. DRIVER BEHAVIOR STUDY BY FUNCTIONAL DATA ANALYSIS OF SPEED PROFILES IN WORK ZONES USING SHRP 2 NATURALISTIC DRIVING STUDY DATA**

Modified from a paper to be submitted to the *Transportation Research Record*  
Hossein Naraghi and Omar Smadi

### **Abstract**

The dynamic of highway work zones create a constantly changing environment with varying level of risk that elevates the safety hazards. There was an increase of about 11% in work zone-related fatalities from 2010 to 2014 despite a small decrease in non-work zone-related fatalities in the U.S. (1). Work zone safety is a major concern for construction workers, the travelling publics, and transportation safety agencies. Work zone impacts on safety creates a strong need to protect road users and construction workers.

Speeding and speed variations are considered to be major unsafe driver behaviors that elevate the safety risks in the work zone. The Federal Highway Administration (FHWA) crash facts indicate speeding as a contributing factor to 28% of work zone crashes in 2014. A series of countermeasures have been used to get drivers' attention to comply with work zone conditions and reduce their speed. There is limited information about which safety features are the most effective in encouraging drivers to slow down in work zones.

The features of functional data analysis were utilized to summarize driver behavior by analyzing speed time series data from SHRP 2 NDS. The main objective of the analysis is to identify the effectiveness of every countermeasure utilized in the work zone to encourage safe driving. Various safety measures such as static warning signs, the DMS, the DSFS, and other similar signs were investigated. The effectiveness measured over five work zones, four with lane closures and one with a lane shift scenarios. An overall model was created for each work zone which was further broken down to individual models involving male, female,

open lane, and closed lane drivers to observe similarity and differences between each comparable group.

The speed trajectory time series data from the SHRP 2 NDS work zones at a rate of 0.1 seconds (10 HZ) were used to study driver behavior associated with various safety features applied in work zones. The functional data created opportunities to find mean speed and speed variations at a legible distance upstream of the safety measures. The change in mean speed in reaction to the applied safety feature was calculated to learn if it was significantly effective in reducing speed. Also, the speed variability associated with each safety measure was measured to observe the effect of the safety feature on speed variability.

## **4.1 Introduction**

### **4.1.1 Background**

The presence of a work zone increases disturbance to traffic flow and produce a high cognitive work load for drivers and heightening safety risks. According to the National Work Zone Safety Clearinghouse, there was an increase of about 11% in work zone-related fatalities from 2010 to 2014 despite a small decrease in non-work zone-related fatalities in the U.S. (1). Work zone safety is a major concern for construction workers, the travelling publics, and transportation safety professionals. Work zone impacts on safety creates a strong need to protect road users and construction workers.

As previous research revealed, there are a large number of factors associated with work zone safety, but it is mainly concluded that speeding and distractions are the main risky driver behaviors in work zones. Several studies identified human factors as the major contributing factor to nearly 93% of all crashes (Rumar et al., Salmon et al. 2005, NHTSA 2015). Although driver behavior has contributed significantly to crashes, it is the least

understood factor attributed to crash causation. This is mainly due to limited information about driver behavior in our traditional crash data.

The Strategic Highway Research Program 2 Naturalistic Driving Study (SHRP 2 NDS) along with the Roadway Information Database (RID) provided a unique opportunity to better understand the role of driver behavior in work zone crashes. The speed time series data from SHRP 2 NDS can be visualized and analyzed to identify when and where drivers start to react to the presence of safety features in work zones. The existence of the speed time series data provided an opportunity, but finding an appropriate and well-established statistical method to analyze them is a major challenge.

#### **4.1.2 Background on SHRP 2 Naturalistic Driving Study**

The SHRP 2 NDS is the largest and most comprehensive driving-based research study ever conducted. NDS is designed to observe driver's daily driving behavior in a natural setting environment with no experimental control. The Virginia Tech Transportation Institute (VTTI) led this project implementation and coordination. More than 3000 female and male drivers aged 16 to 98 were recruited in six unique and geographically distributed sites (New York, Florida, Washington, North Carolina, Indiana, and Pennsylvania). The participants' vehicles were equipped with the Data Acquisition System (DAS), consisting of sensors, cameras, a Geographic Positioning System (GPS), a vehicle network, a lane tracking system, accelerometers, an eye-tracking system, and data storage. The DAS sensors collected data such as speed, GPS, and acceleration while the four cameras collected forward, rear, driver face, and over the shoulder videos. Over 3,100 drivers made over 5 million trips over the two-year study period resulted in more than 30 million data miles and 4 million gigabytes of data. The NDS collected a variety of variables regarding drivers' daily driving behavior

without any experimental control. Most of the variables were collected at high frequency (10 HZ), which is every 0.1 second (6).

#### **4.1.3 Background on SHRP 2 Roadway Information Database**

The Roadway Information Database (RID) was conducted to collect roadway information data for the roads driven by drivers in the SHRP 2 NDS. The Center for Transportation Research and Education (CTRE) at Iowa State University led the implementation and coordination of the project, which used mobile data collection vans to collect about 12,500 center line miles of roadway data elements in the six NDS sites. In addition, other existing roadway data from government, public and private sources, as well as supplemental data, were utilized to populate a roadway element dataset linkable to NDS trips to support a comprehensive safety assessment of driver behavior. The identified roadway data elements included information on roadway alignment, number of lanes, lane type and width, intersection types and location, lighting, signage, median type, barriers, rumble strips, and other features. The RID integrated 511 data provided by the states with roadway data collected throughout the NDS study locations. The integrated 511 data was the primary source of identifying work zone locations and duration (7).

The advancement of data collection technologies permitted dense observations over time and space. The densely collected data, such as speed time series data from SHRP 2 NDS collected at 10 HZ (every 0.1 second), reflect the influence of smooth functions as the underlying process generating observations. The collection of individual speed profiles creates a large volume of data require use of appropriate methods. The classical multivariate statistical methods can be used to analyze speed time series data. The classical methods cannot utilize the additional information provided by smoothness of underlying functions.

The functional analysis methods can take advantage of the additional information existing in the functions and their derivatives, which cannot be utilized by traditional statistical analysis. As Levitin et al. stated, “New types of data require new tools for analysis” (4).

#### **4.1.4 Background on Functional Data Analysis (FDA)**

Collected data with high sampling rates creates high-dimensional vectors so the classical statistical approaches become inadequate methods of analysis due to the functional nature of the data and the significant correlation between close observations. Functional Data Analysis (FDA) is a statistical field, which has mainly evolved over the last two decades that appears in several research disciplines such as economics, medical fields, psychology, mereology, and others. The overview of FDA can be found mainly in the reference books of Ramsay et al. (2002, 2005), and other sources (4-8). The FDA tools can be utilized to understand the variations in the underlying process over a group of repeated observations. It can be used to better analyze and model high dimensional and complex time series data collected at a high frequency (Ramsay et al., 2005).

The FDA is the analysis of information on functions or curves, and is a collection of statistical methods to answer questions such as:

- How the speed functions are different from one driver trace to another trace in a work zone?
- What are the main elements of variations of the speed functions from one trace to another?

It can be concluded that FDA is definitely a suitable method for analyzing speed time series profiles in work zones as part of SHRP 2 NDS collected at high frequency 10 HZ (every 0.1 second). Due to the complex process of driver behavior, the traditional multivariate statistical

methods are not capable of extracting the crucial information supplied by the smoothness of underlying functions.

## 4.2 Literature Review

Limited research has been conducted to develop models on the effectiveness of safety features in work zones. Work zones create change in traffic patterns requiring speed reductions. The proper usage and placement of safety features and traffic control devices are an important part of every work zone management plan where the safety of construction workers, as well as the traveling public, is the major concern for safety professionals. The National Highway Transportation Safety Administration (NHTSA) identified speeding as the major contributing factor in 30 percent of fatalities (8). The FHWA crash facts also indicated speeding as a contributing factor to 28% of work zone crashes in 2014 (9), thus speeding is clearly a major contributing factor (10, 11). This has raised awareness of the negative effects of speeding in work zones, which has increased the emphasis placed on reducing speed and enforcing compliance with work zone speed limits. In order to determine the impact of safety measures on attracting drivers' attention and reducing vehicle speed, a literature review has been conducted to summarize the major findings associated with speed management in work zones.

Past research reveals that the use of signs to reduce the speed of traffic through work zones has different ranges of effectiveness. It can depend on factors such as geometry, sight distance, and the posted speed limit in a work zone location (12). The effectiveness of speed reduction signs also varies, but can mainly be attributed to driver behavior, which has not been truly investigated.



Research in identifying the effectiveness of traffic control devices in work zones indicates the most effective measures in reducing mean speed and speed variance are speed display signs, flaggers, and automated radar detections with citations issued to vehicle owners who exceed the limit. On the other hand, pavement markings, signs, and other standard traffic control devices were found to be ineffective in reducing vehicle speed in work zones (13-17).

Studies on the effectiveness of Changeable Message Signs (CMS) in reducing speeds and informing traffic about upcoming work zones indicate they are more effective than traditional work zone warning signs (18, 19). A study by Zech and Mohan (2008) measured the effect of three commonly used CMS in reducing vehicle speeds in work zones. The study recorded the speed of 180,000 vehicles on Interstate 90 and found the “WORK ZONE/ MAX SPEED 45 MPH/ BE PREPARED TO STOP” message was effective in reducing the vehicle speeds between 3.3 and 6.7 mph, concluding a properly selected CMS message can significantly reduce traffic speeds in work zones (20).

Li and Bai (2011) used a CMS at 250, 750, and 1,250 feet from a work zone displaying “WORK ZONE AHEAD SLOW DOWN,” and discovered that a CMS will be more effective in reducing vehicle speed if placed between 556 to 575 feet from the work zone. Alternative messages on CMS, such as “YOUR SPEED IS ## MPH” changing to “SLOW DOWN,” followed by “MIMIMUM FINE \$200,” had positive effects on persuading drivers to reduce their speed. The results indicate the percentage of drivers who were driving 5, 10, 15, 20, and 25 miles over the speed limit were reduced by 20, 20, 10, 3, and 0.3 percent, respectively (21).

Dynamic speed signs, which can be trailer mounted or mounted on a permanent locations such as a light pole, can use laser detectors to measure speed and then display that speed to the approaching vehicles. Studies have determined that the use of dynamic speed signs in work zones can reduce a vehicle's speed by as much as 5 mph (22, 23). Several other studies indicated speed reductions ranged between 1 and 8 mph upstream of the taper area had greater effectiveness within the work area, reducing speed from 3 to 6 mph (19, 24-27). The Petsi and McCoy's study results revealed a positive impact on the average speed reduction for the first week, but the sign effectiveness was reduced during the second week (28).

The presence of a speed photo enforcement van in a work zone that had the same function as the red light cameras, was successful in lowering vehicle speeds from 6.4 to 8.4 mph. In a different study, it was effective in reducing the speed by as much as 7.9 and 6.6 mph for cars and heavy vehicles, respectively (29).

The implementation of a speed trailer along the side of an urban road, which flashes the speed if the vehicle is traveling over the speed limit, was effective in reducing speeds by up to 2 mph (29).

The vast majority of the past research looked at the effectiveness of a single safety feature in a work zone. Hildebrand and Mason (2014) evaluated the effectiveness of safety measures in three different rural work zones with a semi-controlled environment in Canada. Speed data were collected at three spots, including 500 meter upstream, 75 meter upstream, and immediately adjacent to an activity area to approximate the speed profile of approaching vehicles. The safety measures identified and tested were Floating Speed Zones (FSZ), a Traffic Control Person (TCP), Narrow Lanes, a Radar Speed Display Board (RSDB), a

Variable Message Sign (VMS), and a Fake Police Vehicle. These traffic control measures were singularly and collectively evaluated to identify the most effective measure(s) in slowing traffic through the identified work zones. The study concluded that a combination of a TCP and an FSZ had the greatest effect in speed reduction by 23 km/h. A Fake Police Vehicle and an FSZ as well as a combination of an RSDB and an FSZ both slowed traffic by an average of 19 km/h (34).

A number of research studies were conducted to evaluate speed management strategies and effectiveness in highway work zones. Many of the past studies were conducted in a controlled environment and have produced mixed results in identifying safety features' effectiveness. The majority of previous research collected vehicle speeds using roadside radar guns and road tubes at a limited number of locations, then approximated speed profiles based on a few observations. A series of countermeasures have been used to attract drivers' attention to comply with work zone conditions and reduce their speed. However, there is limited information about which safety features are the most effective. Past research indicated the effectiveness of the speed reduction measures can sometimes vary considerably for unknown reasons which can be mainly attributed to driver behaviors that have not been truly investigated. The NDS developed and collected by the SHRP 2 provides a unique opportunity to observe actual driver behaviors and understand how they react to a series of safety measures intended to get their attention in work zones. In addition, using speed time series traces from the NDS, enabled us to determine the speed of the vehicle at any specified location upstream of the safety features and subsequently calculate the change in mean speed in reaction to any individual safety features in work zones.

### 4.3 Data Descriptions

Data for this chapter were acquired mainly from the SHRP 2 NDS and the SHRP 2 RID. The NDS collected time series data utilizing the DAS and video data collected by four cameras (6). This study uses vehicle speed time series data attributed to work zones. As speeding has been identified as one of the major contributing factors to work zone crashes, it is very important to observe and understand how drivers react to multiple safety measures applied in work zones to get their attention and reduce their speed.

The data used in this study went through a quality assurance process. Since most of the data were collected from sensors in real world driving environments, missing data were observed as one of the main issues. In order to control and ensure data quality in the analysis, the percentage of missing data were summarized for each identified speed trace in a work zone. The trace with more than 25% of the missing network speed data were removed from the dataset. Speed traces with missing values were interpolated assuming a constant increase or decrease.

#### 4.3.1 Data Collection and Data Reduction

The major effort on the data collection part of this research was identifying work zone locations within SHRP 2 data. The RID contains 511 data for most states involved in NDS for the duration of this study (October 2010 to November 2013). The 511 data and collected variables were very different among the states. A major field in 511 data which contains information about the potential work zones was the traffic event description. This field was queried for potential work zones by using key words such as “road work”, “lane closure”, “construction”, “maintenance”, “cross over”, or “head-to-head”. There were about two

million records that needed to be searched for potential work zones. The RID did not have 511 data for the state of Indiana, so that state was not included in the analysis.

The 511 data also contain information on the beginning and end of traffic events. Based on that, the duration of events which were work zones in our case was calculated. The work zones with durations of less than three days were removed due to the low possibility of having sufficient number of NDS time series traces for the short term work zones. As a result, 9,290 potential work zones were identified. The identified work zones were overlaid on NDS trip density data and mapped to the corresponding roadway link ID in the RID. The identified locations for 9,290 potential work zones were sent to VTTI to acquire the number of NDS time series traces, unique drivers, and driver demographic data associated with the links of interest that occurred within the duration of the work zones.

VTTI provided a list of potential trips associated with the links of interest along with driver information on those trips. The data were examined and work zones with at least 15 potential trips were selected, resulting in 1,680 potential work zones. The next step was requesting time series data associated with identified potential work zones. The estimation of the physical extent of each potential work zone was needed to increase the likelihood that the actual work zone was included. For this purpose, the identified roadway links were mapped to RID and the corresponding links were extracted. The dynamic segmentation function in ArcMap was utilized to add links to the upstream and downstream of each identified work zones.

The next step on this extensive data reduction effort was to submit a list of identified link IDs to acquire a sample time series trace and corresponding forward video for each potential work zone. About 3,000 traces were received and the forward video was reviewed

to determine if a work zone was actually present. Data collected from forward videos are shown in Table 4.1.

**Table 4.1 Extracted work zone characteristics from forward videos**

Presence of work zone (yes or no)	Locations of channelization
Lane closure Right or left	Type of channelization
Number of lanes closed	Spatial locations of work zone start and end points
Shoulder closures Right, left, or both	Presence and locations of workers
Dynamic message sign	Presence and locations of equipment
Types and locations of barriers (e.g., barrels)	Lane shift
Work zone speed limit	Active work zone

A set of criteria used to identify an active work zone included lane closure, shoulder closure, worker present, and equipment present. In some locations, where barrels were present along the side of roadway, the work zone was considered inactive and thus excluded. At this stage two main criteria to request the final set of time series data was set and confirmed. The forward videos were used to identify the true beginning and end points of each work zone and confirm if the work zone was actually active. A set of 118 coded active work zones including various work zone configurations (such as lane closure and shoulder closure, etc.) and types (such as multi-lane divided and 4-lane divided, etc.) were requested. Approximately 4,800 time series traces with associated forward/rear video images were received from VTTI. At this stage traces with more than 25% of the missing network speed data were removed from the dataset. Speed traces with missing values were interpolated assuming a constant increase or decrease. All congested traces were removed and only traces

with free flow conditions were kept in the analysis. In addition, traces with very poor quality images were excluded due to the inability to identify vehicle's position or confirm if indeed it was an active work zone.

The final step of the process was to identify work zone features such as work zone signage, the start of the work zone, the start of the taper, and the start of the work area. The location of features identified in the forward video were spatially located by noting the nearest video time stamp. The time stamp was then matched with the one in the time series data utilizing interpolation. The location of features relative to the start of the taper, which was identified as zero, was calculated using the speed of the vehicle. In addition, the position of the vehicle relative to each safety feature was calculated using the same technique.

#### **4.3.2 Identification of Work Zones of Interest**

This study focuses on the analysis of vehicle speeds data in work zones. The objective of the study was to analyze various work zone characteristics such as left lane closed, right turn closed, and lane shift. It was also desired to analyze different type of safety features such as lane closed sign, DMS, DSFS, work zone speed limit signs and so on. A total of five work zones with different characteristics has been selected for the analysis in this study. The characteristics of the five selected work zones are shown in Table 4.2. There are three four-lane divided work zones with left lane closures, but they have different types of safety measures such as a DMS or DSFS. Work zone 1 include a DMS as a safety measure introduced right after the first work zone warning sign, while the DMS in the work zone number 2 is located after the merge sign.

**Table 4.2 List of work zone characteristics for sample work zones**

Work Zone	Work Zone Characteristics	Roadway Speed Limit (mph)	Work Zone Speed Limit (mph)	Number of speed profiles (Number of Unique Drivers)				
				Overall	Female	Male	Inside Lane	Outside Lane
1	Left lane closed 4-lane divided DMS after 1st WZ warning sign	65	↓ 55	62 (35)	33 (17)	29 (18)	36 (23)	26 (21)
2	Left lane closed 4-lane divided DMS after lane closed sign	65	↓ 55	42 (17)	29 (9)	13 (8)	26 (14)	16 (8)
3	Left lane closed 4-lane divided DSFS after 1st WZ warning sign	55	↓ 45	76 (30)	27 (15)	49 (15)	39 (20)	37 (19)
5	Right lane closed 4-lane divided DSFS after 1st WZ warning sign	55	↓ 45	68 (29)	24 (15)	44 (15)	53 (27)	15 (9)
9	Lane shift 4-lane divided	55	55	37 (20)	19 (9)	18 (11)	16 (12)	21 (10)

Work zone 3 contains a DSFS located at 2,200 feet upstream of the taper. Work zone number 4 has a right lane closure configuration on a 4-lane divided highway and contains DSFS as a safety measure to get drivers' attention to reduce their speed. Work zone 5 is a lane shift situation which does not include any ITS device as a safety measure.

The video of each trace was observed to locate the start and end of the work zone, the start of the taper, the start of the work area, and all individual safety measures. This was accomplished by spatially locating the features of interest in the video and matching the time stamp in the video with that of the time series data by interpolation. Then, the location of features relative to the start of the taper, which was identified as zero, was calculated using the speed of the vehicle. A list of coded features in work zones is shown in Table 4.3.



**Table 4.3 Work zone features extracted from forward videos**

<b>Coded Features in Work Zones</b>	
Work Zone 1st Warning Sign	Work Zone Speed Limit Sign
Work Zone Advisory Sign	Presence of Barrels
Work Zone 2nd Warning Sign	Presence of Jersey Concrete Barrier
Work Zone 3rd Warning Sign	Presence of Cones
Work Zone 4th Warning Sign	Merge Sign
DMS	Lane Closed Sign
DSFS	Start of the Taper
Flashing Arrow	Start of the Work Area

#### **4.4 Methodology**

Functional data analysis (FDA) deals with the analysis of the data that are in the form of functions. The speed time series data from SHRP 2 NDS were collected at a high frequency and are the source of data for this research. Although the collected data are function like data with high dimensions, they are in a discrete format that needed to be converted to a functional format. In this section an overview of the FDA process along with the mathematical properties supporting each step of the process is discussed. The actual example of each process is demonstrated to help the reader have a better understanding of the process.

##### **4.4.1 Applying Functional Data Analysis to Discrete Raw Data**

The speed time series data from SHRP 2 NDS comes as a discrete dataset, which contains  $y_1, \dots, y_n$  observations. The function  $f(t)$  is the representation of the continuous underlying process. The  $f(t_i)$  is the notation for the underlying process at time  $t_j$  and the symbol  $y_j$  representing a corresponding noisy observation, where  $j = 1, \dots, n$ . The continuous

function therefore contains  $n$  pairs of  $(y_j, t_i)$ . Therefore these data can be used to estimate characteristics of function  $f(t)$  at unobserved time points (4-6). The speed time series of a single trace with fitted curves to the discrete observations are shown in Figure 4.1. The plot represents a single speed time series raw data collected over work zone one and zoomed to a portion of the trace for a better illustration. There were 240 observations over 24 seconds, which are denoted by black points.

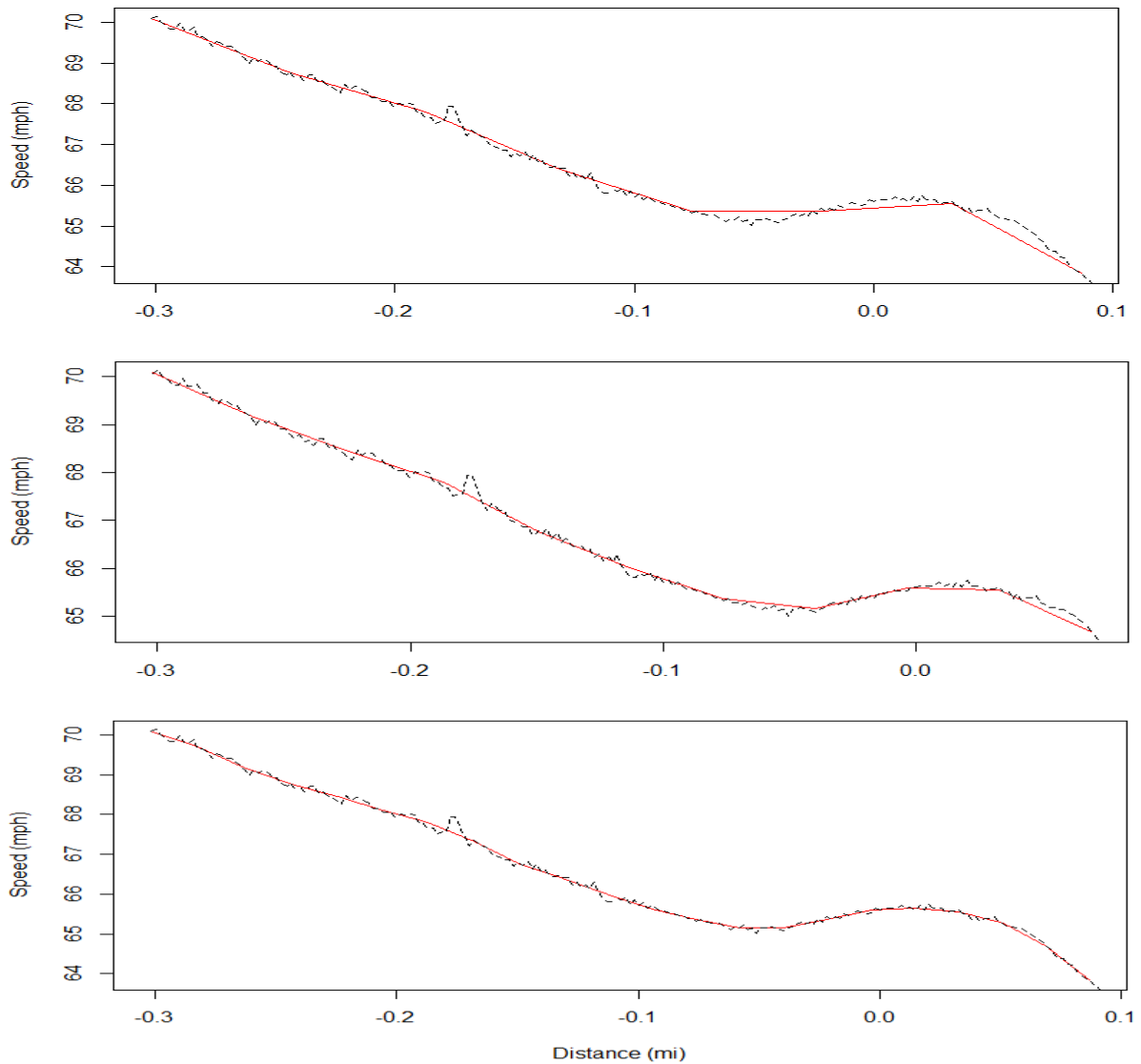

**Figure 4.1** Single speed time series trace of discrete raw data converted into a functional curve at 3, 2, and 1 second interval from top to bottom panel, respectively

The discrete observations were fitted with a functional object demonstrated as a red line in 3 examples. The conversion was done at different frequencies from lower (every 3 seconds) to higher (every 1 second) and from top to bottom plots of fitted functions in Figure 4.1. The more frequent conversion obviously is more comparable to observed data points but it takes an enormous run time to complete the conversion for large datasets. The discrete data was converted to functional data in every 2 seconds in this research.

The conversions of discrete data to functional data have already corrected some of the noises that comes from non-continuous observations of field data. Even with a high collected frequency, the data points are not continuous.

Now, discrete observations can be related to the underlying smooth process through the Equation 4.1.

$$y_i = f(t_i) + \varepsilon_i \quad (4.1)$$

Where  $(y_i, t_i)$  are observed raw data, each  $\varepsilon_i$  is uncorrelated error with mean of zero and variance of  $\sigma^2$ , and  $i = 1, \dots, n$ .

#### 4.4.2 Developing Smooth Curves by Basis Expansion

In the previous section the discrete raw observations were converted into functional entities by fitting a curve to the raw discrete data to estimate the underlying process. The next step in this process is representing the discrete data as a smooth function by using a basis expansion. The basis expansion is used to represent a function as a combination of elementary functional building blocks as shown in Equation 4.2.

$$f(t) = \sum_{k=1}^k C_k \phi_k(t) \quad (4.2)$$

Where  $K$  represent the number of  $\phi_k$  basis functions,  $C_k$  are the basis coefficients which determine the relative weight of each basis function in constructing the function  $f(t)$ .

The basis expansion advantage is to represent the functions of a potentially infinite-dimensional world within a finite dimensional framework. In ideal situation, basis functions may contain features that match the known functions being estimated. This helps to reach a reasonable estimation by using a relatively small number of  $k$  basis functions.

The basis function  $\phi_k$  can be expressed in many different types of basis function systems such as the power of  $x$  for polynomial functions, Fourier basis for periodic function, and spline basis for non-periodic functions. For the situation of non-periodic curves with complex functions the low order polynomial is unable to capture all the features. The B-spline functions are the most commonly used for such situations and will be used in this study.

#### 4.4.3 Smoothing Process by B-splines

The B-splines are basically polynomials joined end to end at knots, which are a set of interval boundaries. The knots are often chosen to divide the desired time domain into equally spaced intervals. The knots may also be chosen at any specified time point of interest. The polynomials are smoothly connected at the knots. The B-spline are categorized by their order which is one larger than the polynomials degree they are constructed from. The spline with an order of three is usually used to confirm that first and second derivatives are smoothly connected at the knots. The basis coefficients weights are selected to make sure the developed curve optimally fitted the data. The smoothness is controlled by the number of basis functions selected. The larger number of basis functions caused the curve to be fitted to the raw data points more accurately. Although the large number of basis functions create a

representative of the raw discrete data, it may cause over-smoothing issues. The scree plot was used to select the optimal number of basis functions needed to produce a smooth curve as illustrated in Figure 4.2.

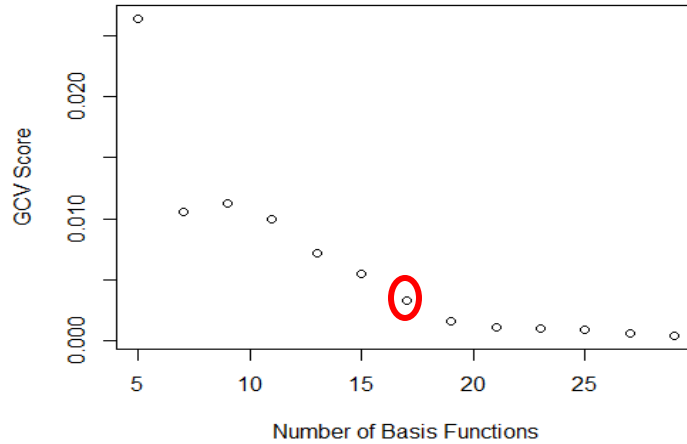

**Figure 4.2 Scree plot for selecting the optimal number of basis functions**

The scree plot result showed 17 as the optimal number of basis functions to construct a proper smooth curve for the data. The structure of splines basis functions is shown in Figure 4.3.

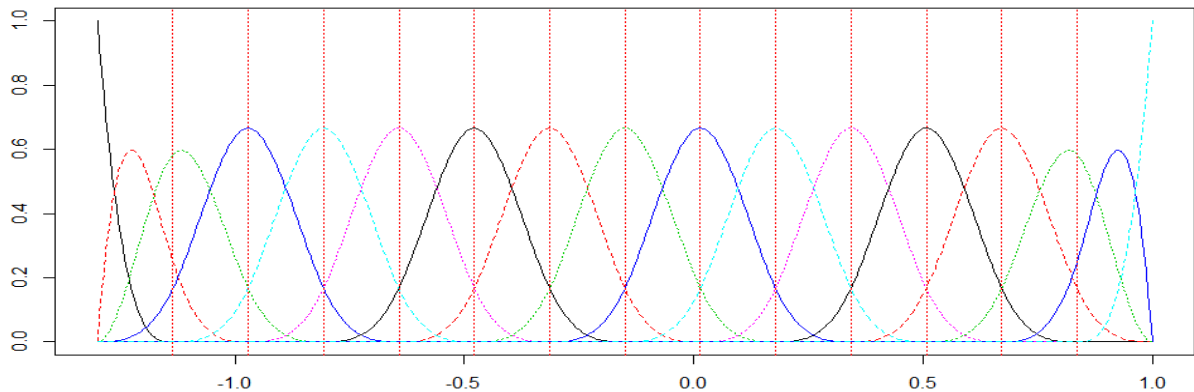

**Figure 4.3 The length of 2.3 mile work zone is illustrated by 17 spline basis functions and 13 interior knots with order four polynomials**

There are 17 spline functions fitted to a speed trace in work zone one over a 2.3 miles stretch of work zone from 1.3 miles upstream of the start of the taper (point zero) to one mile

after the taper point. There is a spline as a polynomial with a specified order over each interval. The rule is defined by Ramsay et al., 2015, as “*The total number of degrees of freedom in the fit equals the order of polynomials plus the number of interior breakpoint*”

(6). The smoothing leaves some noise that is not truly part of the process. The over-smoothing may discard some high frequency behavioral data that reveals important information desired to be observed and analyzed in the study.

#### **4.4.3.1 Spline Smoothing Penalties**

In the smoothing process, there is a trade-off between fitting the raw discrete data and creating a smooth curve. The normal practice of fitting data in any model is to minimize the sum of squared error between the observed value and the estimated function. The objective of fitting B-spline function is the minimization of the least square principle as follow:

$$\sum_{i=1}^n (y_i - f(t_i))^2 + \lambda J(f) \quad (4.3)$$

The sum of squared error (SSE) is described in the first part of Equation 4.3 and the term added to the SSE is a penalty term,  $J(f)$ , to control for curve smoothness with smoothing parameter  $\lambda$ , which is tuning the goodness of fit and the regularity of the function. The smoothness of the fitted curve which is shown by  $J(f)$  in the equation 4.3 is a measure of curvature of the smoothing function that can also be shown as  $\int \{D^2 f(t)\}^2$ , known as an integrated squared second derivative. Replacing  $J(f)$  in Equation 4.3 with the integrated squared second derivative will create the Penalized Sum of Squared Error (PENSSE) shown in Equation 4.4.

$$\text{PENSSE} = \sum_{i=1}^n (y_i - f(t_i))^2 + \lambda \int \{D^2 f(t)\}^2 \quad (4.4)$$

The smoothing parameter  $\lambda$  is greater than zero. As the value of  $\lambda$  increases, the larger penalty is applied and creates a smoother function. On the other hand, the smaller  $\lambda$  constructs a function with higher roughness which is closer to the raw data.

To overcome the problem of overfitting, a cross validation technique was needed to choose the optimal smoothing parameter. The idea is to set part of the data to one side and call it a validation sample and fit the model to the remaining data which is a training sample. Here the goodness of the fit of the model to data that were not used for model estimation is observed. Generalized Cross Validation (GCV) was used to calculate  $\lambda$  as follow (6):

$$GCV(\lambda) = \left( \frac{n}{n-df(\lambda)} \right) \left( \frac{SSE}{n-df(\lambda)} \right) \quad (4.5)$$

The mean squared error measure is discounted twice. The right part of Equation 4.5 is an unbiased estimate of error variance  $\sigma^2$ , and the left part represent two discounts. A sample of functional data for work zone one involved 62 speed traces for raw discrete data, converted functions, and smoothed spline functions in Figure 4.4 demonstrates the whole process.

The top panel presents the raw discrete time series data collected at 10 HZ frequency. The middle panel shows the converted discrete observations to functional curve utilizing Equation 4.1. The bottom panel reveals smooth curves by utilizing the smoothing techniques which included basis expansion, fitting optimal number of B-spline functions, and applying appropriate penalty to guard against overfitting.

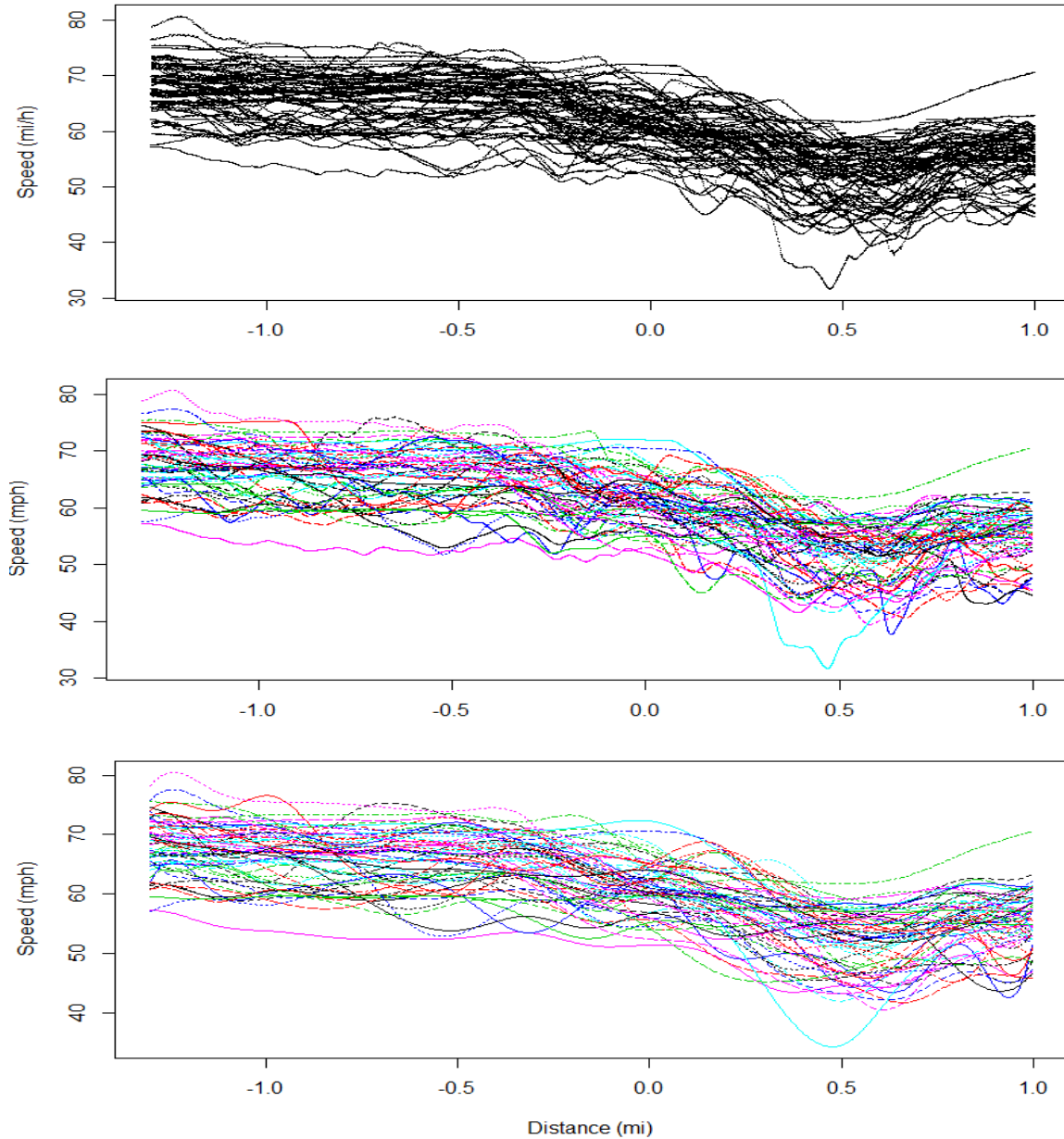

**Figure 4.4 Process of developing and smoothing functional data**

Raw speed traces (top panel), converted functional curve (middle panel) and smoothed fitted spline functions (bottom panel)

#### 4.4.4 Functional Data Summary Statistics

As for the classical statistical analysis, summary statistics can be similarly applied to the functional data. There are useful functional analysis techniques that can be utilized to do the statistical summary such as mean and variance for a group of converted functional data.



#### 4.4.4.1 Mean of Functional Data

One of the most useful statistical summaries of functional data is calculating the mean of functional data from a group of functional curves converted from the raw discrete observations. The functional data mean is a pointwise average for a group of functional observations. It provides an average curve that represents a repeated curves over the same locations at different time periods. The sample mean of functional data is expressed as follows:

$$\bar{x} = \frac{\sum f(t_i)}{n} \quad (4.6)$$

A plot of Figure 4.5 illustrates the calculated mean as a thick solid black line for a sample of 62 traces in work zones 1. Point zero shows the start of the taper and the other distances are relative to the taper location.

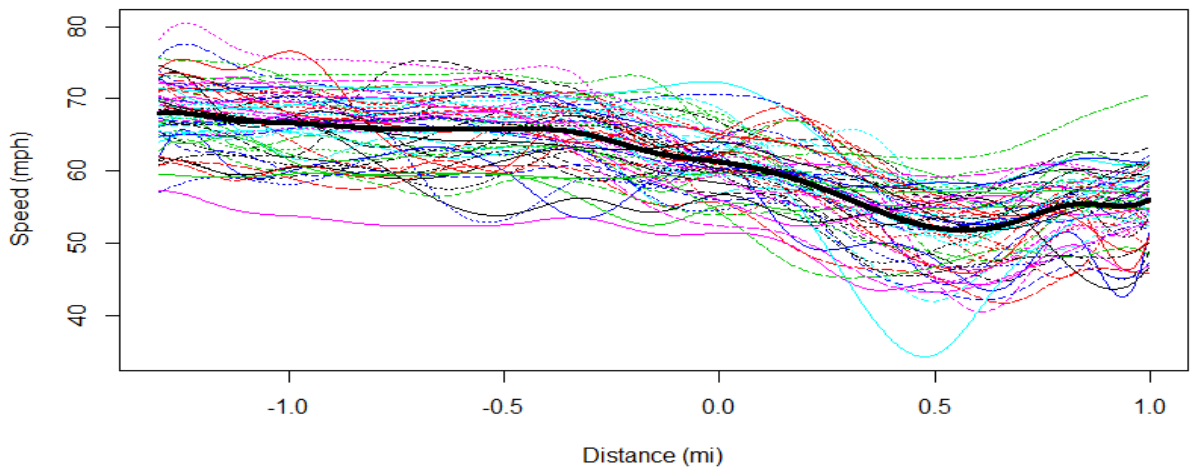

**Figure 4.5 Plot of smoothed speed profiles in work zone with calculated mean for 62 traces**

#### 4.4.4.2 Confidence Interval of Functional Data

The pointwise confidence interval can be derived from the variance-covariance matrix which is  $Var\{\hat{y}\} = \phi C \Sigma C^T \phi^T$  and can be written as Equation 4.7.

$$\hat{y}(t) \pm 1.96 \sqrt{\text{Var}\{\hat{y}(t)\}} \quad (4.7)$$

Figure 4.6 shows a sample plot of confidence interval as thick dotted blue lines for the mean speed profile based on Equation 4.7.

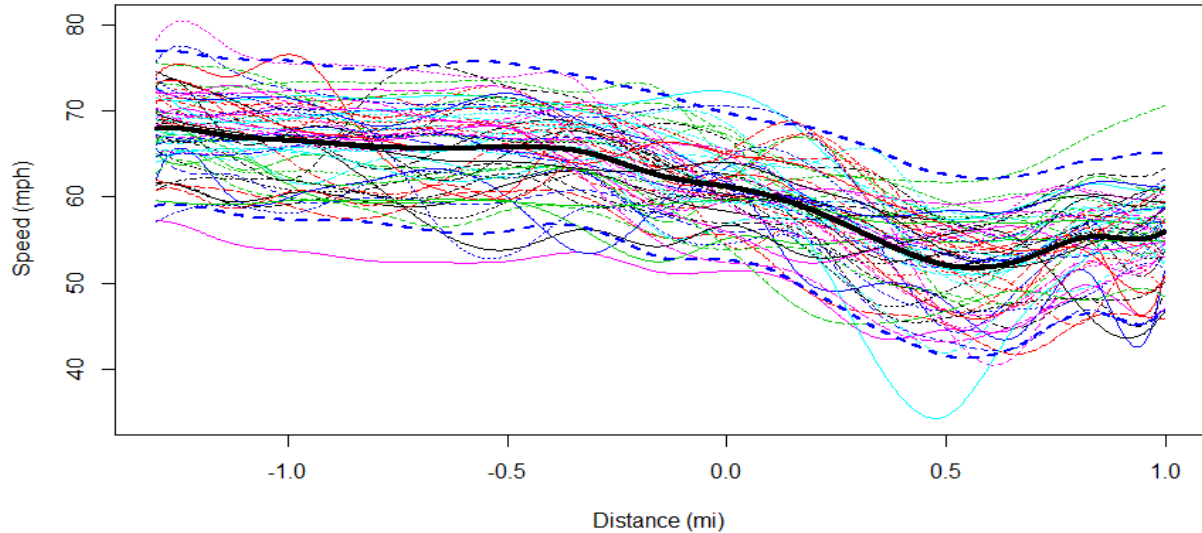

**Figure 4.6 Plot of smoothed speed profiles in work zone 1 with calculated mean and confidence interval**

#### 4.4.4.3 Derivatives of Functional Data

The rate of change in functional data is very useful to identifying the variations in the groups of functional data. The rate of change can be identified by using derivative method of functional data analysis. This method provides very useful information and explanations about the dynamics of variability. The first derivative of functional data  $f(t)$  can be expressed as:

$$Lf(t) = D^1 f(t) \quad (4.8)$$

The variable used in this study is speed and the first derivative of speed is acceleration, which provides useful information about drivers' behavior and reveals if they reacted to the safety measure and reduced their speed.

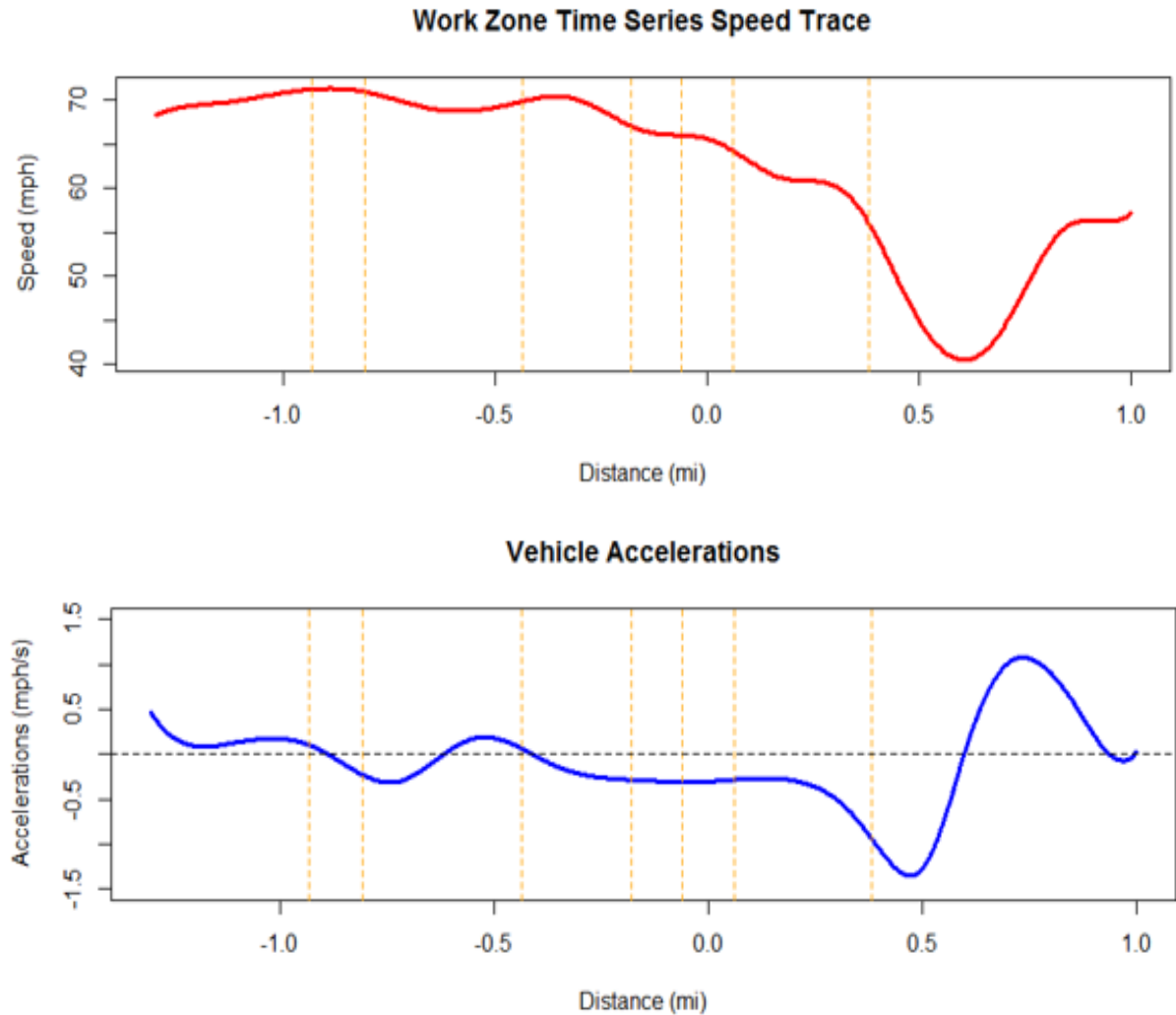

**Figure 4.7** A plot of a speed profile (top panel) along with its first derivative (bottom panel)

#### 4.4.4.4 Functional Boxplot for Functional Data

Functional boxplot is an informative exploratory tool for visualizing functional data. Visualizing data reveals informative features about functional data. The functional boxplot illustrates five important descriptive statistics, including the first and third quartile, the median, non-outlying minimum and maximum observations. Additionally, the boxplot can display any outlier function in the data. The boxplot was first introduced by Tukey, 1970, and evolved into an informative method in data visualization and interpretation (10).

The classical boxplot actually illustrates the middle 50% of data and this can be extended to functional data by the introduction of the central region concept by Liu et al., 1999. The band enclosed by  $\alpha$  proportion ( $0 < \alpha < 1$ ) of deepest curves of the sample used to estimate the 50% central region and expressed as:

$$C_{0.5} = \{(t, y(t)) : \min_{r=1, \dots, \lfloor \frac{n}{2} \rfloor} y_r(t) \leq y(t) \leq \max_{r=1, \dots, \lfloor \frac{n}{2} \rfloor} y_r(t)\} \quad (4.9)$$

Where  $\lfloor n/2 \rfloor$  is the smallest integer that is not less than  $n/2$  (35).

A sample data from work zone one was used to construct the functional boxplot which is represented in Figure 4.6. The 50% central region in magenta color is represented by a surrounding border defined as an envelope in the boxplot. Since the 50% central region is not affected by extreme values and outliers, it provides a less biased and solid range of data for interpretation and analysis of the behavior among a group of repeated time series data.

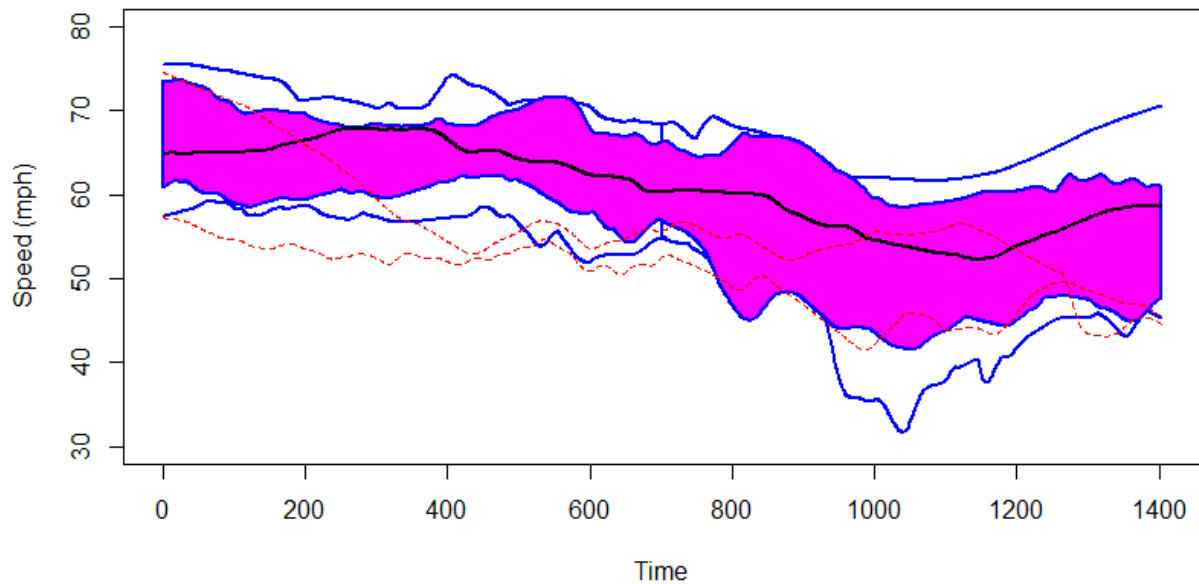

**Figure 4.8 Functional boxplot of speed profiles in work zone one**

The black curve in the box represents the median which is an important statistics to measure centrality. The blue lines which act as fences to the box are obtained by inflating the

50% central region envelope by 1.5 times the range of the 50% region. The outliers which were placed outside the constructed fences are shown by dashed red-lines.

The methodologies for a functional data analysis process and methods, along with graphical examples, were used to define the relatively complicated process of functional data analysis. The applications of all the tools discussed here are examined in the analysis of the results.

#### **4.4.5 Legibility Distance**

The legibility of a sign is determined by its font size, color, height, and reflectivity. Detecting and reading a sign involves a complex physical and mental process. This process is also affected by other roadway, traffic, and environmental factors. The legibility distance of a sign can be identified by a legibility index which represents the distance in feet that a sign may be read for every inch of a capital letter height. If the sign has the legibility index of 30, the sign is readable at a distance of 240 feet if the capital letter height is 8 inches (37).

In this study, the effectiveness of safety features is determined by measuring the change in a mean speed from a legible distance to the feature location. Some assumptions were made to select the legibility distance for different types of safety measures applied in the study's work zones. The types of traffic controls used in 5 work zones of this study include static work zone warning signs, DMS, DSFS, work zone speed limit signs, flashing arrow signs, and lane merge signs.

##### **4.4.5.1 Static Signs**

The assumption for astatic work zone warning sign is based on a 6 inch capital letter height and the legibility index of 30 which provides a legibility distance of 180 feet.

#### ***4.4.5.2 Dynamic Message Signs (DMS)***

The assumption made for DMS legibility is based on current MUTCD guidelines recommending a legibility distance of 650 feet based on the character height of 18 inches, however, due to another recommendation of MUTCD for the distance of 600 feet at night and 800 feet for normal daytime conditions, the legibility distance of 600 feet was selected for the purpose of this study (38).

#### ***4.4.5.3 Work Zone Speed Limit Signs and Dynamic Speed Feedback Signs (DSFS)***

The assumptions made for a speed limit sign and a DSFS are a 36 by 36 inch sign plaque with a 15 inch letter height. The legibility distance based on a legibility index of 30 is 450 feet. Although there might be situations with a larger letter size, the legibility distance for these types was selected as 450 feet for consistency.

#### ***4.4.5.4 Flashing Arrow Signs***

The distance for the flashing arrows was selected based on the DMS assumption to be 600 feet.

#### ***4.4.5.5 Merge Signs***

The assumptions for the merge signs are based on two studies by Paniati (1988) and Zwahlen et al. (39-40), providing legibility distances which are different from each other. To be on the safe side we assumed the shorter distance of the two studies which is 270 feet.

#### ***4.4.5.6 Other Safety Features***

There are occasions in the work zone when the safety feature does not include any of the specified types mentioned earlier, such as the start of the taper or the work area, so assumptions are based on visibility. The reaction distance in such cases was selected based

on the locations identified as the point where the majority of drivers started to react to the specified safety feature.

#### 4.5 Functional Data Analysis Results

The functional data analysis tools were utilized to study driver behavior in various work zone configurations with a unique set of safety treatments applied to each. In this study the methods of functional data analysis were utilized to interpret and analyze driver behavior when encountering safety features in various work zone configurations. The methods will be used to identify the effectiveness of various safety features in different setups applied in work zones.

There are 5 work zone in this study, 3 with left lane closures and different safety measure layouts, one with a right lane closure, and one with a lane shift configuration. Details of work zones characteristics are provided in Table 4.2.

In this study the location of the work zone Temporary Traffic Control Devices (TTCD) were confirmed according to the Manual of Uniform Traffic Control Devices (MUTCD) guidelines, providing guidance on the use and implementation of the TTCD. The implementation of the TTCD usually follows the agency guidelines for road safety, considering factors such as traffic conditions, traffic volume, site conditions, and cost effectiveness of the safety devices. The selection of the TTCD depends on the nature of the road work. There are many different applications of work zones which are demonstrated in Part 6 of MUTCD (40).

Figure 4.9 shows a typical application of a suggested type and placement of a TTCD in a work zone. There are four signs associated with the stationary lane closure in the schematic, including the first warning sign, second warning sign, a lane closed sign, and a

flashing arrow. The placement locations are identified and the dimensions are shown as A, B, and C.

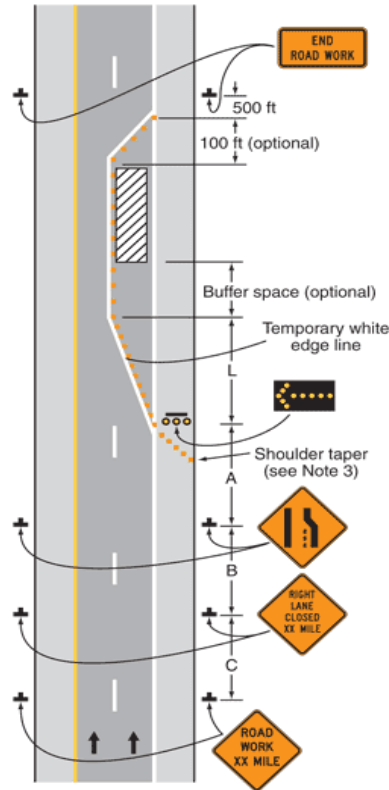

**Figure 4.9 Typical TTCDD application for a stationary lane closure arrangement on a divided highway (FHWA 2009)**

These dimensions can be calculated using the information in Table 4.4 which are defining the letter codes for the application of the TTCDD diagram. Dimension A is the distance from the point of restriction to the location of the first sign, which depends on the type and speed of the roadway as shown in Table 4.4. The first sign is the closest sign to the work area. The letters B and C are dimensions showing the distances between the first and second signs and between the second and third signs, respectively. The third sign is the furthest sign upstream of the work area. All of the 5 work zones in this study were selected in accordance with the suggested locations of the TTCDD with distance requirements.



**Table 4.4 Recommended advanced warning sign minimum spacing (FHWA 2009)**

Roadway Type	Distance Between Signs		
	A	B	C
Urban (low speed)	100 ft.	100 ft.	100 ft.
Urban (high speed)	350 ft.	350 ft.	350 ft.
Rural	500 ft.	500 ft.	500 ft.
Expressway / Freeway	1,000 ft.	1,500 ft.	2,640 ft.

The road types of all five work zones is expressway/freeway with a high speed limits. Therefore, the suggested distances of the signs was compared with the expressway/freeway category of Table 3.4. The distance of the closest sign to the point of a restriction was equal to or greater than 1,000 feet, and the distance of the furthest sign upstream of the transition point was also greater than 2,640 feet for similar conditions.

The results of the functional data analyses and major findings for the various work zone scenarios are provided in the following sections. The study intended to look at driver behaviors for overall, male, female, closed lane, and open lane drivers individually to see if there are identifiable differences among the comparable groups.

#### **4.5.1 Left Lane Closure with a DMS after Work Zone First Warning Sign**

The functional data analysis methods were used to identify the underlying process of driver behavior reacting to safety measures and summarized similarities and differences of 62 traces in work zone one from one-quarter mile upstream of the first work zone warning sign (at 0.93 mile upstream of taper), all the way through the work area. The y-axis represents the speed in mile per hour (mph) and the x-axis is the distance to the start of taper (point zero). The negative distance is upstream of taper point and positive distance is downstream of the taper. A series of safety measures applied in work zone one along with their locations are shown in Figure 4.10. The roadway speed limit is 65 mph and changes to 55 mph in the work

zone. There is only one speed time series trace. The vertical orange dashed-lines represent the locations of safety measures throughout the work zone. The first work zone warning sign was placed one mile upstream of the work area. This is slightly different than the calculated distance from the point zero (start of taper). The start of the taper was selected as the location where the transition or the point of restriction starts, as discussed in MUTCD typical diagram. Here the first point of restriction was where the barrels were introduced in the shoulder to gradually close the left lane.

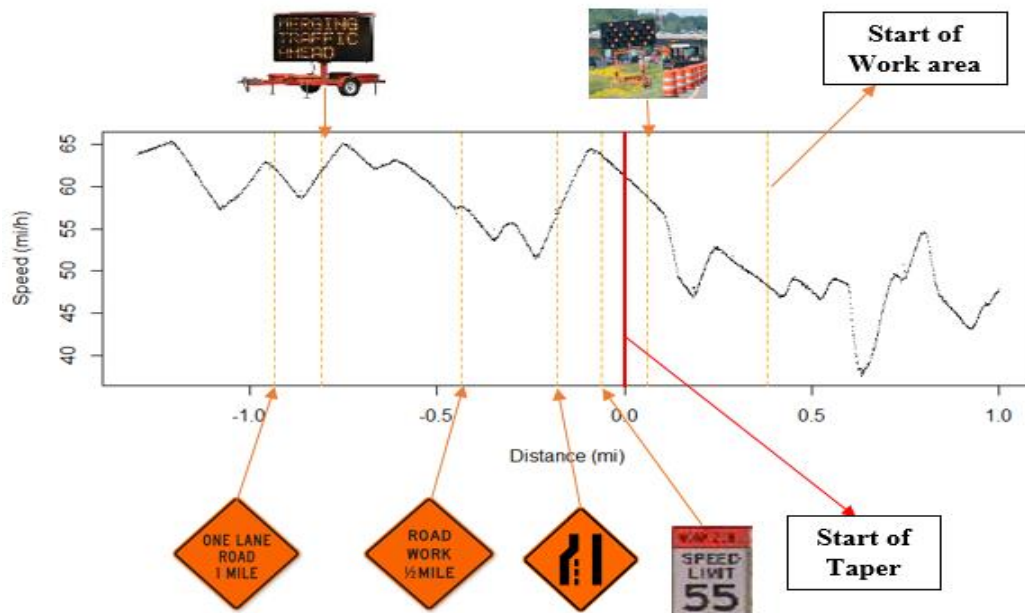

**Figure 4.10 Work zone one with left lane closure and utilized safety features types and locations**

A plot of the distribution of all traces differentiating male and female drivers is shown in Figure 4.11. The plot represents 62 traces which differentiate males and female traces. The male driver traces are in blue and the female driver traces are in orange. Speed time series traces reveal a mixed distribution for both genders throughout the work zone.

Another way to examine the distribution of the speed profiles in this work zone is by observing the open and closed lane traces which are represented in Figure 4.12.

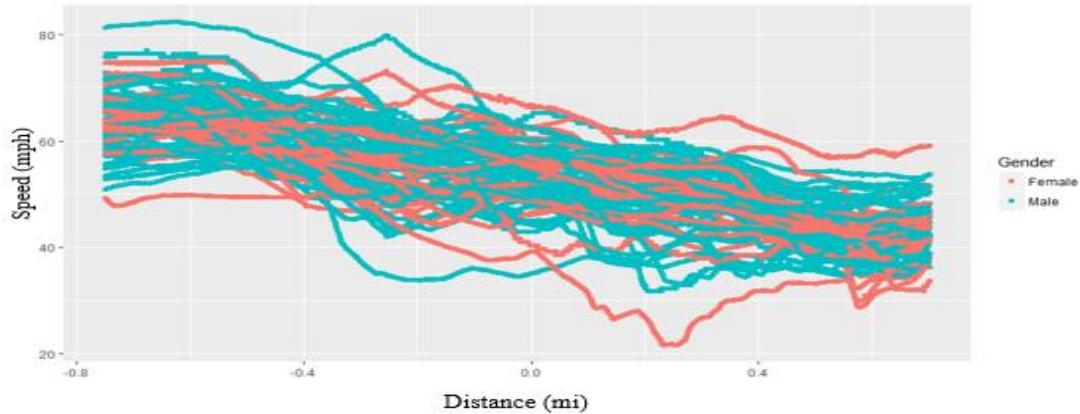

**Figure 4.11 Speed time series profiles showing male and female drivers in work zone one**

The closed and open lane drivers, speed traces are shown in orange and blue, respectively. The speed time series data reveals drivers in the closed lane mainly driving at a higher speed up to the start of the taper location, compared to open lane drivers.

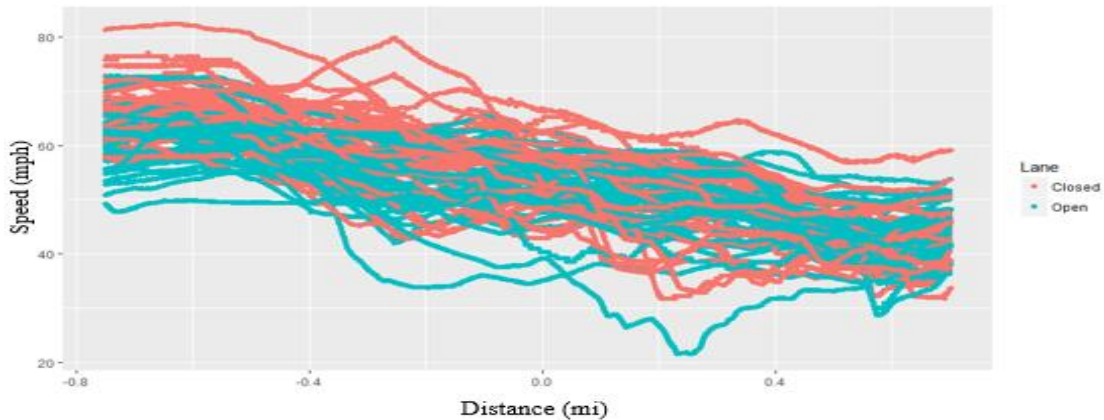

**Figure 4.12 Speed time series traces showing open and closed lane traces in work zone one**

The results of the functional data analyses for overall, male, female, closed lane, and open lane traces are discussed in the following sections for the five work zones with different characteristics and various safety features layouts. The observed discrete raw data were first converted to functional data and then the smoothed B-spline function was fitted to each speed trace as discussed in section 4.2.1.

#### ***4.5.1.1 Mean Speed and Confidence Interval of Functional Objects***

The average driver behavior for multiple speed profiles interacting with various safety measures in work zones was identified using the smoothed functional data. The mean speed is shown as a thick black curve along with blue dashed lines representing a 95% confidence interval in the left panel of Figures 4.13, 4.15, 4.17, 4.19, and 4.21 (a) through (e) for overall, male, female, open lane, and closed lane traces in work zones 1 through 5, respectively. The mean speed for all drivers shows a slight reaction to the presence of the first warning sign and the DMS. The reactions to these two signs were higher for female and open lane drivers, however, no reaction was observed for male and closed lane drivers at these two signs.

The first major reaction to the presence of a work zone started at about 1,800 feet upstream of the taper to the presence of the lane merge sign, speed limit sign, and the start of the taper for the overall model. The first reaction point for female and male drivers was at about 1,900 and 1,700 feet, respectively. The closed lane drivers' first major speed reduction occurred earlier than the other groups at about 2,100 feet, while open lane drivers reacted at about 1,750 feet upstream of the taper.

The biggest reaction was to the work area and the presence of equipment and workers. This occurred at about 950 feet upstream of the work area for the overall and male drivers, and about 900, 800, and 1,000 feet for female, closed lane, and open lane drivers, respectively.

The speed traces showed an overall high dispersion in this work zone, particularly in the vicinity of the work area. The width of the confidence interval for the overall model was 8.9 mph at the upstream of the work zone, increasing between the DMS and the second

warning sign (9.5 mph), narrowing again past the second warning sign (9 mph), increasing again closer to the taper point (9.5 mph), and increasing even further closer to the work area (9.8 mph).

The width of the confidence interval was higher for female and open lane drivers compared to male and closed lane drivers. This was more apparent at the upstream all the way to the point when they started to react to the presence of the lane closed sign and the taper area. The confidence interval upstream of the first warning sign was 9 and 7.5 mph for female and male drivers, respectively, however, they both increased at the work area to 11.4 and 8.9 mph for female and male drivers, respectively. The confidence interval for open and closed lane drivers upstream of the first sign was 8.6 and 7.5 mph and increased to 10.5 and 10.4 mph at the work area, respectively.

#### ***4.5.1.2 Functional Boxplots***

The functional boxplots is a very useful visualization tool to present the middle 50% of data limited by the first and third quartiles. It is based on the notion of depth which measures the centrality of an observation with respect to the remaining data. The functional boxplots for work zone 1 through 5 are shown in the right panel of Figures 4.13, 4.15, 4.17, 4.19, and 4.21 for the respective driving group to the left. Since the 50% central region is not affected by extreme values and outliers, it provides a less biased and solid range of data for interpretation and analysis of the behavior among a group of repeated time series observations. The plots show valuable information regarding driver behavior throughout the work zone interacting to a set of safety features.

The boxplot for the overall model shows the upstream speeds' tendency was toward the third quartile and above the median and continued to be the same up to the point of the

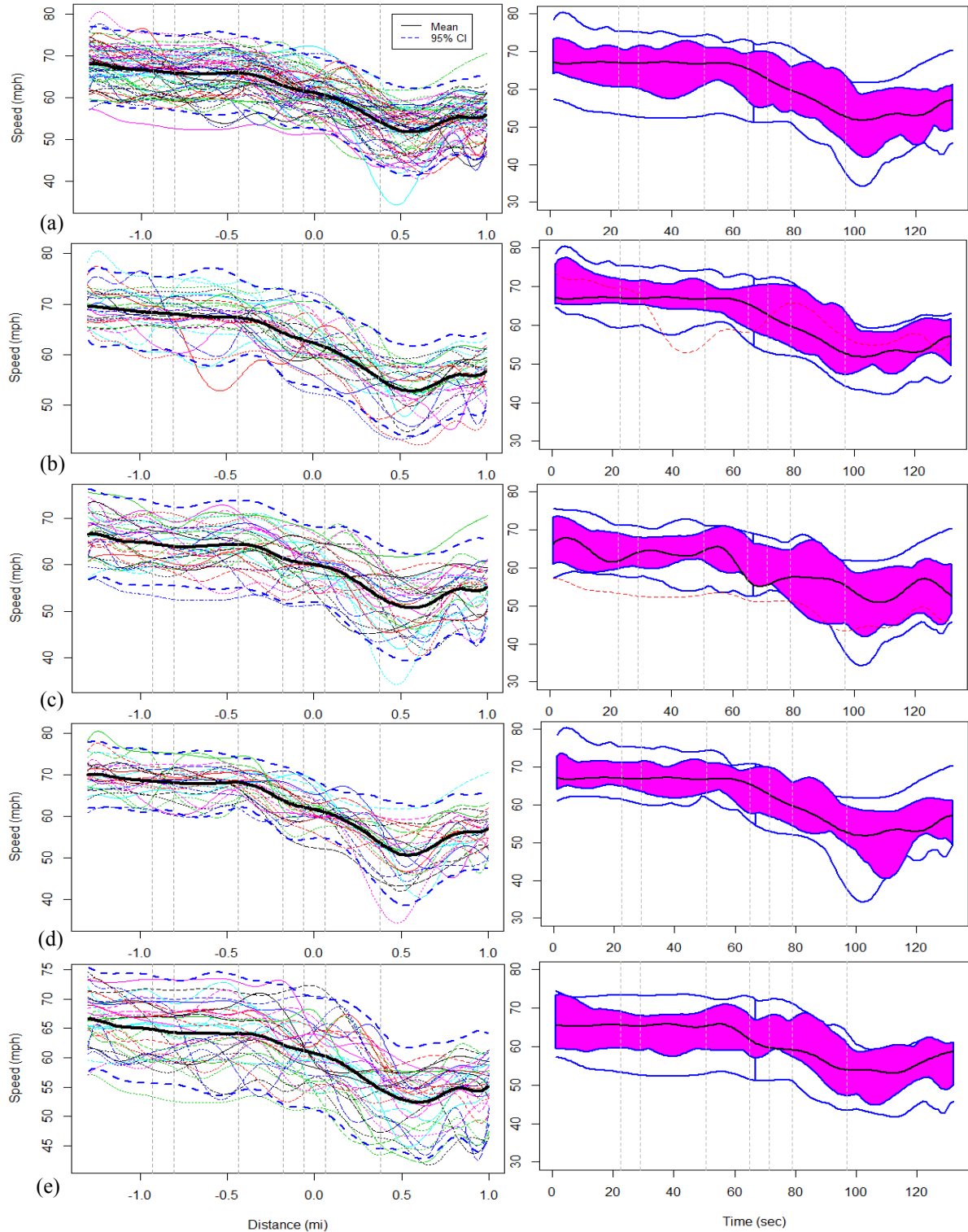

**Figure 4.13** Plots of mean speed, confidence interval, and functional boxplot in work zone one

Left panel. Plot of mean speed and confidence interval for speed time series traces for overall traces (a), male drivers (b), female drivers (c), closed lane traces (d), and open lane traces (e)

Right panel. Plots of functional boxplots for the corresponding categories to the left

first major reaction to the work zone at 1,850 feet upstream of the taper. However, there was a different trend for the first quartile limit. The trend was moving lower in reaction to the first two signs and then was moving higher from 0.6 mile upstream of the taper until the point of reaction to the lane closure and taper area. Then, the speeds were scattered equally above and below the median with a slight tendency toward the lower range for the remaining of the work zone.

The female drivers' speed traces revealed higher fluctuations compared to the male drivers. The speed for male drivers has a narrower 50% middle depth and was mainly below the median and toward the first quartile limit. The female drivers speed present a wider 50% depth, particularly after their first major reaction to the presence of the work zone and in the vicinity of the work area. The closed lane drivers' speed profiles also present a narrower 50% middle depth compared to open lane drivers from the upstream all the way to the point of their first major reaction. The models for both male and female drivers show the existence of one outlier in the speed profiles of these groups.

#### ***4.5.1.3 Vehicle Acceleration Profiles***

The rate of change can be used to see how drivers reacted and reduced their speed to different safety features utilized in work zones to slow the traffic down. The deceleration rate can be used to see if male and female drivers reacted differently to the presence of work zones with various configurations. The deceleration rate for overall, male, female, open lane, and closed lane drivers in five work zones with different characteristics and various safety features were calculated using first derivative of speed. The rates of change for drivers reacted to the safety features in work zone one are shown in Figure 4.14.

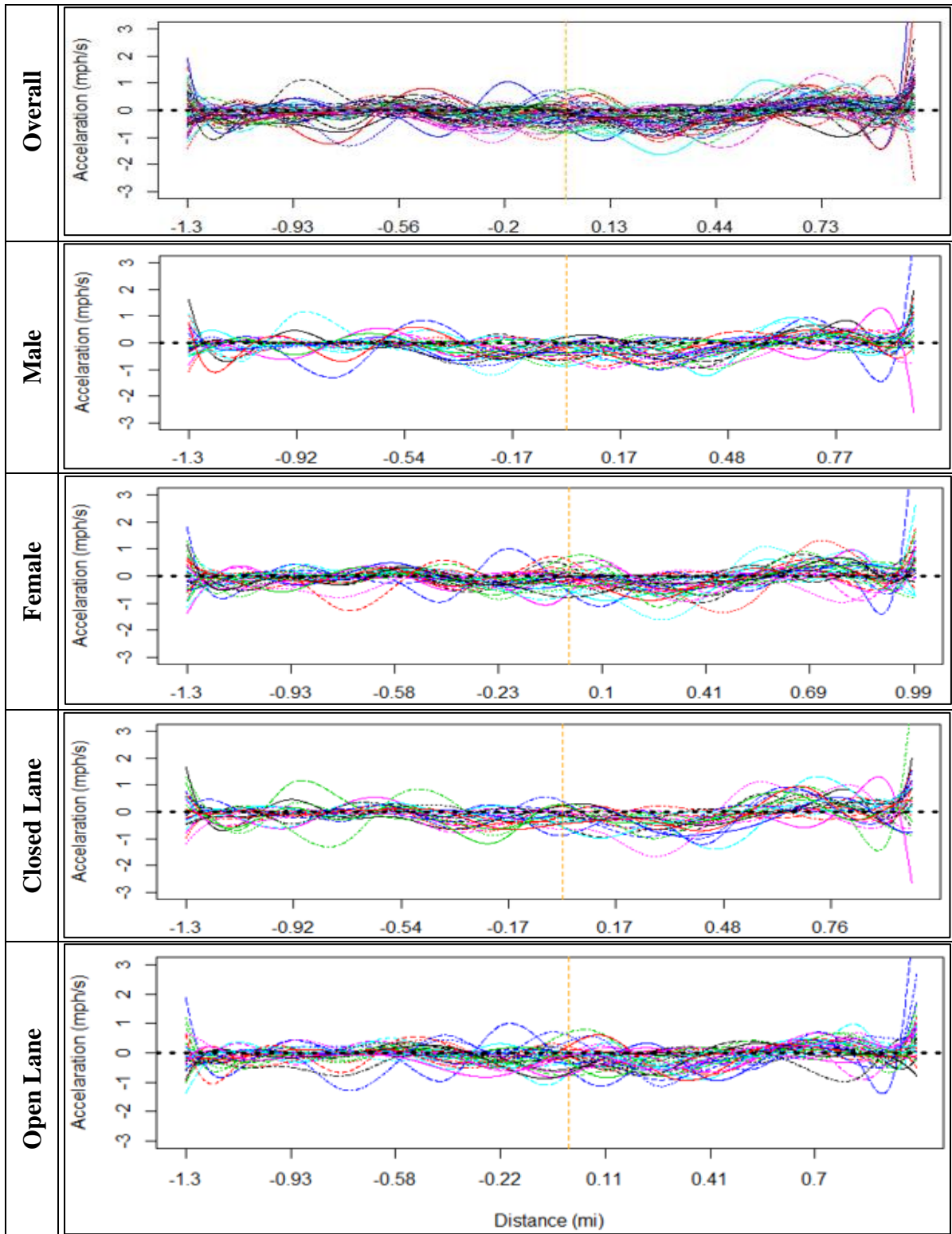

**Figure 4.14 Vehicle acceleration in work zone one with left lane closure and a DMS after the first warning sign**



The first derivative for vehicle speed was calculated using derivatives of functional data methods discussed earlier. The y-axis shows the acceleration which is miles per hour per second. The rate was calculated for each observation (every 0.1 second) and averaged for each second. The acceleration then was plotted against the distance from the start of the taper which is shown as an orange dashed line. The negative values indicate upstream and positive values are for the downstream of the taper.









There was a minimal deceleration for overall traces in reaction to the first two safety features at 0.93 and 0.8 miles upstream of the taper. The majority of vehicles started to decelerate from the location of second warning sign at about 0.4 mile upstream of the taper and reached the maximum deceleration at the work area. The deceleration turned into a slight acceleration in between the first and second warning sign, and also when vehicle moved to the other direction of the roadway for a head-to-head traffic. There were few drivers who demonstrated different deceleration behaviors which can be seen as outliers on the plots.

The deceleration rate was however different between comparable categories. The male and open lane drivers had a lower reaction to the first three signs and their deceleration rate was lower than the female and open lane drivers in reaction to the merge sign and the taper area safety features. There were couple of outliers in each category.

#### ***4.5.1.4 Effectiveness of Safety Measures***

Drivers reacted to the presence of a series of safety features as they approached and travelled through the work zone one. Changes in the mean and the associated variations for speed profiles are shown in Table 4.5. The change in mean speed was calculated from a legible distance upstream of each feature. The legibility distances were selected according to the type and the recommended distance for the desired feature discussed in the methodology.

**Table 4.5 Change in mean speed and standard deviation reacting to work zone one safety features**

Time series speed traces	Functional data summary statistics	1/4 mile upstream of first warning sign	180 ft upstream of WZ 1st warning sign	Change in mean speed at WZ 1st warning sign	600 ft upstream of DMS	Change in mean speed at DMS	180 ft upstream of WZ 2nd warning sign	Change in mean speed at WZ 2nd warning sign	First significant reaction point upstream of taper (ft)	270 ft upstream of merge sign	Change in mean speed at merge sign	450 ft upstream of WZ speed limit sign	Change in mean speed at WZ speed limit sign	520 ft upstream of taper	Change in mean speed at the start of taper	600 ft upstream of flashing arrow sign	Change in mean speed flashing arrow sign	800 ft upstream of work area	Change in mean speed at the start of work area
Safety Measure																			
Overall 62 Traces	Mean	67.46	66.46	-0.09**	66.29	-0.44*	65.77	-0.01	1,850	63.76	-0.89***	62.4	-0.8***	61.9	-0.73***	61.6	-1.01***	57.71	-3.52***
	SD	4.51	4.69	-0.08	4.58	-0.05	4.84	-0.17		4.62	0.2	4.86	-0.32	4.71	-0.34	4.54	-0.25	4.96	0.33
	Up. CI	76.3	75.66	-0.28	75.28	-0.56	75.27	-0.37		72.83	-0.52	71.93	-1.43	71.13	-1.39	70.5	-1.5	67.44	-2.89
	Lo. CI	58.6	57.26	0.03	57.31	-0.34	56.27	0.34		54.7	-1.28	52.88	-0.18	52.67	-0.07	52.7	-0.52	47.99	-4.17
Male Drivers 29 Traces	Mean	69.13	68.36	-0.06*	68.27	-0.27	67.79	-0.06	1,750	65.58	-0.91***	64.14	-1.17***	63.45	-1.22***	62.97	-1.53***	58.55	-3.31***
	SD	3.8	3.94	-0.13	3.76	0.01	3.6	-0.28		3.63	0.55	4.44	0.09	4.57	-0.19	4.53	-0.39	4.17	0.37
	Up. CI	76.58	76.08	-0.32	75.64	-0.25	74.85	-0.63		72.69	0.16	72.84	-1	72.4	-1.58	71.84	-2.29	66.74	-2.59
	Lo. CI	61.68	60.64	0.18	60.9	-0.28	60.73	0.49		58.46	-1.98	55.44	-1.35	54.5	-0.86	54.09	-0.76	50.37	-4.04
Female Drivers 33 Traces	Mean	65.98	64.78	-0.16**	64.56	-0.61***	63.99	0.04	1,950	62.17	-0.89***	60.87	-0.47	60.52	-0.28	60.4	-0.56	56.98	-3.72***
	SD	4.62	4.72	-0.1	4.59	-0.26	5.14	-0.11		4.86	-0.01	4.76	-0.49	4.46	-0.25	4.27	0.08	5.52	0.26
	Up. CI	75.05	74.04	-0.36	73.55	-1.11	74.07	-0.19		71.7	-0.92	70.2	-1.43	69.28	0.78	68.76	-0.4	67.8	-3.2
	Lo. CI	56.92	55.54	0.02	55.56	-0.1	53.92	0.25		52.64	-0.86	51.54	0.49	51.77	0.21	52.04	-0.71	46.16	-4.24
Closed lane 26 Traces	Mean	69.62	68.35	-0.13*	68.19	-0.33	67.95	-0.06	2,100	65.17	-1.07***	63.58	-0.83**	63.05	-0.74	62.75	-1.12**	58.45	-4.12***
	SD	3.83	3.85	-0.18	3.61	-0.03	3.33	-0.17		3.54	0.33	4	-0.43	3.85	-0.76	3.57	-0.86	3.58	1.73
	Up. CI	77.12	75.9	-0.48	75.26	-0.39	74.48	-0.4		72.11	-0.42	71.42	-1.67	70.6	-2.24	69.75	-2.82	65.48	-0.74
	Lo. CI	62.12	60.8	0.23	61.12	-0.27	61.43	0.26		58.24	-1.71	55.75	0.01	55.49	0.77	55.76	0.57	51.42	-7.49
Open lane 36 Traces	Mean	65.9	65.09	-0.12**	64.93	-0.54***	64.2	0.02	1,750	62.75	-0.78***	61.55	-0.78**	61.07	-0.72*	60.77	-0.93**	57.18	-3.1***
	SD	4.36	4.82	-0.03	4.77	-0.14	5.19	-0.19		5.07	0.2	5.29	-0.28	5.13	-0.15	5.01	0.04	5.74	-0.39
	Up. CI	74.45	74.54	-0.19	74.27	-0.81	74.36	-0.34		72.69	-0.39	71.91	-1.31	71.12	-1	70.6	-0.87	68.44	-3.87
	Lo. CI	57.34	55.65	-0.06	55.58	-0.26	54.03	0.39		52.8	-1.16	51.19	-0.25	51	-0.42	50.94	-1	45.93	-2.35
Significance codes: 0.01%*** 0.05%** 0.1%*																			
SD = Standard Deviation, Up. CI = Upper Confidence Interval, Lo. CI = Lower Confidence Interval																			

One sample t-test was conducted to test the null hypothesis stating the mean speed at the upstream of the sign is equal to that at the sign location, in other words the change in mean speed from upstream of the sign to the location of the sign is equal to zero at 95% confidence level. The normal quantile plots, along with Shapiro Wilk test, were conducted to validate the normality of data distributions to fulfill the assumptions of one sample t-test. It should be noted that the large sample sizes used in all work zone ensure accurate p values in case of the violation of normality.

As model results revealed, there was a slight reaction from 180 feet upstream to the first warning sign, which was effective for the overall, female and open lane drivers at 5% significance level. The mean speed was significantly dropped from 600 feet upstream to the DMS for both female and open lane drivers at 1% level. The first major reaction occurred at upstream of the lane merge sign and about 1,850 feet upstream of the taper point. The reaction started earlier for female and closed lane drivers at 1,950 and 2,100 feet upstream of the taper, respectively.

Lane merge sign, work zone speed limit, start of the taper, flashing arrow, and the work area all had significant influence on the overall and male drivers to slow down at 99% confidence level. The female drivers had a significant reaction to the lane merge sign from 270 feet upstream of that at 1% significance level. Similarly, they reacted significantly to the work area from 800 feet prior to that at 1% significance level. However, a work zone speed limit sign, the start of the taper, and the flashing arrow didn't have a significant influence on female drivers. Closed lane drivers reacted to the lane merge sign, the work zone speed limit, the flashing arrow, and the work area at 5% significance level or higher. Open lane drivers,

on the other hand, reacted to all safety measures but the second warning sign and the taper point at 5% level or higher.

The standard deviation upstream of the first warning sign was about 20% higher for female drivers compared to their male counterparts. It was also higher for the open lane compared to closed lane drivers. The first three signs had no major effect on the changing of speed variations. The reaction at the lane merge sign caused an increase of up to 14% for male, 9% for closed lane, and 4% for open lane drivers. The speed limit sign, the start of the taper, and the flashing arrow had a positive impact in reducing the variations for all groups, with the exceptions of the speed limit sign for male drivers and the flashing arrow for open lane drivers. The work area, on the other hand, increased the speed variations for all groups, with the exception of open lane drivers who showed lower variations in the work area. The standard deviation for female drivers at work area was about 24% higher, 5.78 compared to 4.54 mph for male drivers.

In short, most of the safety features in this work zone significantly influenced drivers' speed behavior after the work zone's second warning sign. The reactions to the first three measures were somehow mixed. Female and open lane drivers had significant reactions to the presence of the first warning sign and the DMS, however, male and closed lane drivers had no significant reactions to the first three signs. The female drivers' reaction to the presence of the DMS was 35% higher than male drivers, and open lane drivers had over 50% higher reaction to the DMS compared to closed lane drivers. There were no reactions to the second warning sign. The first three signs had no impact on speed variations, however the merge sign caused an increase in speed variability for the vast majority of drivers. The next three safety measures helped to reduce the variations before increasing in the work area.

#### **4.5.2 Left Lane Closure with a DMS after Lane Merge Sign**

Various tools of functional data analysis were used to identify the underlying process of driver interaction with safety features and summarized similarities and differences of 42 traces in work zone two from 500 feet upstream of the first work zone's warning sign (at 0.35 mile upstream of taper) all the way to the work area. The proportion of female drivers in this work zone is more than two times higher than male drivers. The work zone speed limit was 55 mph, 10 mph below the roadway speed limit. A series of safety measures applied in this work zone including a merge sign, a DMS, a work zone speed limit sign, a taper, and a flashing arrow at -0.35, -0.27, -0.19, and 0.03 miles from the start of the taper, respectively. A DMS was located after the lane merge sign in this work zone.

##### ***4.5.2.1 Mean Speed and Confidence Interval of Functional Objects***

The average driver behavior for multiple speed profiles reacting to a series of safety features in work zone two was identified using the smoothed functional data. The average mean speed upstream of the first sign was about 63 mph for the overall model. It was higher for male drivers and lower for female drivers compared to the overall model, which shows no reaction to the first sign, which was a lane merge sign. The first major reaction to the presence of the work zone occurred at about 250 feet upstream of the DMS. The mean speed was gradually reduced in reaction to the speed limit sign at about 1,000 feet upstream of the taper and further to the start of the taper and the flashing arrow sign. After a period of steady speed at the taper area, drivers reacted to the presence of equipment and workers at about 1,100 feet upstream of the work area.

Surprisingly, male drivers' first major reaction was to the presence of the first sign at about 250 feet upstream of the lane merge sign. The mean speed gradually reduced until

about 400 feet after the speed limit sign and then remained constant for about 1,000 feet. The next major reaction for male drivers was at about 100 feet prior to the start of taper which was continued to the work area. In contrast, female drivers first major reaction was at about 150 feet before the DMS sign and the speed reduction continued until about 100 feet upstream of the taper point, remaining constant for about 1,600 feet. This reaction involved a more rapid speed reduction compared to male drivers. The next reaction was a gradual speed reduction started at 1,000 feet prior to the work area. The overall model is closer to the female drivers' model as the majority of traces in this work zone belonged to that particular group.

The closed lane model shows the first reaction at 400 feet upstream of the DMS with a rapid speed reduction until 800 feet before the taper location. There was a more gradual decline from this point to about 500 feet upstream of the work area, remaining steady through the work area. The open lane model reveals the first major reaction was at about 150 feet upstream of the DMS, similar to that of the female drivers, with a gradual speed reduction all the way to the work area.

The speed variations for the overall model was 10.8 mph prior to the first sign, started to reduce in reaction to the DMS to about 10.2 mph, particularly for the upper confidence limit with a 2.2 mph reduction. The width of the confidence interval continued to become narrower all the way to the work area at about 7.4 mph.

The width of the confidence interval for female drivers was about 11.5 mph up to the speed limit sign where it started to become narrower at about 8.8 mph and remained steady for the rest of the travel in the work zone, however, it was 11 and 7.9 mph for male drivers at similar locations.

The confidence interval in the closed lane model was wider upstream, narrowed rapidly at the first warning sign until 300 feet after the speed limit sign, where it widened a little and remained the same for the rest of the work zone.

#### **4.5.2.2 Functional Boxplots**

The functional boxplot for the overall model shows the upstream speeds were almost equally spread at above and below the median. The tendency increased toward the upper range of third quartile after the first warning sign and put more weight on the second quartile closer to the lower limit in reaction to the DMS. The speeds show considerable fluctuations in reaction to the DMS and the speed limit sign. After the speed limit sign, speed tendency shifted toward the upper range of third quartile before reacting to the work area at about 800 feet prior to that. The shift was toward the lower quartile range from this point on. The 50% middle range has a relatively low depth up to the taper area, where the depth gets much closer to the extremes, particularly to the lower extreme.

The boxplots for male and female drivers revealed contradicting conditions. The female drivers' speeds show large fluctuations throughout the work zone compared to male drivers. The tendency was toward the upper range of the third quartile until the taper area, where it shifted toward the lower range for female drivers, however, the speeds put more weight on the third quartile for male drivers after the taper toward the work area. The 50% middle depth is also fluctuating for female drivers. It started to get narrower in reaction to the first 3 signs before gets wider and closer to lower extreme in traction to the taper area. However, the male drivers 50% middle data was deep and close to the lower extreme at the upstream of work zone until after reaction to the first 2 signs where it became narrower and remained constant throughout the work zone.

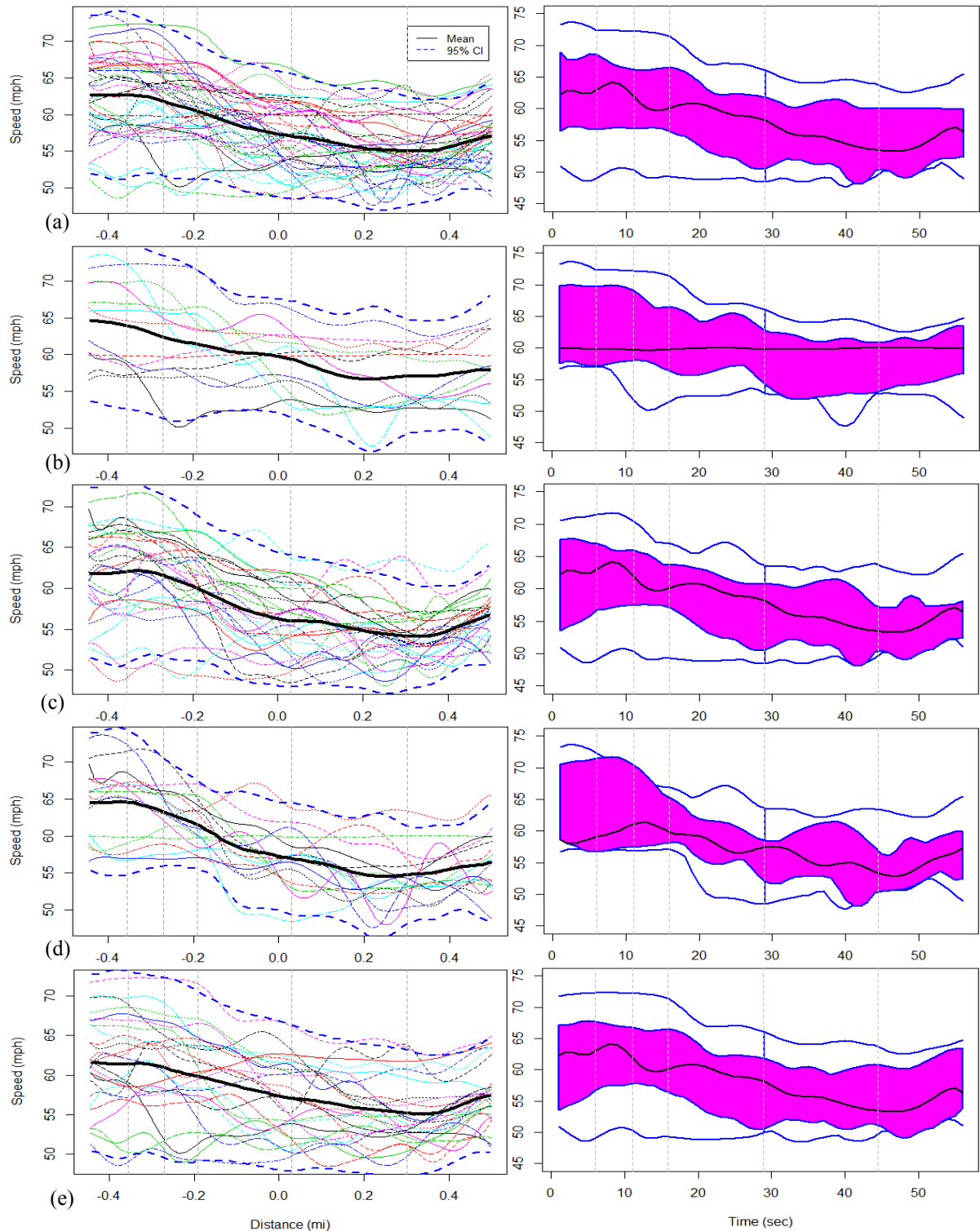

**Figure 4.15 Plots of mean speed, confidence interval, and functional boxplot in work zone two**

Left panel. Plot of mean speed and confidence interval for speed time series traces for overall traces (a), male drivers (b), female drivers (c), closed lane traces (d), and open lane traces (e)

Right panel. Plots of functional boxplots for the corresponding categories to the left



There was substantial variations in the 50% middle depth for closed lane drivers. It was almost similar to the non-outlier extremes at the upstream. It started to become narrower rapidly after the DMS and was getting wider again in reaction to the work area where the lower range was similar to the lower extreme throughout the work area. The open lane drivers' functional boxplot was quite similar to the overall boxplot.

#### ***4.5.2.3 Vehicle Acceleration Profiles***

The vehicle acceleration for each speed profile in work zone two was calculated from the functional data and were plotted in Figure 4.16. The speed reduction was observed in reaction to the DMS sign located after the merge sign at 0.31 miles upstream of the taper. The deceleration was then continued with lower intensity toward the taper and the work area. The maximum deceleration rate in reaction to the DMS sign which was located at 0.27 miles upstream of the taper location. The deceleration rate was then flattened for the remaining of the work area. There were few drivers with so many fluctuating deceleration reactions throughout the work zone. The sinusoidal waves were in between -2 to 2 mph per second.

The deceleration rate for female drivers was relatively higher than male drivers, specifically in reaction to the DMS. The closed lane drivers decelerated to the presence of the DMS while they had no reaction to the DMS when it was applied at 0.8 miles upstream of the taper in work zone one. The open lane drivers' deceleration profiles were almost straight after a small deceleration at the DMS, however, few outliers violated the flatness of the profiles. The most outstanding outliers were in the closed lane and female drivers groups.

#### ***4.5.2.4 Effectiveness of Safety Measures***

Changes in the mean and the associated variations for the speed profiles, as drivers approached and travelled through work zone two with an identified set of safety measures,

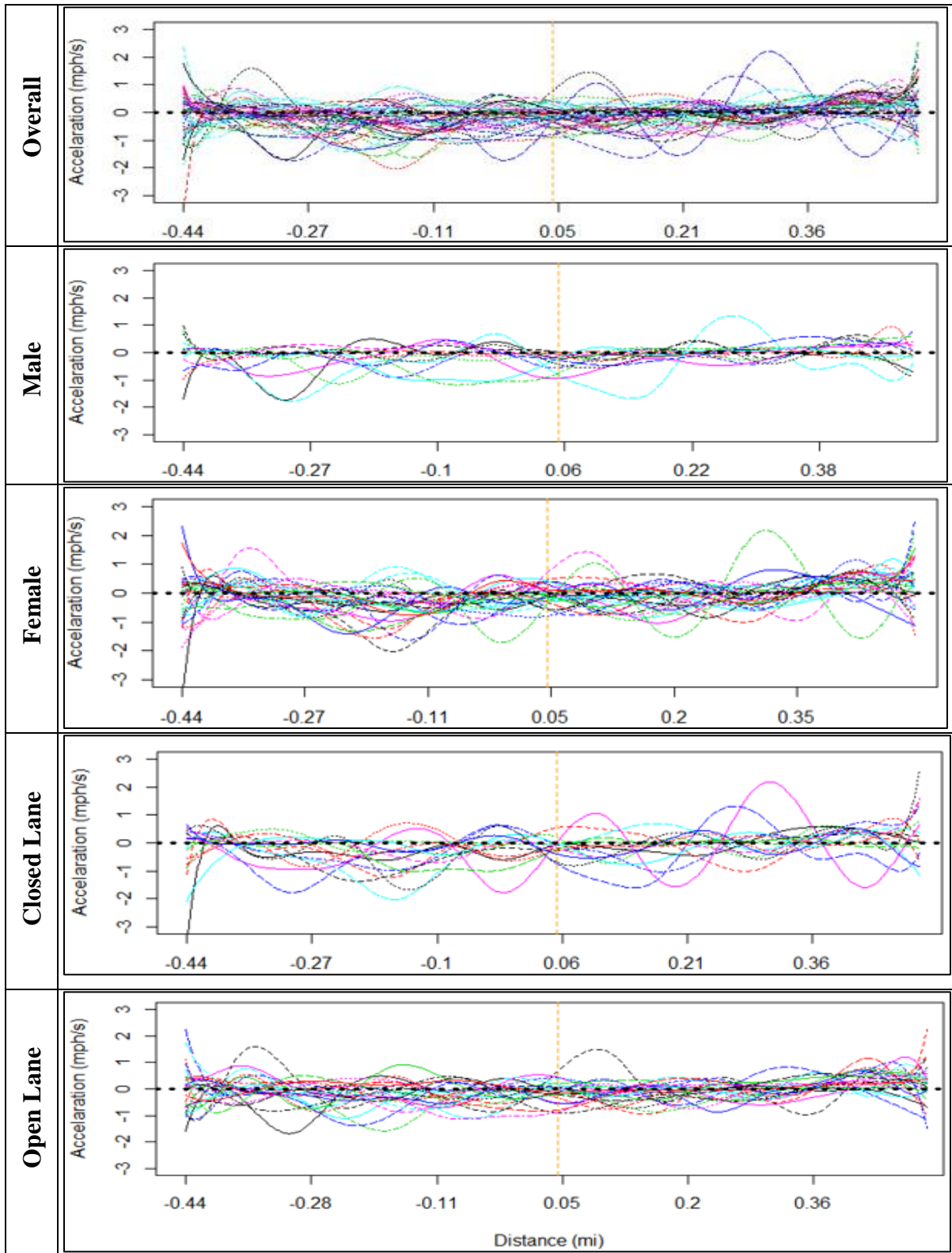

**Figure 4.16 Vehicle acceleration in work zone two with left lane closure and a DMS after the lane merge sign**







are shown in Table 4.6. The change in the mean speed was calculated from a legible distance upstream of each safety feature. The merge sign had a significant influence on male drivers, where overall, female, closed lane and open lane drivers had no reactions to it.

The first significant reaction to the presence of the work zone started at about 1,700 feet upstream of the taper in reaction to the DMS. Surprisingly, the reaction started earlier for male drivers and closed lane drivers at 1,950 and 1,750 feet upstream of the taper, respectively. The presence of the DMS had a significant influence on the overall, male, and closed lane drivers at a 5% level, while female and open lane drivers had no significant reactions

Significant reactions were observed at the speed limit sign, the start of the taper, the flashing arrow, and the work area for overall, female, and open lane drivers. Male drivers had a substantial reaction to the work area, but had limited reactions at the speed limit sign and the taper point. Closed lane drivers reacted significantly to the presence of the DMS, the speed limit sign, the start of the taper, and the work area, but their reaction to the flashing arrow was not significant.

Speed variations at the upstream of the merge sign, which happened to be the first sign in this work zone, was lower for closed lane drivers compared to other groups. Male drivers had slightly higher variations than female drivers. The merge sign caused a slight increase in speed variability for female drivers, with no major effect on other groups. After the first major reaction to the presence of the work zone upstream of the DMS, speed variability was decreased for overall, female, closed lane, and open lane drivers, however, the male drivers showed an increase in speed variation. All other safety features from the DMS to the work area successfully reduced the variation in speed for all groups, with the exception

**Table 4.6 Change in mean speed and standard deviation reacting to work zone two safety features**

Time series speed traces	Functional Data Summary Statistics	400 ft upstream of first sign	270 ft Upstream of lane closed sign	Change in mean speed at merge sign	First significant reaction point upstream of taper (ft)	600 ft Upstream of DMS	Change in mean speed at DMS	450 ft Upstream of WZ speed limit sign	Change in Mean Speed at WZ speed limit sign	520 ft Upstream of taper	Change in mean speed at the start of taper	600 ft Upstream of flashing arrow sign	Change in mean speed flashing arrow sign	1000 ft Upstream of work area	Change in mean speed at the start of work area
Safety Measure															
All 42 Traces	Mean	62.68	62.62	0	1,700	62.62	-0.82*	61.95	-1.46***	58.59	-1.25***	58.37	-1.37***	56.42	-1.38**
	SD	5.51	5.72	0.04		5.88	-0.71	5.19	-0.46	4.45	-0.07	4.47	-0.14	3.98	-0.2
	Up. CI	73.48	73.84	0.07		74.14	-2.19	72.13	-2.35	67.32	-1.37	67.13	-1.64	64.21	-1.75
	Lo. CI	51.88	51.41	-0.07		51.09	0.57	51.79	-0.58	49.85	-1.14	49.6	-1.09	48.62	-1
Male Drivers 13 Traces	Mean	64.6	64.47	-0.54***	1,950	64.26	-1.88**	62.54	-1.08*	60.32	-0.51	60.24	-0.96	57.78	-0.74***
	SD	5.64	5.75	0.04		5.81	-0.17	5.63	-0.47	4.01	-0.06	3.95	0.1	4.1	-0.1
	Up. CI	75.7	75.73	-0.45		75.64	-2.07	73.57	-1.98	68.18	-0.67	67.99	-0.73	65.83	-0.94
	Lo. CI	53.6	53.2	-0.62		52.88	-0.03	51.51	-0.17	52.47	-0.46	52.5	-1.17	49.74	-0.54
Female Drivers 29 Traces	Mean	61.83	61.8	0.24	1,650	61.88	-0.33	61.69	-1.63***	57.81	-1.56***	57.53	-1.55***	55.8	-1.66***
	SD	5.32	5.61	0.14		5.86	-0.82	5.06	-0.5	4.49	-0.32	4.5	-0.39	3.83	-0.45
	Up. CI	72.27	72.79	0.52		73.37	-1.95	71.61	-2.62	66.61	-2.18	66.35	-2.31	63.3	-2.53
	Lo. CI	51.38	50.8	-0.03		50.39	1.28	51.78	-0.65	49	-0.92	48.7	-0.79	48.3	-0.78
Closed lane 16 Traces	Mean	64.48	64.49	0.09	1,750	64.62	-1.41**	63.39	-1.86***	58.54	-1.29**	58.27	-1.4***	56.17	-1.43**
	SD	4.79	4.98	-0.01		5.09	-1.41	3.79	-0.73	3.8	-1.08	3.94	-0.09	3.56	-0.19
	Up. CI	73.86	74.27	0.04		74.6	-4.16	70.82	-3.3	66	-1.46	65.99	-1.57	63.16	-1.82
	Lo. CI	55.09	54.72	0.11		54.64	1.35	55.96	-0.42	51.08	-1.11	50.53	-1.21	49.18	-1.04
Open lane 26 Traces	Mean	61.58	61.47	-0.04	1,600	61.38	-0.44	61.07	-1.21***	58.62	-1.2***	58.43	-1.35***	56.57	-1.35**
	SD	5.72	5.93	0.04		6.08	-0.27	5.78	-0.3	4.88	-0.06	4.85	-0.18	4.27	-0.2
	Up. CI	72.79	73.09	0.05		73.31	-0.99	72.4	-1.79	68.19	-1.35	67.93	-1.7	64.94	-1.73
	Lo. CI	50.37	49.86	-0.13		49.46	0.09	49.75	-0.64	49.04	-1.07	48.93	-1.01	48.2	-0.96
Significance codes: 0.01%*** 0.05%** 0.1%*															
SD = Standard Deviation, Up. CI = Upper Confidence Interval, Lo. CI = Lower Confidence Interval															

of male drivers at the flashing arrow. The presence of the DMS, as the first significant feature at 1,400 feet upstream of the taper point was successful in getting drivers' attention to have a significant reaction to the work zone.

### **4.5.3 Left Lane Closure with a DSFS after Work Zone First Warning Sign**

Functional data analysis were used to identify the underlying process of driver behavior reacting to safety measures and summarized similarities and differences of 76 traces in work zone three from one-quarter mile upstream of the first work zone warning sign (at 0.5 mile upstream of the taper) all the way to the work area. The work zone speed limit was 45 mph, 10 mph below the roadway speed limit. A series of safety measures applied in this work zone included the first work zone warning sign with an attached advisory speed plate of 50 mph, a DSFS, second work zone warning sign with an attached advisory speed plate of 45 mph, a lane merge sign with an attached advisory speed plate of 45 mph, a taper, a flashing arrow, and channelization at -0.5, -0.4, -0.28, -0.18, 0.03, and 0.18 miles from the start of taper respectively. In this work zone a DSFS was located after the first work zone warning sign.

#### ***4.5.3.1 Mean Speed and Confidence Interval of Functional Objects***

The average mean speed at the upstream of the first sign was about 64 mph for the overall model. It was higher for closed lane drivers and lower for open lane drivers as expected. The upstream speed was almost similar for male and female drivers. The overall model shows the first major reaction occurred at about 600 feet upstream of the first work zone warning sign which was at 500 feet upstream of the DSFS. It was a relatively rapid speed reduction to the first two safety features and continued to about 200 feet before the lane merge sign. The mean speed remained constant until about 500 feet upstream of the

taper point where reacted to the taper and the flashing arrow sign. The next reaction was observed at about 600 feet prior to channelization when speed was rapidly reduced for about 800 feet and remained steady for the short distance before the next reaction occurred to the presence of the work area at 400 feet upstream of that.

Male drivers' mean speed revealed a late reaction to the presence of the work zone at about 200 feet compared to female drivers with early reaction at about 750 feet upstream of the first warning sign. The male drivers' reaction was a rapid speed reduction until the second warning sign, then remained constant until about 450 feet before the merge point when they reacted to the taper area and the flashing arrow. However, the female drivers' reaction extended longer up to the lane merge sign, then was constant until about 200 feet before the taper area and flashing arrow. There was a significant reaction to the channelization and the work area for both genders, where male drivers reacted a little earlier than female drivers ( about 100 ft) at about 1,500 feet upstream of the work area.

The closed lane model presents a late reaction compared to any other driver group at the first warning sign, which was located at 450 feet before the DSFS, while the open lane drivers' model showed the earliest reaction to the presence of work zone at 900 feet upstream of the first warning sign.

The width of the confidence interval for the overall model was about 10.5 mph upstream of the first warning sign, became wider in reaction to the first warning sign and the DSFS at about 13 mph, then decreasing in reaction to the work area at 10.8 mph. The confidence interval was slightly wider for male drivers compared to female drivers upstream of the first warning sign and after their reaction to the first two safety features. However, it became noticeably wider for female drivers after reacting to the merge sign at 13.9 mph

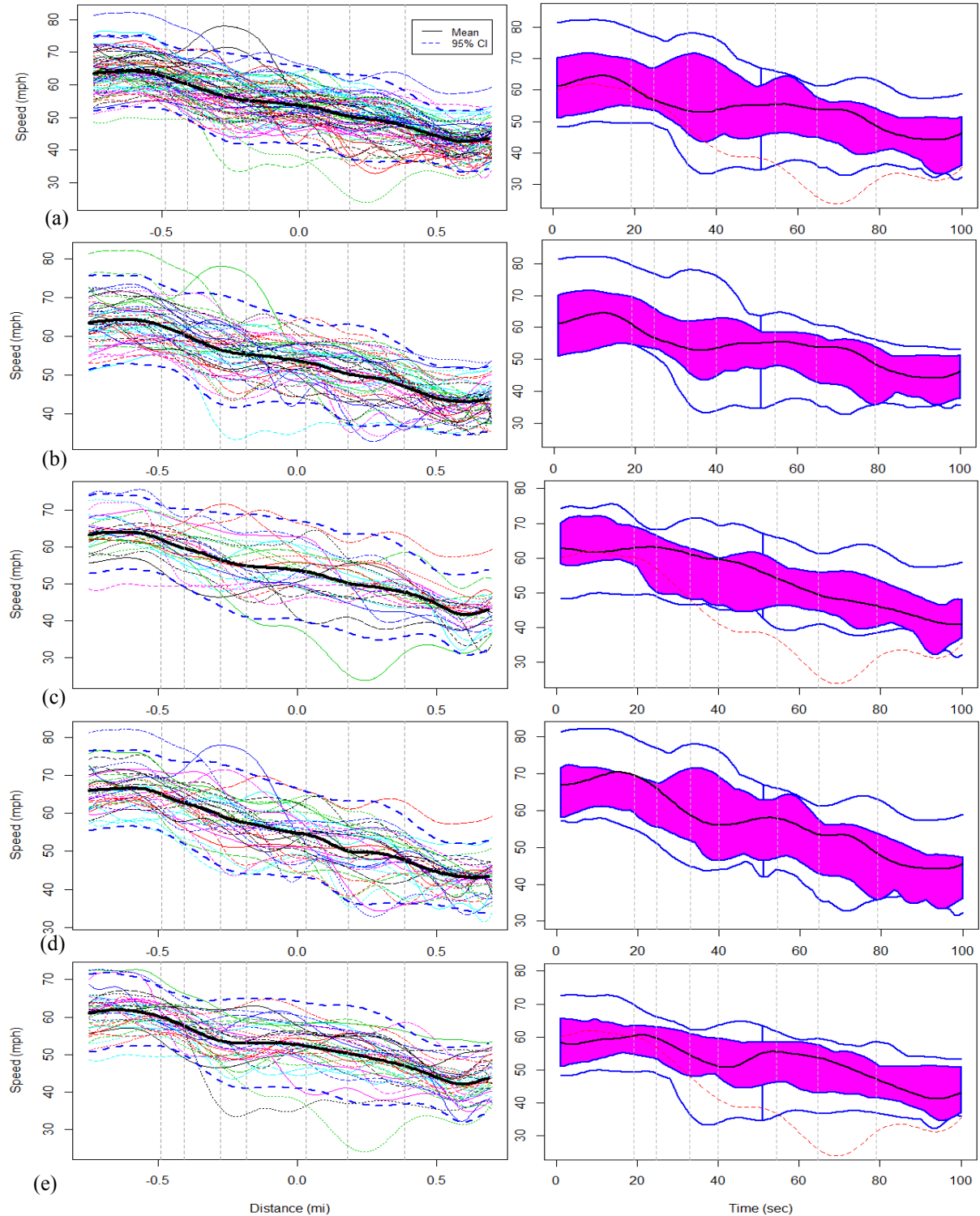

**Figure 4.17 Plots of mean speed, confidence interval, and functional boxplot in work zone three**

Left panel. Plot of mean speed and confidence interval for speed time series traces for overall traces (a), male drivers (b), female drivers (c), closed lane traces (d), and open lane traces (e)  
 Right panel. Plots of functional boxplots for the corresponding categories to the left

compared to 11.6 mph for female drivers and was 11.9 and 10.3 mph at the work area for female and male drivers, respectively. The confidence interval for closed lane drivers was about 3 mph wider than open lane drivers at both upstream of the first sign and at the work area.

#### ***4.5.3.2 Functional Boxplots***

The functional boxplot for the overall model shows the upstream speeds tendencies were toward the upper envelope. The depth of the middle 50% speed profiles was increased after the DSFS until drivers started to react to the lane merge sign when it was decreased again toward the taper area. There was an increase in the upper envelope from the taper point to 400 feet before the speed limit sign. The speeds tended toward the upper envelope from upstream of the taper location to the work area.

The lower envelope and lower extreme was exactly similar for male drivers, while female drivers speeds tended toward the upper extreme with a higher weight on the second quartile at upstream of the first warning sign. Female drivers' speeds were then showed a wider depth in second quartile which were in close proximity with the lower extreme after reacting to the DSFS and continued all the way to the taper area. The male drivers speed tended toward the upper envelope from upstream of the taper to the work area. However, female drivers speed were mainly below the median toward the lower envelope. There were wide gaps between the upper envelope and the upper extreme for both male and female drivers, which was prior to the taper area for male and more obvious after the DSFS for female drivers.

The closed lane middle 50% speeds median was closer to the higher envelope for the majority of the work zone with a higher weight on the third quartile. There was a big gap



between upper envelope and upper extreme for closed lane drivers, while the gap was larger in the lower envelope and extreme for the open lane drivers. There was less variability in the middle 50% depth, but higher extreme and outliers for the open lane drivers.

In short, speeds tended to be toward the higher limit of the 50% depth for male and closed lane drivers, compared to female and open lane drivers.

#### ***4.5.3.3 Vehicle Acceleration Profiles***

The vehicle acceleration for each speed profile in work zone three was calculated from the functional data and were plotted in Figure 4.18. There were two major deceleration points in this work zone. The first major slowdown was after the first warning sign in reaction to the DSFS at 0.4 mile upstream of the taper point which reached the maximum deceleration. The second major deceleration occurred in reaction to the work zone speed limit sign at about 1,000 feet upstream of the work area. The deceleration rate in between the two major one was relatively low. There were few drivers with very high deceleration fluctuations which were repeated frequently throughout the work zone. Overall, the rate of deceleration was high reacting to the safety measure layout in this work zone.

The deceleration magnitude for male and closed lane drivers were observed to be higher than female and open lane drivers. The magnitude of deceleration fluctuations was quite high for closed lane drivers, however, there were two drivers in the open lane who had high deceleration in reaction to the DSFS.

#### ***4.5.3.4 Effectiveness of Safety Measures***

Drivers reacted to the presence of a series of safety features as they approached and travelled through work zone three. Changes in the mean and the associated variability for speed profiles are shown in Table 4.7.

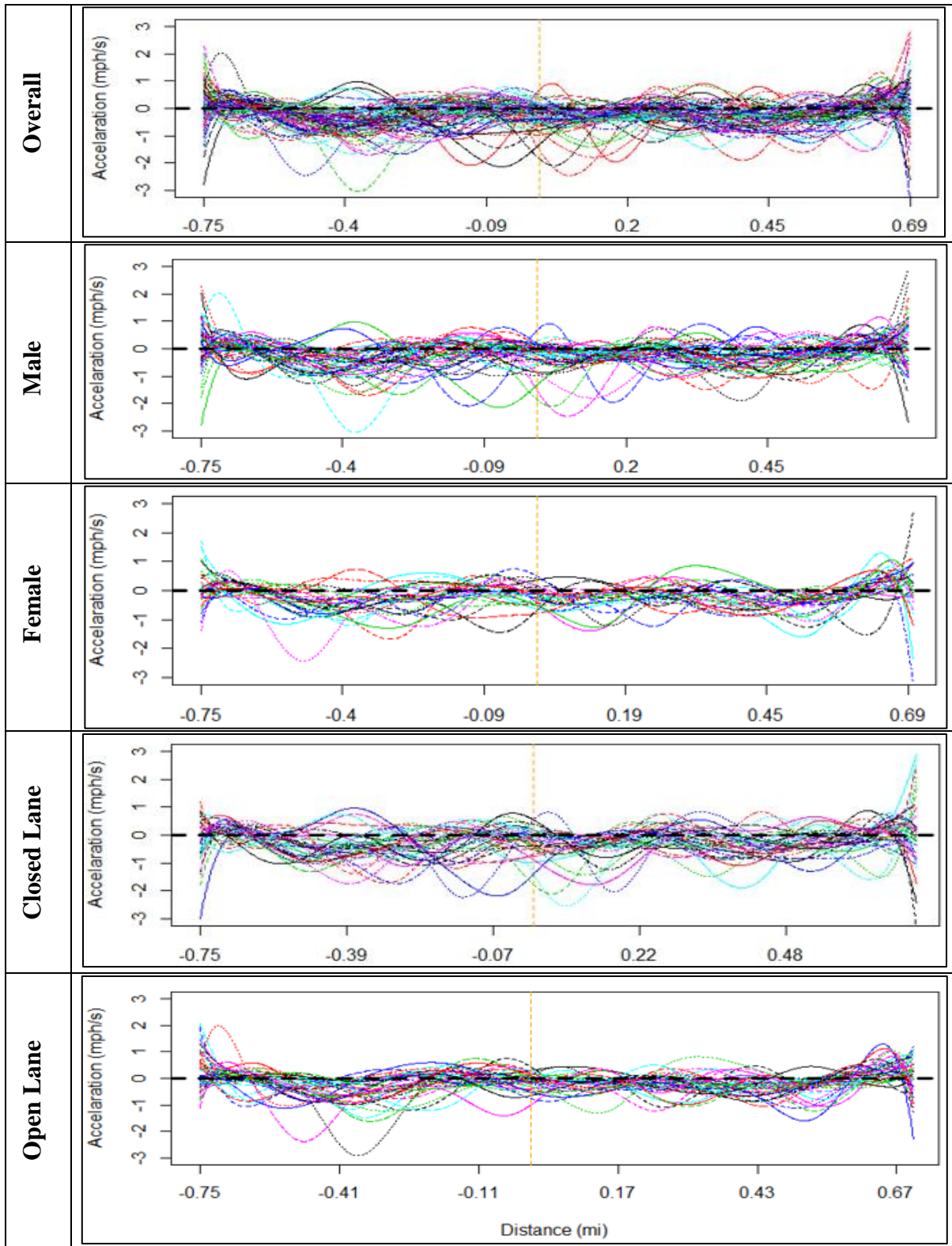

**Figure 4.18 Vehicle acceleration in work zone three with left lane closure and a DSFS after the first warning sign**









legible distance upstream of each safety feature to the feature. The mean speed at the upstream of the work zone first warning sign was around 63 mph for overall, male, and female drivers, while it was higher for closed lane drivers at 66 mph, and lower for open lane drivers at 61 mph. The average mean speed upstream of the first warning sign was about 15% higher than the roadway speed limit of 55 mph.

The first significant reaction was observed upstream of the first work zone warning sign at 3,100 feet upstream of the taper location. The male and closed lane drivers' reactions started at a closer proximity to the taper point at 2,950 and 2,850 feet, respectively. However, open lane and female drivers reacted earlier at 3,250 and 3,000 feet upstream of the taper point, respectively.

The safety features utilized in this work zone were all significant getting drivers to slow down for overall, male, and closed lane drivers. The first three measures, the first warning sign with an attached advisory speed plate of 50 mph, a DSFS, and a second work zone warning sign with an attached advisory speed plate of 45 mph, as well as the speed limit sign and the work area, were all effective to slow the traffic down for all five models in the analysis at 1% significance level. The flashing arrow was significant at the same level for overall, male, and closed lane drivers, while it was significant at 5% level for open lane drivers and was not significant for female drivers.

The standard deviation at the upstream of the first work zone was higher for male drivers compared to any other group. After the first major reaction to the work zone, the first work zone warning sign reduced the speed variability for all groups. The overall speed variation was increased after reacting to the DSFS, specifically for female and closed lane drivers. The increased variation for female drivers was about 162% higher than male drivers.

**Table 4.7 Change in mean speed and standard deviation reacting to work zone three safety features**

Time series speed traces	Functional data summary statistics	1/4 mile upstream of the first warning sign	First significant reaction point upstream of taper (ft)	180 ft upstream of the WZ 1st warning sign	Change in mean speed at the 1st warning sign	450 ft upstream of the DSFS	Change in mean speed at the DSFS	180 ft upstream of WZ 2nd warning sign	Change in mean speed at the 2nd warning sign	270 ft upstream of the merge sign	Change in mean speed at the merge sign	520 ft upstream of the taper	Change in mean speed at the start of taper	600 ft upstream of the flashing arrow sign	Change in mean speed at the flashing arrow sign	450 ft upstream of the WZ speed limit sign	Change in Mean Speed at the WZ speed limit sign	520 ft upstream of the work area	Change in mean speed at the start of the work area
Safety Measure																			
Overall 76 Traces	Mean	63.55	3,100	63.27	-0.81***	62.58	-2.46***	57.46	-0.89***	55.68	-0.56***	54.58	-0.91***	54.46	-1.16***	52.15	-1.91***	49.12	-1.84***
	SD	5.85		5.37	-0.23	5.17	0.23	6.61	0.25	6.99	-0.17	6.29	-0.26	6.23	-0.33	5.88	0.69	6.57	-1.05
	Up. CI	75.02		73.8	-1.25	72.72	-2.02	70.42	-0.4	69.37	-0.89	66.92	-1.42	66.67	-1.81	63.68	-0.56	61.99	-3.88
	Lo. CI	52.08		52.74	-0.36	52.45	-2.91	44.5	-1.38	41.98	-0.23	42.24	-0.4	42.26	-0.52	40.61	-3.25	36.25	0.21
Male Drivers 49 Traces	Mean	63.61	2,950	63.48	-0.73***	62.87	-2.49***	57.46	-0.9***	55.75	-0.48***	54.73	-1.04**	54.59	-1.27***	52.19	-1.93***	49.15	-2.11***
	SD	6.15		5.65	-0.26	5.42	0.06	6.91	0.26	7.21	-0.45	5.91	-0.25	5.85	-0.48	5.35	1.18	6.24	-1
	Up. CI	75.67		74.57	-1.26	73.49	-2.36	71	-0.36	69.87	-1.35	66.32	-1.54	66.06	-2.22	62.68	0.37	61.39	-4.08
	Lo. CI	51.55		52.4	-0.2	52.24	-2.6	43.91	-1.4	41.62	0.4	43.15	-0.55	43.11	-0.31	41.69	-4.22	36.91	-0.14
Female Drivers 27 Traces	Mean	63.43	3,000	62.88	-0.95***	62.07	-2.43***	57.47	-0.91***	55.54	-0.71***	54.32	-0.68	54.24	-0.98	52.08	-1.88***	49.06	-1.34***
	SD	5.38		4.9	-0.17	4.74	0.57	6.17	0.21	6.7	0.36	7.05	-0.27	6.97	-0.11	6.86	-0.08	7.24	-1.17
	Up. CI	73.98		72.48	-1.28	71.36	-1.31	69.56	-0.49	68.7	-0.04	68.14	-1.2	67.9	-1.18	65.52	-2.03	63.26	-3.64
	Lo. CI	52.89		53.29	-0.63	52.79	-3.56	45.37	-1.33	42.42	-1.39	40.49	-0.14	40.58	-0.77	38.64	-1.73	34.87	0.94
Closed lane 37 Traces	Mean	66.01	2,850	65.98	-0.94***	65.18	-2.42***	60.59	-1***	58.4	-0.97***	56.19	-1.36**	55.96	-1.53***	52.89	-2.77***	49.55	-1.87***
	SD	5.33		5.09	-0.09	5	0.49	6.67	0.22	7.02	-0.17	6.27	-0.27	6.2	-0.41	5.82	0.92	6.83	-0.94
	Up. CI	76.54		75.95	-1.11	75	-1.47	73.67	-0.57	72.17	-1.31	68.48	-1.9	68.12	-2.34	64.29	-0.97	62.93	-3.72
	Lo. CI	55.66		56	-0.76	55.38	-3.38	47.51	-1.44	44.64	-0.64	43.91	-0.83	43.8	-0.72	41.49	-4.58	36.16	-0.03
Open lane 39 Traces	Mean	61.13	3,250	60.7	-0.69***	60.12	-2.51***	54.49	-0.79***	53.09	-0.17	53.06	-0.48	53.05	-0.82**	51.44	-1.08***	48.71	-1.79***
	SD	5.34		4.3	-0.3	4.03	-0.07	5.06	0.47	5.95	0.14	6	-0.06	5.99	-0.12	5.93	0.57	6.37	-1.17
	Up. CI	71.59		69.12	-1.28	68	-2.63	64.4	0.14	64.76	0.09	64.84	-0.61	64.78	-1.04	63.07	0.03	61.2	-4.1
	Lo. CI	50.68		52.27	-0.09	52.22	-2.37	44.58	-1.72	41.42	-0.44	41.28	-0.36	41.31	-0.59	39.81	-2.19	36.23	0.51
Significance codes: 0.01%*** 0.05%** 0.1%*																			
SD = Standard Deviation, Up. CI = Upper Confidence Interval, Lo. CI = Lower Confidence Interval																			

Subsequently, the second warning sign caused an increase in speed variability for all groups, which was more pronounced for open lane drivers. The merge sign, the taper location, and the flashing arrow reduced the speed variability for all groups, with the exception of female drivers whose speed variation was increased when reacted to the merge sign. On the contrary, the speed limit sign caused an increase in speed variability for all but female drivers. The speed variation was reduced for all groups in reaction to the work area.

In summary, the safety features' layout in this work zone was very successful to get drivers' attention to slow down from a relatively high speed of over 63 mph at the upstream to the work zone speed limit of 45 mph. The DSFS was found to be the single most effective measure in slowing traffic by as much as 5% in mean speed reduction. Although male drivers had higher speed variability at the upstream of the work zone's first warning sign, their speed variability was the lowest in the work area and was about 15% lower than female drivers.

#### **4.5.4 Right Lane Closure with a DSFS after Work Zone First Warning Sign**

The features of functional data analysis were utilized to identify the underlying process of driver behavior in reaction to various safety features in work zone four for 68 traces from one-quarter mile upstream of the first work zone warning sign (at 0.5 mile upstream of taper) all the way to the work area. The physical location of work zone four along with safety measures layout and location are almost identical to those in work zone 3. The only difference in this work zone is the closure of the right lane instead of the left lane. Therefore, the outside lane is the open lane in this work zone compared to the work zone three.

#### ***4.5.4.1 Mean Speed and Confidence Interval of Functional Objects***

The average mean speed at the upstream of the first warning sign was about 62 mph for the overall model. It was higher for closed lane drivers and lower for open lane drivers as was to be expected. The upstream speed was nearly similar for male and female drivers. The overall model shows the first reaction occurred at about 500 feet upstream of the first work zone warning sign which was located at 500 feet upstream of the DSFS. It was a flat and a steady speed reduction passed the DSFS and up to 300 feet before the second warning sign. The mean speed then remained steady for about 90 feet where drivers reacted to the presence of the taper and flashing arrow at 700 feet upstream of the taper point. The next major speed reduction was to the start of work area at about 700 feet before that.

The first speed reduction for male drivers was after the first warning sign at 350 feet prior to the DSFS until 150 feet after the sign. The male drivers next reaction was at 450 feet upstream of the taper area and the flashing arrow. The female drivers on the other hand reacted to the first sign at about 600 feet upstream of that. The speed reduction continued all the way to 300 feet before the channelization. The next major reaction for female drivers was 600 feet upstream of the the work area.

Closed lane drivers' reaction to the DSFS started at about 300 feet upstream of that, with the next major reaction at 1,100 feet upstream of the taper point, and the last reaction at the start of the work area at 950 feet before that. The open lane drivers reduced their speed rapidly to the presence of the first warning sign and the DSFS, which continued until after the second warning sign. The mean speed then remained constant until after the flashing arrow sign, where they started to react gradually to the presence of the work area.

The confidence interval for the overall model was about 11.75 mph upstream of the first warning sign, increasing to 12.5 mph after reacting to first two safety measures, 14.75 mph upstream of the flashing arrow, and then decreasing to 12 mph after reacting to the work area. The confidence interval was 11.7 and 10.4 mph after their first significant reactions upstream of the first warning sign, 12.7 and 11.4 mph after the first two safety features, 14.6 and 13.4 mph upstream of the flashing arrow, and 13.5 and 7.5 mph at the work area for male and female drivers, respectively. The open lane confidence interval was about 20% higher upstream of the first sign and 38% higher at the work area than for closed lane drivers.

#### ***4.5.4.2 Functional Boxplots***

The overall model functional boxplot reveals an equal spread of speeds above and below the median from upstream of the first warning sign to the taper area and then tends more toward the upper envelope in reaction to the flashing arrow, the speed limit sign, and the work area. There was a larger gap between the upper envelope and the extreme compared to lower envelope and the extreme up to the work area reaction point.

The middle 50% depth is wider for male drivers from the upstream of the first sign to the second warning sign compared to female drivers. The male drivers' speeds weighted more toward the upper envelope, while female drivers' speeds tended toward the lower envelope and below the median from upstream of the first sign to the start of the taper. The middle 50% depth for female drivers shows a higher variability from the taper location to the work area, however, male drivers' speed profiles show a narrower middle 50% depth variability and higher extremes for the same distance. There was a high variability for female drivers' median speed compared to male drivers. The functional boxplot shows an outlier for male drivers speed profiles.

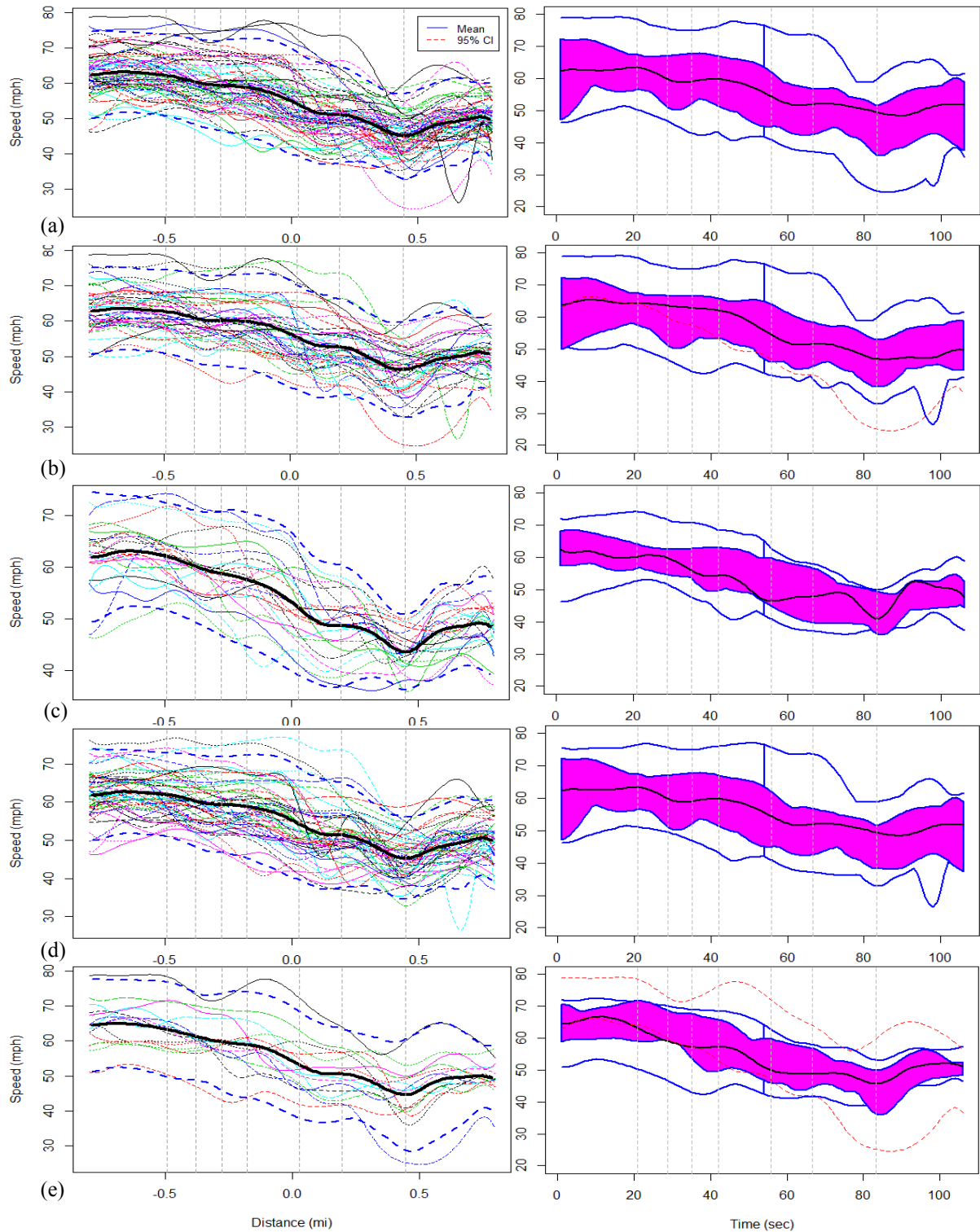

**Figure 4.19 Plots of mean speed, confidence interval, and functional boxplot in work zone four**

Left panel. Plot of mean speed and confidence interval for speed time series traces for overall (a), male drivers (b), female drivers (c), closed lane (d), and open lane (e) traces. Right panel. Plots of functional boxplots for the corresponding categories to the left



There were considerable gaps in between envelopes and extremes on both ends, with larger gaps for the upper envelope and extreme for the male and closed lane drivers throughout the work zone.

The open lane speed profiles show a negligible gap between the upper envelope and the extreme, but a large gap for the lower envelope and the extreme from upstream of the first sign to the point of reaction to the work area. The closed lane speeds equally spread on both sides of the median with higher tendencies to the upper side after the speed limit sign to the work area, however, the tendency was toward the lower side of median in the majority of the work zone for open lane speed profiles. The median for open lane presents a high variability compared to closed lane speed traces. The depth of the middle 50% speed is narrower for open lane when compared to closed lane speed profiles. The functional boxplot for open lane speed traces shows two outliers, while the closed lane profiles contain no outliers.

#### ***4.5.4.3 Vehicle Acceleration Profiles***

The vehicle acceleration for each speed profile in work zone four was calculated from the functional data and were plotted in Figure 4.20. There were three locations with relatively higher deceleration rates. The three major deceleration happened in reaction to the DSFS, the taper area, and the work area, however the deceleration magnitude at the DSFS was not as high as the other two. There were few outliers which had high deceleration rates at the taper and work areas.

The deceleration changed into acceleration after drivers entered the designated work area with no activity at the start of the work area, however, there was the presence of equipment and workers further down the work area which caused a substantial deceleration.

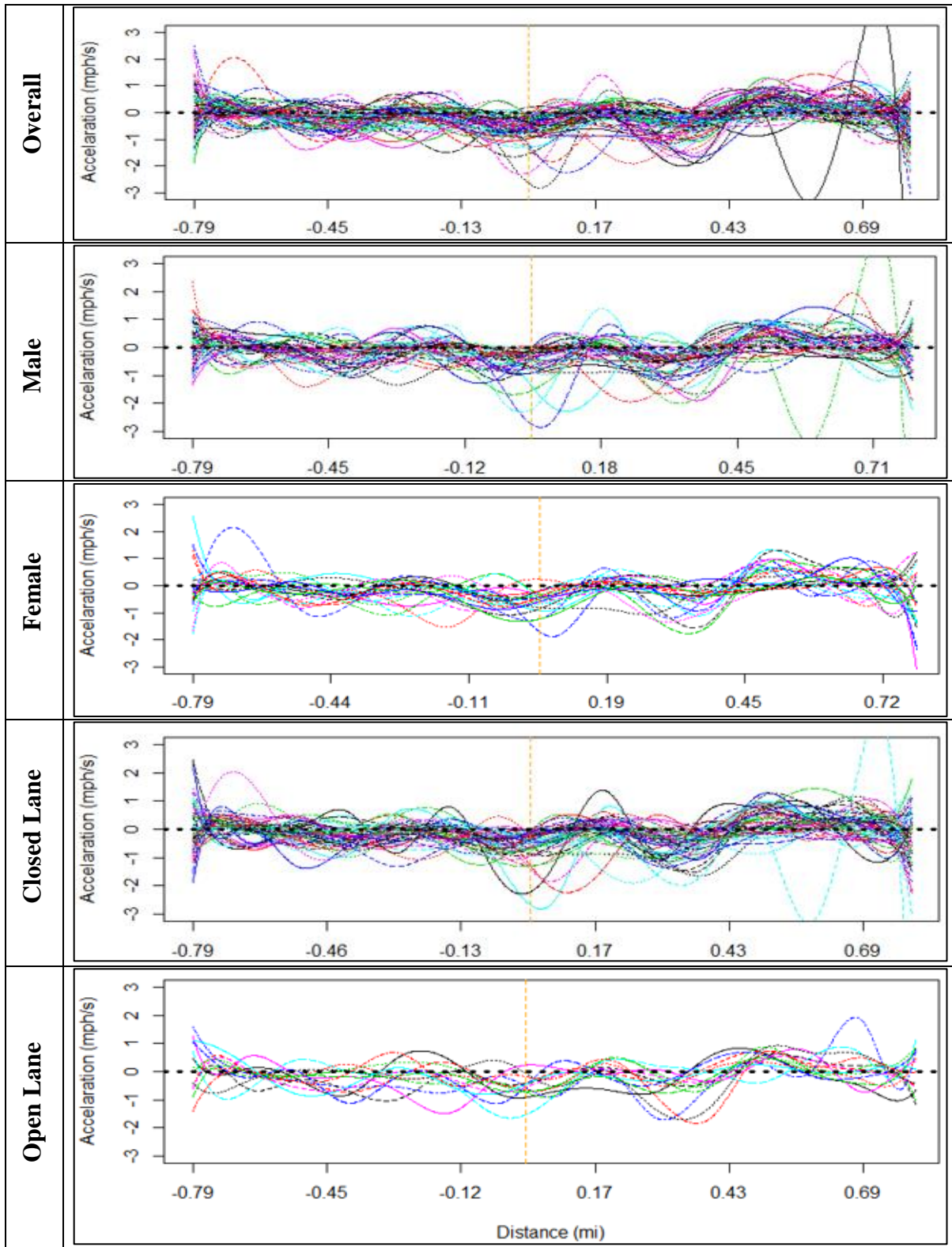

**Figure 4.20 Vehicle acceleration in work zone four with a right lane closure and a DSFS after the first warning sign**

The most obvious outliers were five male drivers who drove in the closed lane and had a high fluctuations throughout the work zone with higher deceleration rates at the taper and work areas. One male driver showed an extremely high deceleration and acceleration rates of  $\pm 3$  mph per second in the vicinity of the work area. Overall, the deceleration rate was high in reaction to the safety measure layout in this work zone with a high sinusoidal waves.

There were a few female drivers with high deceleration fluctuations behavior, but the magnitude of that was not as high as that for male drivers. The deceleration fluctuations were significantly higher for male and closed lane drivers.









#### ***4.5.4.4 Effectiveness of Safety Measures***

Changes in mean and the associated variations for speed profiles, as drivers approached and travelled through work zone 4, with an identified set of safety measures, are shown in Table 4.8. The change in mean speed was calculated from a legible distance upstream of each countermeasure.

The first significant reaction was observed at the upstream of the first work zone warning sign at 3,150 feet upstream of the taper location. The male and closed lane drivers' reactions started later at 3,100 and 3,000 feet upstream of the taper point, respectively. However, open lane and female drivers reacted earlier at 3,400 and 3,300 feet upstream of the taper, respectively.

The first work zone warning sign with the attached 50 mph advisory plate was effective in reducing the mean speed at 5% significance level for all groups. The DSFS had a higher effectiveness in reducing the mean speed for all groups at 1% significance level. The second warning sign with the attached 45 mph advisory plate was only effective in reducing open lane drivers' mean speed at 5% significance level.

**Table 4.8 Change in mean speed and standard deviation reacting to work zone four safety features**

Time series speed traces	Functional data summary statistics	1/4 mile upstream of first warning sign	First significant reaction point upstream of taper (ft)	180 ft upstream of WZ 1st warning sign	Change in mean speed at the 1st warning sign	450 ft upstream of the DSFS	Change in mean speed at the DSFS	180 ft upstream of WZ 2nd warning sign	Change in mean speed at the 2nd warning sign	270 ft upstream of the merge sign	Change in mean speed at the merge sign	520 ft upstream of the taper	Change in mean speed at the start of taper	600 ft upstream of the flashing arrow sign	Change in mean speed at the flashing arrow sign	450 ft upstream of the WZ speed limit sign	Change in Mean Speed at the WZ speed limit sign	520 ft upstream of the work area	Change in mean speed at the start of work area
Safety Measure																			
Overall 68 Traces	Mean	62.76	3,150	62.56	-0.27***	61.99	-1.51***	59.59	-0.2*	59.19	-0.31**	57.79	-2.72***	57.54	-3.31***	51.66	0.53	47.62	-2.46***
	SD	6.12		5.83	0.05	5.95	0.22	6.36	0.16	6.8	0.23	7.46	0.19	7.52	0	7.34	-0.43	5.8	0.33
	Up. CI	74.75		73.98	-0.16	73.66	-1.08	72.07	0.1	72.52	0.13	72.41	-2.34	72.28	-3.32	66.05	-1.37	58.99	-1.82
	Lo. CI	50.77		51.13	-0.37	50.33	-1.95	47.12	-0.51	45.86	-0.77	43.17	-3.11	42.81	-3.31	37.28	0.31	36.24	-3.1
Male Drivers 44 Traces	Mean	63.17	3,100	62.88	-0.19**	62.43	-1.51***	60.12	-0.09	60.02	-0.12	59	-2.66***	58.76	-3.23***	53.11	-0.45	48.37	-2.17***
	SD	6.18		5.96	0.08	6.12	0.27	6.5	0.03	6.67	0.19	7.35	0.38	7.43	0.17	7.55	-0.58	6.45	0.44
	Up. CI	75.28		74.56	-0.04	74.43	-0.98	72.85	-0.02	73.1	0.24	73.4	-1.9	73.33	-2.89	67.92	-1.59	61.01	-1.3
	Lo. CI	51.07		51.21	-0.36	50.43	-2.03	47.38	-0.16	46.94	-0.49	44.6	-3.41	44.2	-3.58	38.3	0.69	35.72	-3.04
Female Drivers 24 Traces	Mean	62.21	3,300	62.41	-0.39**	61.64	-1.53***	59.08	-0.38	58.23	-0.63**	56.17	-2.96***	55.89	-3.6***	49.31	-0.73**	46.44	-2.89***
	SD	6.1		5.32	-0.02	5.33	0.18	5.82	0.31	6.52	0.08	6.81	0.05	6.84	-0.15	6.14	-0.15	4.04	-0.32
	Up. CI	74.17		72.85	-0.44	72.1	-1.18	70.5	0.22	71	-0.45	69.51	-2.86	69.29	-3.89	61.34	-1.03	54.36	-3.52
	Lo. CI	50.25		51.97	-0.34	51.2	-1.89	47.67	-0.98	45.46	-0.8	42.82	-3.05	42.48	-3.3	37.28	-0.43	38.51	-2.26
Closed lane 53 Traces	Mean	62.18	3,000	62.2	-0.2**	61.74	-1.5***	59.42	-0.14	59.17	-0.31**	57.81	-2.51***	57.59	-3.11***	51.88	-0.55	47.72	-2.36***
	SD	5.92		5.54	0.04	5.68	0.47	6.34	0.06	6.6	0.28	7.4	0.23	7.47	0.01	7.39	-0.37	5.53	-0.01
	Up. CI	73.78		73.06	-0.12	72.87	-0.58	71.85	-0.01	72.11	0.24	72.31	-2.05	72.22	-3.07	66.36	-1.25	58.57	-2.4
	Lo. CI	50.57		51.33	-0.28	50.61	-2.41	46.99	-0.26	46.22	-0.85	43.31	-2.98	42.95	-3.15	37.4	0.16	36.88	-2.33
Open lane 15 Traces	Mean	64.81	3,400	63.82	-0.49**	62.89	-1.56***	60.2	-0.45**	59.3	-0.37	57.71	-3.44***	57.38	-4.01***	50.87	-0.41	47.14	-2.58***
	SD	6.56		6.81	0.14	6.97	-0.56	6.62	0.5	7.67	0.09	7.93	0.02	7.95	-0.11	7.34	-0.67	6.89	1.2
	Up. CI	77.67		77.17	-0.22	76.55	-2.66	73.19	0.52	74.34	-0.2	73.25	-3.39	72.96	-4.23	65.26	-1.72	60.65	-0.23
	Lo. CI	51.95		50.47	-0.76	49.23	-0.46	47.22	-1.44	44.25	-0.52	42.16	-3.47	41.8	-3.79	36.48	0.9	33.62	-4.93
Significance codes: 0.01% *** 0.05% ** 0.1% *																			
SD = Standard Deviation, Up. CI = Upper Confidence Interval, Lo. CI = Lower Confidence Interval																			

The lane merge sign was effective in reducing speed for overall, female, and open lane drivers at 5% significance level. The taper location, the flashing arrow, and the work area were all substantially effective in reducing speed at 1% significance level. The speed limit sign was successful in reducing female drivers' mean speed at 95% confidence level.

The first work zone warning sign, along with the DSFS, were not able to reduce speed variability for overall, male, female and closed lane drivers, however, the DSFS was able to reduce speed variation for open lane drivers. Male drivers' speed variability was higher in reaction to the DSFS compared to female drivers. The speed variability was increased at the second warning sign with an attached 45 mph advisory plate, a merge sign with attached 45 mph advisory plate, and the taper location. There were mixed results for variability changes in reaction to the flashing arrow. The speed variation was slightly reduced for female and open lane drivers, slightly increased for male drivers, and resulted in no change for the overall and closed lane drivers. The speed limit sign was very effective in reducing the variability for all groups. The speed variation at the work area was increased for all groups with the exceptions of female and open lane drivers.

In short, the first two signs were significantly effective to encourage safe work zone driving, while the second warning sign was not significant at the same level. All the remaining safety features from the right lane closed sign to the work area were all highly effective in reducing the mean speed for the overall model. The condition was somehow different on speed variation, as the speed limit sign was the only effective sign to reduce the speed variability.

#### 4.5.5 Lane Shift

Various methods of functional data analysis were used to identify the underlying process of driver behavior reacting to safety features and summarized similarities and differences of 37 traces in work zone five from one-quarter mile upstream of the first work zone warning sign (at 1.1 miles upstream of the taper) all the way to the work area. The work zone speed limit was 55 mph, which is similar to that for the roadway. A series of safety features applied in this work zone included a first work zone warning sign, a highway guide sign, barrels tapering the shoulder, and lane shift with an attached both shoulder closed sign at -1.1, -0.4, -0.2, and -0.1 miles from the start of the taper, respectively.

##### *4.5.5.1 Mean Speed and Confidence Interval of Functional Objects*

The average mean speed was about 62 mph for the overall model. It was higher for female drivers and lower for male drivers compared to overall model. The overall model shows a slight reaction to the work zone first warning sign at 1.1 miles upstream of the lane shift location. There was an increase in the mean speed between the first and second signs up to 1,000 feet upstream of the highway guide sign, where the first major reaction occurred. There was a slight increase in the mean speed after the highway guide sign up to 250 feet upstream of the lane shift sign, where the mean speed was reduced in reaction to the lane shift.

The first slight reaction for male drivers was at 750 feet before the highway guide sign. The female drivers, on the other hand, had a significant speed reduction to the highway guide sign at about 1,100 feet prior to that. Female drivers then had a period of speed increase before their next major reaction at about 400 feet upstream of the lane shift location.

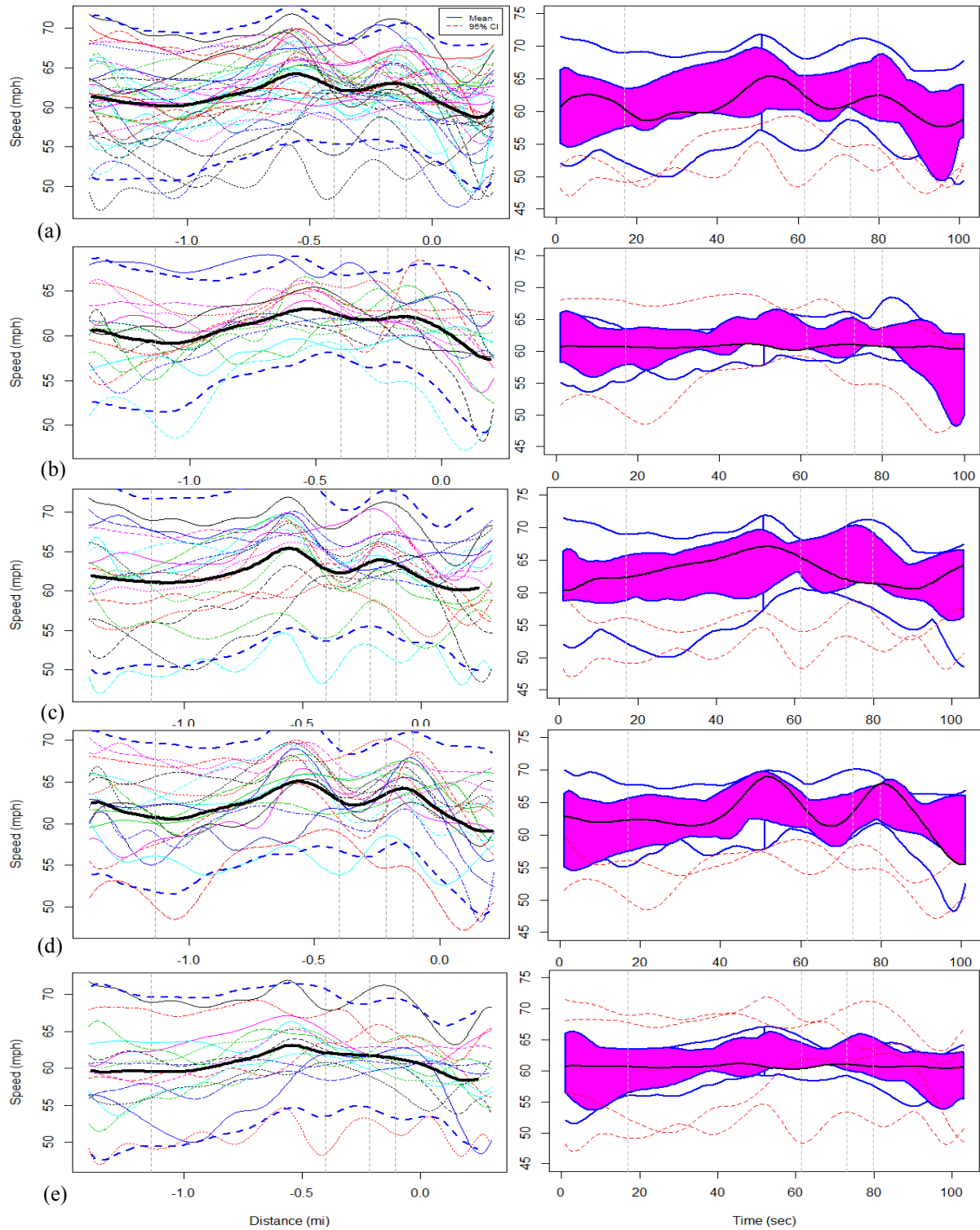

**Figure 4.21** Plots of mean speed, confidence interval, and functional boxplot in work zone five

Left panel. Plot of mean speed and confidence interval for speed time series traces in work zone 4 for overall (a), male drivers (b), female drivers (c), closed lane (d), and open lane (e) traces. Right panel. Functional boxplots for the corresponding categories to the left

Closed lane drivers reacted to the presence of the guide sign in a closer proximity with a rapid speed reduction compared to open lane drivers. The closed lane drivers then had a period of speed increase before reacting to the lane shift at 200 feet prior to that, however, open lane drivers had an earlier and steadier speed reduction in reaction to the highway guide sign, which was continued to the lane shift location.

The confidence interval at 9.6 mph was higher for female drivers, after their first significant reaction to the work zone at the upstream of the highway guide sign, compared to 4.5 mph for female drivers (more than two times higher) and became about 8.3 mph at the lane shift area compared to 7.1 mph for male drivers (15% higher). The open lane drivers had a higher confidence interval of 8.8 mph upstream of the highway guide sign compared to 6.3 mph for closed lane drivers, however, it became higher for closed lane drivers at the lane shift area, 8.1 and 7.2 mph for closed and open lane drivers, respectively.

#### ***4.5.5.2 Functional Boxplots***

The functional boxplot for the overall model demonstrates variations in middle 50% depth and both extremes, however, the depth of variation is narrower compared to work zone with lane closure scenarios. The middle 50% depth was getting narrower in reaction to the first warning sign and remained almost the same until reached the lane shift area, then became wider again. The median speed showed a significant fluctuation inside a narrow range. There is a large gap between both envelopes and extremes from upstream of the first sign to the first significant reaction upstream of the highway guide sign. A significant speed variations was observed at the lower extreme. There are two outliers which are shown in the functional boxplot for the overall model.



The male drivers' median speed showed almost no variation for the entire work zone. The upper envelope and extreme are the same from upstream of the first sign all the way to the first major reaction location upstream of the highway guide sign, however, there is a small gap between the lower envelope and the extreme for the entire work zone excluding the work area. The middle 50% depth for female drivers is wider than that for male drivers. The gap between the two extremes is very wide from upstream of the first sign to the first major reaction point for female drivers compared to that for male drivers. The functional boxplots for both genders show two outliers.

The functional boxplot for closed lane traces shows fluctuations in median speed from the middle point between the first warning sign and highway guide sign all the way to the work area. The speed profiles weighted more toward the third quartile and the median speed tended toward the upper envelope for the majority of the work zone. The median speed of the open lane traces, on the other hand, showed minimal variability for the entire work zone. The upper envelope and extreme are almost the same for the whole work zone for open lane traces. The functional boxplots for closed lane and open lane speed traces present two and four outliers, respectively.

#### ***4.5.5.3 Vehicle Acceleration Profiles***

The vehicle acceleration for each speed profile in work zone five with a lane shift scenario was calculated from the functional data and were plotted in Figure 4.22. The first major deceleration was in reaction to highway guide sign at about 0.4 miles upstream of the lane shift location. The second significant deceleration was occurred in reaction to the start of the lane shift at about 500 feet upstream of that.

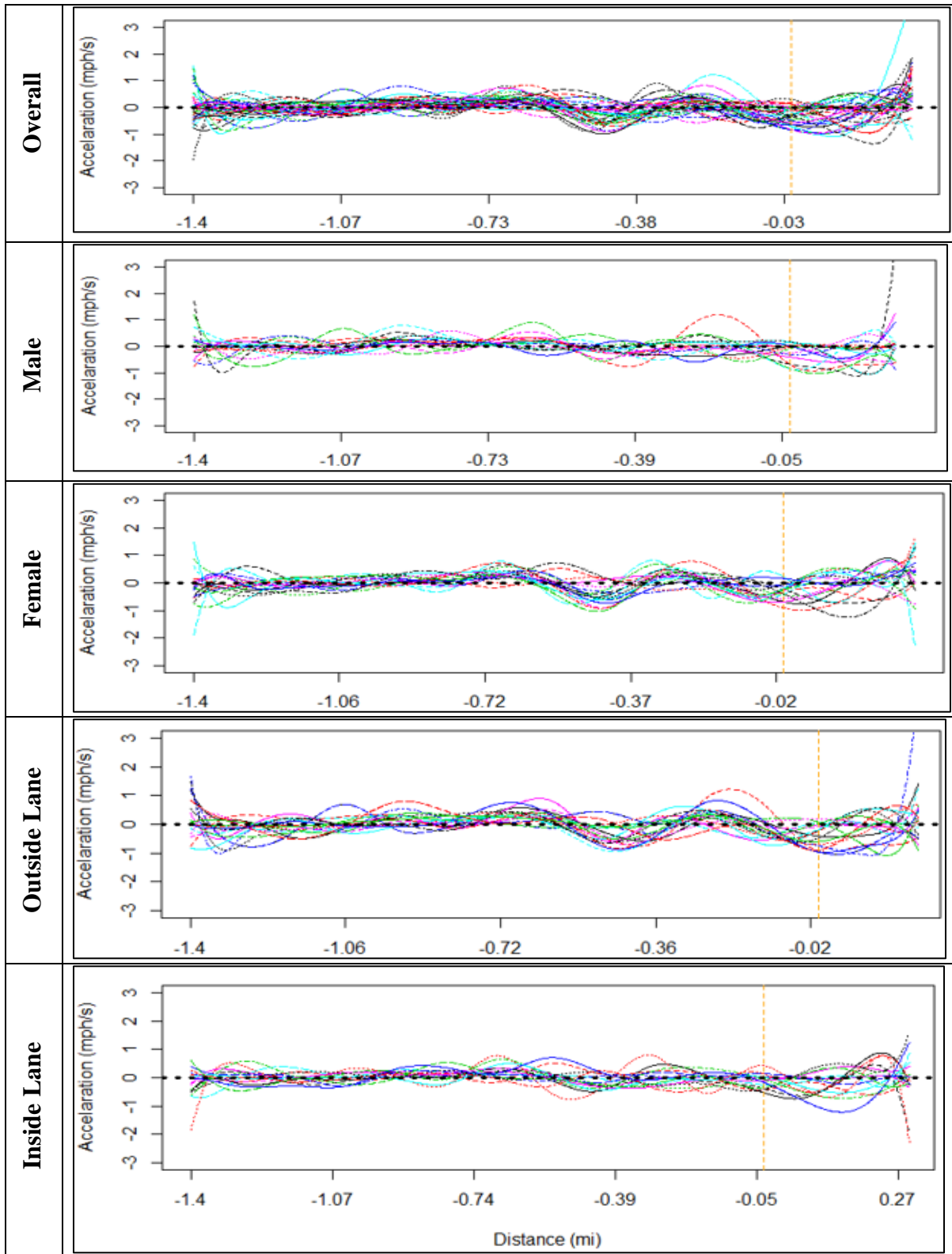

Figure 4.22 Vehicle deceleration in work zone five with a lane shift and both shoulders closure

The deceleration phenomenon was less significant in the work zone with a lane shift situation, however, there were one or two outliers than other drivers.

The deceleration magnitude for female and closed lane drivers was slightly higher than that for male and open lane drivers at the highway guide sign and at the location of the lane shift.





#### ***4.5.5.4 Effectiveness of Safety Measures***

Drivers reacted to the presence of a series of safety features as they approached and travelled through work zone five. Changes in mean and the associated variations for speed profiles are shown in Table 4.9. The change in mean speed was calculated from a legible distance upstream of each feature.

The work zone's first warning sign at 1.14 miles upstream of the lane shift location had no major effect on drivers to reduce their speed. The first significant reaction was identified to be at 2,850 feet upstream of the lane shift location for the overall model. The male and female drivers reacted at 2,700 and 2,900 feet upstream of the lane shift point, respectively.

The first major reaction was to the highway guide sign which had a very significant effect in reducing the mean speed for all groups at 1% significance level. The presence of barrels which tapered the left shoulder was not significant in slowing the traffic down, and in fact the mean speed increased at that location. The lane shift sign with indication of both shoulders closed was only effective on female drivers in reducing their speed at 1% significance level. The start of the lane shift was highly significant in reducing the mean speed for overall, female, and closed lane drivers at 99% confidence level, and slightly less significant for male and open lane drivers at 5% significance level.

**Table 4.9 Change in mean speed and standard deviation reacting to work zone five safety features**

Time series speed traces	Functional data summary statistics	1/4 mile upstream of first warning sign	180 ft upstream of the WZ 1st warning sign	Change in mean speed at the 1st warning sign	First significant reaction point upstream of taper (ft)	180 ft upstream of the guide sign	Change in mean speed at the guide sign	520 ft upstream of barrels closed left shoulder	Change in mean speed at the shoulder taper	270 ft upstream of lane shift both shoulder closed sign	Change in mean speed at the lane shift both shoulder closed sign	520 ft upstream of lane shift location	Change in mean speed at the start of lane shift
Safety Measure													
Overall 62 Traces	Mean	61.29	60.33	-0.09*	2,850	62.96	-0.44***	62.08	0.73	63.01	-0.24	62.71	-1.53***
	SD	5.25	4.77	-0.01		3.83	-0.16	3.36	0.18	3.8	0.2	4.02	-0.1
	Up. CI	71.58	69.68	-0.11		70.46	-0.75	68.65	1.1	70.47	0.16	70.59	-1.71
	Lo. CI	50.1	50.1	0.8		55.47	-0.15	55.5	0.37	55.55	-0.63	54.84	-1.35
Male Drivers 29 Traces	Mean	60.62	59.44	-0.14	2,700	62.54	-0.28***	61.78	0.19	62.16	-0.14	61.98	-1.24**
	SD	4.1	3.99	-0.01		2.28	-0.03	2.65	-0.09	2.7	0.34	3.07	0.54
	Up. CI	68.67	67.27	-0.17		67.02	-0.24	66.98	-0.01	67.45	0.53	68	-0.18
	Lo. CI	52.57	51.62	-0.11		58.06	-0.33	56.57	0.37	56.87	-0.81	55.95	-2.29
Female Drivers 33 Traces	Mean	61.92	61.17	-0.1	2,900	63.34	-0.59***	62.34	1.31	63.91	-0.5***	63.32	-1.64***
	SD	6.19	5.38	-0.01		4.88	-0.2	3.99	0.16	4.5	0.21	4.72	-0.48
	Up. CI	74.06	71.72	-0.08		72.91	-0.98	70.15	1.61	72.73	-0.08	72.58	-2.59
	Lo. CI	49.77	50.62	-0.06		53.77	-0.21	54.52	1.02	55.08	-0.91	54.06	-0.69
Closed lane 26 Traces	Mean	62.55	60.9	-0.16*	2,850	63.44	-0.64***	62.29	1.26	64.21	-0.32	63.79	-2.2***
	SD	4.39	4.48	0.05		3.23	-0.14	3.21	0.08	3.33	0.29	3.66	0.47
	Up. CI	71.16	69.69	-0.08		69.77	-0.91	68.6	1.41	70.73	0.26	70.96	-1.28
	Lo. CI	53.95	52.12	-0.26		57.1	-0.35	55.99	1.11	57.68	-0.89	56.62	-3.13
Open lane 36 Traces	Mean	59.63	59.6	-0.03	2,750	62.32	-0.22***	61.86	-0.13	61.57	-0.2*	61.33	-0.71**
	SD	5.95	5.18	-0.03		4.51	-0.1	3.68	-0.08	3.95	0.2	4.16	-0.47
	Up. CI	71.29	69.76	-0.1		71.17	-0.42	69.07	-0.28	69.32	0.18	69.48	-1.62
	Lo. CI	47.98	49.45	0.03		53.48	-0.03	54.66	0	53.83	-0.59	53.19	0.19
Significance codes: 0.01% *** 0.05% ** 0.1% *													
SD = Standard Deviation, Up. CI = Upper Confidence Interval, Lo. CI = Lower Confidence Interval													

The standard deviation at upstream of the first warning sign was about 40% higher for female drivers compared to their male counterparts. It was also 30% higher for the open lane drivers compared to the closed lane drivers. The first warning sign didn't have any effect on speed variation. The highway guide sign was effective in reducing the speed variation for all groups.

The speed variation was increased at the barrels' location for overall, female, and closed lane drivers, while slightly decreased for female and open lane drivers. The lane shift sign caused an increase in speed variability for all groups. The start of the lane shift had mixed effects on speed variation, increasing speed variability for male and closed lane drivers, and decreasing the speed variation for overall, female, and open lane drivers.

In short, the highway guide sign and the start of the lane shift were both effective encouraging drivers to slow down. The speed variability was higher for female and open lane drivers compared to male and closed lane drivers from upstream all the way through the lane shift location.

#### **4.6 Summary and Discussion**

The objective of this research was to identify where drivers started to react to the presence of a work zone and to assess the effectiveness of safety features utilized to encourage drivers to safely traverse the work zone. This was done by using the tools of FDA to analyze high frequency speed time series from work zones in SHRP 2 NDS data with various characteristics and a smooth underlying process. The FDA is extremely useful to describe a complex process of drivers' interactions with various safety measures in the work zone environment which could not be explained by a simple parametric model. The statistical methods of the FDA were used to summarize an average drivers' behavior to investigate their

reaction to a series of safety features and evaluate the effectiveness of those features individually or collectively.

The FDA involved several process including the smoothing to convert the raw discrete time series data to functional data. The smoothing process of FDA analysis is important to remove large noises from the raw data which helps to identify the unbiased average driver behavior for a series of repeated speed time series profiles.

The study investigated behavior of 131 unique drivers with 285 time series speed profiles over 5 different work zones, including left or right lane closures and lane shift scenarios, with various traffic control layouts. There was a 10 mph speed reduction required for all work zones with the lane closure and no speed reduction for the lane shift scenario.

The conclusions of this research study could provide implications to transportation agencies about the effectiveness of safety measures and traffic control layouts in work zones. The findings can also provide recommendations about the most effective countermeasures and safety features layout that can improve safety in work zones.

#### **4.6.1 Mean Speed and Safety Feature Effectiveness**

The reduction in mean speed from a legible or visible distance of a feature was used to identify the effectiveness of the measure on driver behavior. The legible distance was used to identify the effectiveness of an individual countermeasure from an identified distance that the change in mean speed can be attributed to the presence of that feature. The plot of mean speeds at the safety feature locations for the overall and subset categories in 5 work zones are shown in the left panel of Figure 4.23. The plots are showing the driving path from upstream all the way to the work area and the interaction of drivers with a series of safety features in

multiple work zones. A cursory glance at all 5 work zones shows no major reactions occurred until approximately half a mile upstream of the taper location.

One sample t-test was conducted to test the null hypothesis stating the change in mean speed from upstream of a sign to the location of the sign is equal to zero at 95% confidence level. The models for work zones with a closed lane scenarios revealed significant reactions to the first warning signs when an advisory speed plate was attached to it for overall and all sub-categories. The first warning sign at about one mile upstream of taper had a significant influence on speed reductions of female and open lane drivers in work zone one. The reaction to the first sign in the lane shift scenario at over one mile upstream of the taper location was somehow different. The male and closed lane drivers' reaction were more significant than female and open lane drivers. There was an increase in the mean speed between the first and second warning sign distanced at about 3,900 feet. The increase in mean speed might be due to no construction activity observed by drivers.

There were significant reactions to the presence of the DSFS for overall and similarly for all other sub groups for both left and right lane closure scenarios, however, the effectiveness of the DSFS was 50% higher when applied in the left lane closed work zone. The DSFS effectiveness was higher than any other safety features applied in work zones to capture drivers' attention.

The DMS was only effective in slowing down the female and open lane drivers when applied at a long distance upstream of the taper point, however, it was more significant when applied at a closer proximity to the taper location, for male and closed lane drivers in particular.

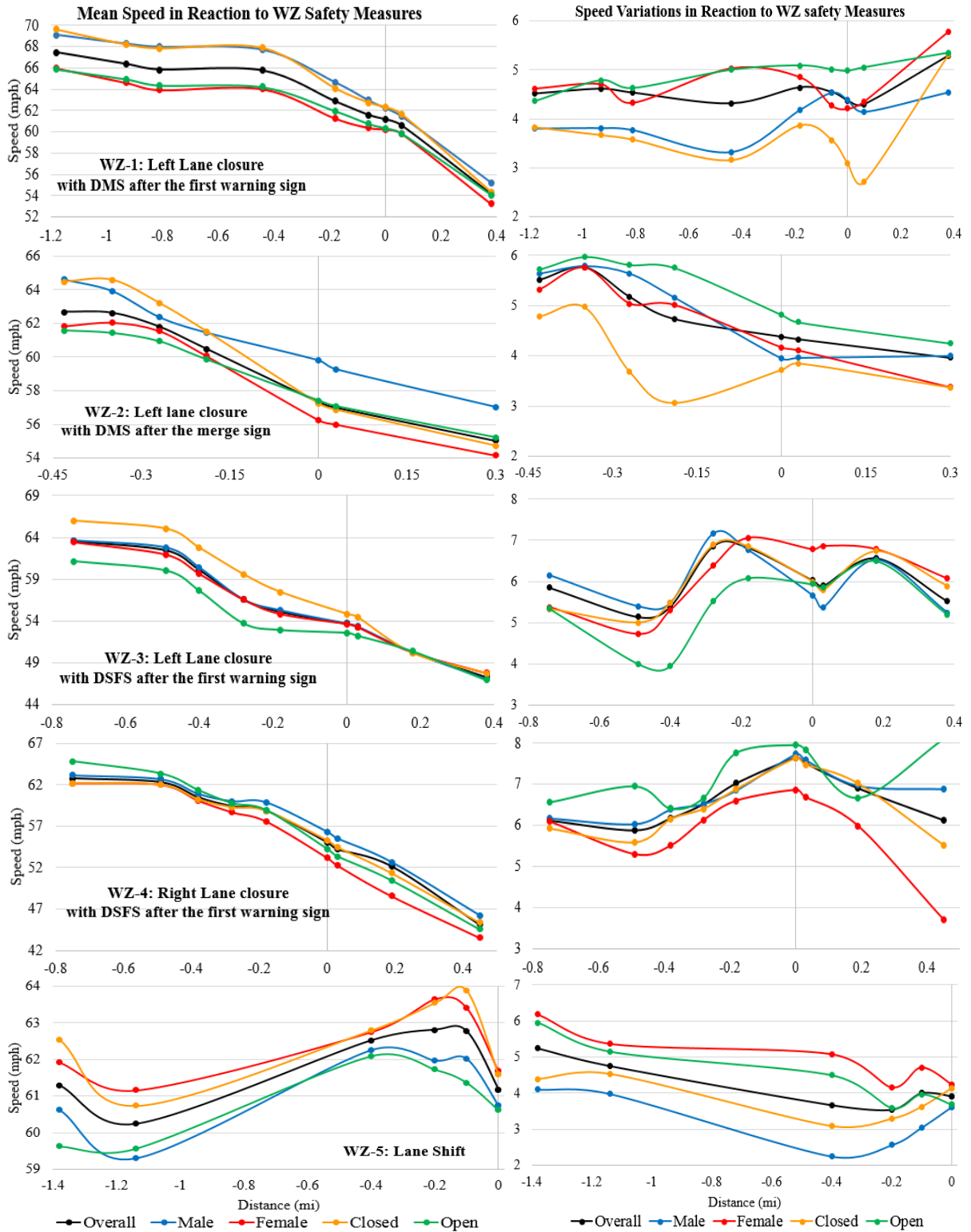

**Figure 4.23 Plot of mean speed and standard deviation at safety features**

Left panel. Plot of mean speed at safety features for speed profiles of all involved groups in work zones 1 to 5 from top to bottom. Right panel. Plot of standard deviation at safety features for all groups in the corresponding work zone to the left



The lane merge sign was found to be significantly effective in reducing the mean speed when utilized in a closer proximity to the taper area at less than 1,000 feet distance, with the exception of open lane drivers in work zone three. The lane merge sign was only significantly effective on male drivers when applied farther from the taper at about 1,900 feet.

The static work zone speed limit sign was substantially effective in reducing speed when applied right before the taper point, however, it was significantly effective in work zone three when applied at 1,100 feet upstream of the work area. The start of the taper and flashing arrow were found to be very significant in reducing the mean speed for the overall models in work zones with left lane closure scenarios. The work area was found to be extremely significant for the overall and all sub category models.

#### **4.6.2 Risks Associated with Speed Variations**

Past research indicated excessive speed and speed variation are the main contributing factors to work zone crashes. The results of the study in chapter 2 also confirmed the fact that speed and speed variability significantly contributed to the occurrence of the safety critical events in work zones. The results of standard deviations at the location of safety features were plotted and shown in the right panel of Figure 4.23.

The standard deviation needed to be checked to see if it was increased or decreased by the presence of each safety measure. An increase in standard deviation in reaction to the safety feature could adversely affect the safety and a decrease in standard deviation could be a positive outcome for safety.

The standard deviation upstream of the work zones varied between 3.8 and 6.7 mph for all five work zones in the study. It was between 3.8 to 4.8 mph for the work zone one and

6 to 6.7 mph for work zone four as the low and the high, respectively. There was a small reduction in speed variation at the work zone's first warning sign and DMS when applied immediately after the first sign. This was the case for the second warning sign as well.

The presence of a DSFS in both the left and right lane closures caused an increase in variability of 0.06 to 0.57 mph for male and female drivers, respectively. The presence of a DMS after the lane merge sign however, was effective in reducing the speed dispersion by 0.71 mph for the overall model. The extremes were 1.41 mph for closed lane drivers and -0.17 for male drivers. The standard deviation after the DSFS was increased in reaction to the second warning sign.

The lane merge sign mainly caused a small increase in speed variation and the effect of that on male and female drivers was mixed in different work zones. Even though it was effective in reducing the speed dispersion when it was applied with an attached speed advisory plate in the left lane closed situation, it had the opposite effect at the right lane closure scenario. This might be due to the fact that outside lane drivers, who usually drive at a higher speed, didn't need to merge into the inside or open lane in this case.

The static speed limit sign in the left closure work zones causes a reduction in speed variations for most of the scenarios. It caused an increase in the case of the left lane closure when applied 1,300 feet upstream of the work area, however, had the opposite effect in the case of right lane closure at similar location.

The start of the taper and the flashing arrow caused a decrease in the standard deviation in the majority of scenarios, however, a small increase was observed in the right lane closure case. There was a mixed effect on the work area concerning speed dispersion.

The variation decreased by as much as 18% in work zone three and increased by about 6% in work zone one for the overall models.

The informative exploratory feature of functional boxplot provided a solid range of data for analyzing driver behavior in reaction to various safety features in work zones. The investigation of functional boxplots revealed the central 50% depth was wider for female and open lane drivers. It was observed that male and closed lane drivers' speeds have a higher concentration above the median when the median speed have a higher tendency toward the upper envelope. The plots also showed a high median variations for closed lane drivers, while open lane drivers revealed higher extremes. The lane shift scenario showed a narrower middle depth and lower extremes, however, introduced more outliers.

#### **4.6.3 Vehicle mean deceleration profiles in work zones**

The average deceleration profiles for all work zones in the study are shown in Figure 4.24. There are three curves on the plot. The female, male, and overall drivers' deceleration profiles are represented by a solid red line, a solid blue line, and a dotted black line, respectively. The orange dashed lines are the locations of safety features in each work zone. The average deceleration rates provided very useful visual aids to see how drivers reduced their speed in reaction to each safety feature utilized in the work zone for that purpose.

There were varying deceleration magnitudes in reaction to various features. The rate was lower in reaction to the first warning sign and the DMS when it was applied at about one mile upstream of the taper point in work zone one. However, the magnitude of deceleration was significantly decreased in reaction to the DMS when it was in a closer proximity to the taper location.

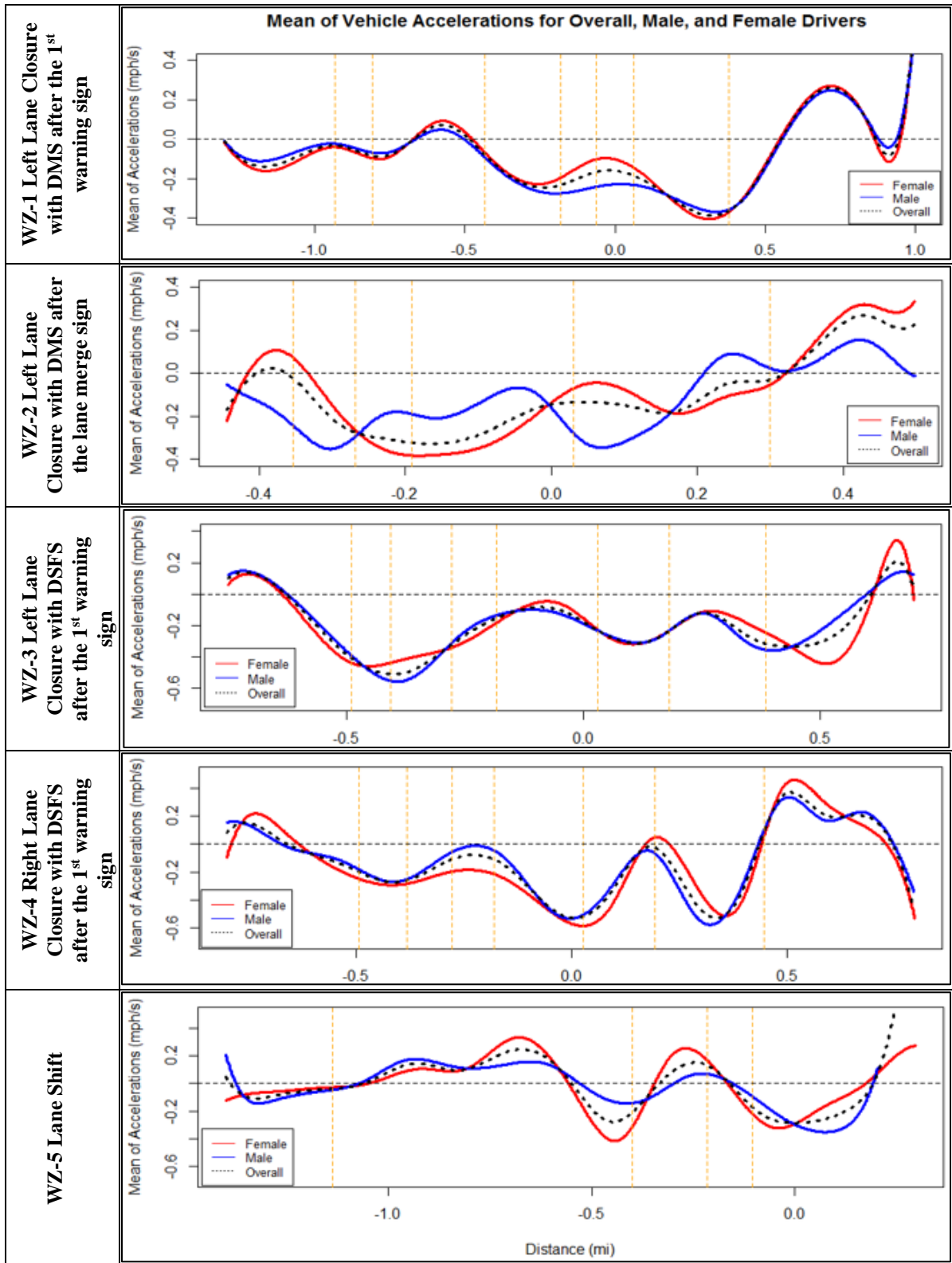

Figure 4.24 Mean of deceleration profiles for studied work zones and involved drivers by gender

The male drivers reacted to the merge sign and the DMS by decelerating at about 400 feet prior to the lane merge sign, however, female drivers had a period of acceleration before decelerating at about 100 feet prior to the lane merge sign. The maximum deceleration was reached at about 600 feet upstream of the taper point. The male drivers, on the other hand, had a shorter deceleration distance and started to accelerate from before the DMS to about 150 feet prior to the taper point, when they had a significant deceleration again.

The highest deceleration magnitude was observed in reaction to the first warning sign and the DSFS in work zone three, which was slightly sharper and lasted a shorter period for female drivers compared to the male drivers. The deceleration rate in reaction to the first warning sign and the DSFS in work zone four with a right lane closure was less significant than that in the work zone three with a left lane closure. There was a very significant deceleration in reaction to the taper area in work zone four and to a lesser degree in work zone one.

Periods of accelerations were observed due to inactivity in the work zone after the first warning sign, such as in work zone one and five. Drivers started to accelerate after a major deceleration to the highway guide sign in work zone five, where they started to decelerate again reacting to the shoulder taper. Also, drivers started to accelerate after periods of significant deceleration in reaction to the work area with the exception of work zone four when drivers encountered equipment and workers later in the work area.

Overall, there were sinusoidal waves on deceleration behavior in the majority of the work zones, however, it was more obvious in work zone four with a right lane closure.

#### 4.6.4 Effectiveness of Safety Features' Layout

There were various safety feature layouts in the 5 work zones in the study. The results revealed the first significant reaction to a work zone occurred in the closer proximity of the taper area. The presence of the DSFS in the safety features layout was very effective in reducing the mean speed by about 7 mph (12%) from 2,600 to 1,500 feet upstream of the taper location where the first three safety features applied. The reduction in mean speed in the right lane closure case was about 6% for similar distances. The presence of the DSFS in the layout resulted in a 4.4 and 3.6% increase in standard deviations for left and right lane closure scenarios, respectively.

Including the DMS in the first three safety features layout had a greater success in reducing the mean speed when it was utilized closer to the taper point. The mean speed was reduced by 3.5%, from 1,900 to 1,000 feet, however, it only decreased by 1.1% when measured from 5,000 to 2,300 feet upstream of the taper. The presence of the DMS at a closer proximity to the taper also was effective in reducing the speed variations by about 19% for overall and 48% for closed lane drivers at the similar interval.

The safety features layout in the lane shift scenario had a greater success in reducing the the speed variation. The combination of the lane shift sign and the lane shift were effective in reducing the mean speed by 3% from 1,650 feet prior to the lane shift location. The layout was effective in reducing the speed variability by about 17% from the upstream of the first warning sign to the lane shift area.

### 4.7 Conclusions

The advantage of employing FDA for speed time series traces in work zones was to exploit its tools to disclose information not otherwise achievable in the data. The analysis

using FDA revealed interactions of drivers with various safety features in work zones not easily seen with conventional statistical approaches. The study illustrated key aspects of FDA using real data from SHRP 2 NDS with several key features. The NDS data were drawn from a continuous measurement with a smooth underlying process at a high frequency and replicated curves.

The features of FDA were useful in summarizing the average driver's behavior from a group of repeated speed time series traces in work zones to identify the effectiveness of countermeasures utilized to get driver's attention to slow down and safely traverse the work zone. The standard deviation and confidence interval of data provided important information about speed variability, a major contributing factor to work zone safety critical events, associated with each countermeasure and a set of countermeasures collectively. The informative exploratory feature of functional boxplots provided a solid range of data for analyzing driver behavior in reaction to various safety measures in work zones. The first derivative of speed profiles provided additional information about the nature of drivers and countermeasures interactions.

The study results revealed many promising findings about the drivers' interactions with work zones, the effectiveness of safety features utilized, and the location and layout of the safety features that enhance their effectiveness.

The study findings suggest the DMS is effective in getting driver's attention to reduce speed upstream of the taper area if applied at a closer proximity to the taper location. The DMS at this location also was effective in reducing speed variability in the overall model.

A long distance between the first and second warning signs with no indications of construction activities caused drivers to ignore the warning sign and accelerate again inside the work zone.

The combination of safety features such as a flashing arrow and channelization caused a significant decrease in the speed and speed variations, simultaneously.

The presence of equipment and workers in the work area was very effective in getting drivers' attention to reduce their speed, however, it caused mixed results on speed variability.

The DSFS was the single most effective safety features to get drivers to reduce their speed for overall, male, female, open lane, and closed lane drivers in the analysis models.

The first derivative of speed profiles also provided invaluable information about the drivers' deceleration behavior toward various safety features. The findings had important implications for improving work zone safety features layout and identifying the most effective safety features. The deceleration profiles showed an early and a significant decrease in reaction to the first warning sign and the DSFS at the upstream of the taper location. Also, the application of the lane merge sign and the DMS more proximate to the taper area caused a significant decrease in deceleration rates.

The combined effect of the work zone warning signs and a merge sign with an attached advisory speed plate were significantly effective to get driver's attention to reduce their speed in an early reaction to the presence of a work zone with a lane closure. However, the safety features layout of a lane shift scenario was very effective in reducing speed variability, which was identified to be an important contributing factor in work zone safety.



#### 4.8 References

1. National Work Zone Safety Information Clearinghouse. Traffic Crashes in Work Zones. <https://www.workzonesafety.org/crash-information/workzone-fatalities/workzone-fatalitiesmotor-vehicle-traffic-crashes-2014/>. Accessed November 2016.
2. Rumar K., Evans L. & Schwing R. The Role of Perceptual and Cognitive Filters in Observed Behavior. Human Behavior in Traffic Safety, eds. Plenum Press, 1985.
3. National Highway Traffic Safety Administration, Traffic Safety Facts, Crash Statistics, February 2015. <https://crashstats.nhtsa.dot.gov/Api/Public/ViewPublication/812115>. Accessed 8/28/2017.
4. Salmon, P. M., Regan, M. A., Johnston, I. Human error and road transport: Phase one- a framework for an error tolerant road transport system. Monash University Accident Research Centre, (2005).
5. Dingus, T. A., Hankey, J. M., Antin, J. F., Lee, S. E., Eichelberger, L., Stulce, K., McGraw, D., Perez, M., Stowe, L. (May, 2014). *Naturalistic Driving Study: Technical Coordination and Quality Control*. Virginia Tech Transportation Institute. Blacksburg, VA.
6. Smadi, O. SHRP 2 S-04A Roadway Information Database Development and Technical Coordination and Quality Assurance of the Mobile Data Collection Project. Presented at the 7th SHRP 2 Safety Research Symposium, Washington D.C., 2012.
7. Levitin et al. Introduction to Functional Data Analysis. Canadian Psychology 2007, Vol. 48, No. 3, 135-155.
8. Ramsay, J. and Silverman, B. W. (2002). Applied functional data analysis. Springer-Verlag New York.
9. Ramsay, J. and Silverman, B. W. (2005). Functional data analysis. Springer-Verlag New York.
10. Cindie Andrieu, Guillaume Saint Pierre, Xavier Bressaud. A functional analysis of speed profiles: Smoothing using derivative information, registration, and speed corridors. 2013.

11. Bi, J. and Kuesten, C. Using Functional Data Analysis (FDA) Methodology and the R Package “fda” for Sensory Time-Intensity Evaluation. *Journal of Sensory Studies*, Vol. 28, 2013, 474-482.
12. Traffic Safety Facts 2008. National Highway Traffic Safety Administration. Report No. DOT HS 810 631, U.S. Department of Transportation, Washington, D.C., 2009.
13. Federal Highway Administration. Facts and Statistics – Work Zone Safety. Retrieved on August 28, 2017, [https://ops.fhwa.dot.gov/wz/resources/facts\\_stats/safety.htm](https://ops.fhwa.dot.gov/wz/resources/facts_stats/safety.htm)
14. Li, Y., Bai, Y. Highway Work Zone Risk Factors and Their Impact on Crash Severity. *Journal of Transportation Engineering*, 135(10), pp. 694–701, 2009.
15. Dissanayake, S., Akepati, S. R. Identification of Work Zone Crash Characteristics. Final Report. Department of Civil Engineering, Kansas State University, 2009.
16. Outcalt, W. S. Work Zone Speed Control. Colorado Department of Transportation, DTD Applied Research and Innovation Branch, 2009.
17. Fitzsimmons, E., Oneyar, N., Hallmark, S., Hawkins, N., and Maze, T. Synthesis of Traffic Calming Techniques in Work Zones, Final Report, January 2009.
18. Garber, N. J., and Patel, S. T. Control of Vehicle Speeds in Temporary Traffic Control Zones (Work Zones) Using Changeable Message Signs with Radar. In *Transportation Research Record 1509*. TRB, National Research Council, Washington, D.C., 1995.
19. Shaik, N. M., Sanford Bernhardt, K. L., and Virkler, M. R. Evaluation of Three Supplementary Traffic Control Measures for Freeway Work Zones. *Mid-Continent Transportation Symposium Proceedings*, Iowa State University, Ames, Iowa, May 2000.
20. Maze, T., Kamyab, A., and Schrock, S. Evaluation of work zone speed reduction measures, CTRE Management Project 99-44, Iowa Department of Transportation, April 2000.
21. Sommers, N. M., and McAvoy, D. S. Improving Work Zone Safety through Speed Management. Ohio State University, June 2013.
22. Garber, N. J. and Patel, S. T. Effectiveness of Changeable Message Signs in Controlling Vehicles Speeds in Work Zones Report No. VTRC 95-R4. Virginia Transportation Research Council, Charlottesville, Virginia, 1994.

23. Brewer, M. A., Pesti, G., and Schneider, W. IV (2006). "Improving Compliance with Work Zone Speed Limits: Effectiveness of Selected Devices." Transportation Research Record 1948. Transportation Research Board, Washington, D.C., pp. 67–76.
24. Zech, W. C. and Mohan, S. B. Evaluation of Messages on Changeable Message Signs as a Speed Control Measure in Highway Work Zones. Practical periodical on Structural Design and Construction 13(1), ASCE, pp.11-18, 2008.
25. Li, Y., & Bai, Y. Determining the optimal deployment location of portable changeable message signs in the upstream of work zones, 2011.
26. McCoy, P.T., Bonneson, J. A., and Kollbaum, J. A. Speed Reduction Effects of Speed Monitoring Displays with Radar in Work Zones on Interstate Highways. Transportation Research Record, No. 1509, pp. 65-72. Transportation Research Board, Washington D.C., 1995.
27. Pesti, G. and McCoy, P. T. Long Term Effectiveness of Speed Monitoring Displays in Work Zones on Rural Interstate Highways", Paper No. 01-2789, Transportation Research Board, Washington D.C., 2001.
28. Hallmark, S. and Hawkins, N. Dynamic Speed Feedback Sign. Institute for Transportation, Iowa State University, October 2014.
29. Carlson, P.J., et al., Evaluation of Traffic Control Devices for Rural High-Speed Maintenance Work Zones, Texas A&M University–Texas Transportation Institute, College Station, 2000
30. McCoy, P.T. and G. Pesti, G. Effectiveness of Condition-Responsive Advisory Speed Messages in Rural Freeway Work Zones. Transportation Research Record, No. 1794, pp. 11–18, Transportation Research Board Washington, D.C., 2002.
31. Hajbabaie, A., Medina, J., Wang, M. H., Benekohal, R., and Chitturi, M. Sustained and Halo Effects of Various Speed Reduction Treatments in Highway Work Zones. Transportation Research Record, No. 2265, pp. 118–128 Transportation Research Board, Washington, D.C., 2011.
32. Pesti, G. and P.T. McCoy. Effect of Speed Monitoring Displays on Entry Ramp Speeds at Rural Freeway Interchanges. TRB 2002 Annual Meeting CD-ROM, Paper No. 02-2571, TRB, National Research Council, Washington, D.C., 2002.
33. Benekohal, R., Wang, M., Chitturi, M., Hajbabaie, A., and Medina, J. Speed Photo-Radar Enforcement and Its Effects on Speeds in Work Zones, 2008.

34. Hildebrand, E. D. and Mason D. D. Effectiveness of countermeasures to reduce vehicle speeds in freeway work zones. *Canadian Journal of Civil Engineering*, Vol. 41, 2014
35. Federal Highway Administration (FHWA), *Manual on Uniform Traffic Control Devices for Streets and Highways*, 2009.  
<https://mutcd.fhwa.dot.gov/htm/2009/part6/part6h.htm>
36. Sun, Y. and Genton, M.G. Functional Boxplots. *Journal of Computational and Graphical Statistics*, Volume 20, Issue 2, pp. 316-334, 2011
37. Bertucci, A. *Sign Legibility Rules of Thumb*, United States Sign Council, 2006
38. Federal Highway Administration (FHWA), *Manual on Uniform Traffic Control Devices for Streets and Highways*, 2009. Changeable Message Signs, Chapter 2L, Legibility and Visibility of Changeable Message Signs, Section 2L.03  
<https://mutcd.fhwa.dot.gov/htm/2009/part2/part2l.htm>
39. Paniati, J. F. (1988, October). Legibility and comprehension of traffic sign symbols. In *Proceedings of the Human Factors Society Annual Meeting* (Vol. 32, No. 10, pp. 568-572). Sage CA: Los Angeles, CA: SAGE Publications.
40. Zwahlen, Helmut T., Xiaohong Hu, Murali Sunkara, and LuAnn M. Duffus. "Recognition of traffic sign symbols in the field during daytime and nighttime." In *Proceedings of the Human Factors Society Annual Meeting*, vol. 35, no. 15, pp. 1058-1062. Sage CA: Los Angeles, CA: SAGE Publications, 1991.

## CHAPTER 5. GENERAL CONCLUSIONS

### 5.1 Conclusions and Implications

There are a large and increasing number of road segments under construction as the highway system ages and requiring continuous maintenance and capacity development. The presence of a work zone increases the disturbance to traffic flow and can create severe safety issues. With a large number of fatalities and injuries occurring in work zones, improvements in work zone safety is a major concerns for transportation agencies the travelling publics, and construction workers.

There are a large number of factors contributing to work zone crashes but it is believed that the major contributing factors are excessive speeding, speed variability, and inattentive driving. A number of countermeasures have been proposed and utilized to get drivers' attention and encourage safe driving in work zones, but there is limited information about the effectiveness of those countermeasures since driver behaviors are not clearly understood. The traditional method is to use the crash data to determine and evaluate crash causation, but crash data only include limited detail about the situation and does not address human contributing factors effectively. As the past research identified driver as the major contributing factor in crashes, there is little information in crash reports describing how the driver contributed to the work zone crash.

The NDS data, developed by the SHRP 2, provided a unique opportunity to observe actual driver behavior from a wide variety of drivers with broad age ranges in multiple states in order to understand how they interact with the presence of work zones and a set of safety features intended to encourage safe travel through work zones.

Analyzing crash data is not a new idea, but the NDS provided researchers with important additional data about the driver, roadway, and traffic environment through collection of time series and video data to help understand the role of the driver, as the major contributing factor to vehicle crashes, in traffic safety.

The general objective of this dissertation was to utilize SHRP 2 NDS and RID data to develop models which can provide a thorough understanding of drivers' work zone negotiations and interactions when various safety features are deployed. This was accomplished by developing a number of models to identify the major contributing factors to safety critical events, investigating how drivers interact with work zones with different characteristics and various safety feature layouts, and examining the effectiveness of individual safety features utilized to reduce vehicle speed in various work zones through three papers.

The objective of the first paper in chapter 2 was to investigate the characteristics of safety critical events and compare that to the baseline events to identify the main contributing factors associated with work zone safety critical events. A total of 110 safety critical events and 89 baseline events were included in the analysis. The descriptive statistics revealed a number of important findings in this research. The rear end crashes attributed to more than 67% of safety critical events. Young drivers (16-24) as well as female drivers were over-represented in safety critical events. The descriptive statistics also revealed 56% of drivers were engaged in secondary tasks before the occurrence of safety critical events. Distractions and speeding accounted for 60% of driver behaviors that contributed to these events.

The logistic regression model was used to predict the outcome of an event based on various identified explanatory variables. The model found 6 out of 18 tested variables to be

statistically significant. All variables remained in the model were significant at a 90% confidence level. Excessive speed, speed variations, distractions, interchange/intersection, urban area, and gender were significant and all positively correlated with the occurrence of safety critical events in work zones. The odd ratios provide insight about the magnitude of the predictors and found speeding, with a value of 11.7, to be the highest contributing factor to the event outcome. Higher speed variation also was an important contributing factor to increase the probability of safety critical events involvement. The probability of being involved in a safety critical event was 2.53 times greater than that for a baseline event when speed variation was high at work zones.

The findings of this research could be used by transportation agencies to make informed decisions in developing appropriate safety strategies and deploying effective countermeasures to get drivers' attention and reduce traffic speeds in response to the presence of a work zone.

The second paper in Chapter 3 observed and analyzed driver behavior by using the speed time series data and forward videos in work zones. This study was successful in identifying the effectiveness of safety measures in various work zones with different characteristics. The PELT algorithm in multiple changepoint analysis effectively developed models to detect drivers' interactions with a series of safety features in a variety of work zones with different traffic control plans. The study revealed a significant speed variability for work zones with lane closure scenarios, particularly for those with speed reduction requirements. There was a high variation in mean speed for the work zones with a low speed limit of 45 mph. Male drivers' median speed was higher than that for female drivers,

however, female drivers showed higher speed variations. A higher variability was also observed in open lane when compared to closed lane traces.

Female drivers generally had an earlier and slightly more significant reactions to the safety measures applied from the first warning sign up to the taper location compared to male drivers. Closed lane drivers were less reactive to the safety countermeasures applied prior to the taper area. The effect of a DMS is more pronounced when applied closer to the taper area.

The findings of this research suggest applying more efficient safety features, such as a DMS in closer proximity to the taper area, are very effective encouraging drivers to slow down in work zones. A long distance between the first and second work zone warning signs with no activity has a contrary effect on speed reduction and eliminates the effect of the first warning sign. No speed reduction in work zones with a lane closure and 70 mph speed limit proved to be constructive in reducing speed variability. On the contrary, low work zone speed limits increased speed variability substantially.

The combined DSFS and the first warning sign were found to be the most effective safety features to encourage speed reduction in work zones. The combination of the first warning sign and the DSFS along with the flashing arrow, tapering, and channelization had the highest combined effect in reducing mean speed in the work zone by as much as 40%. The combination of work zone warning signs with the attached advisory speed plate and the DSFS at 2,640 and 2,100 feet upstream of the taper location was a very successful safety strategy to slow the traffic before reaching to the taper area.

The PELT algorithm in the multiple changepoint analysis was utilized to identify the optimal number and locations of multiple changepoints in the work zone speed time series



traces. The location and magnitude of changepoints provided valuable information about the effectiveness of a safety feature or the combined effects of various features to partition speed time series data into multiple segments with various statistical properties. The analysis revealed critically important discoveries about drivers' interactions with the safety features utilized in the work zone and the dominant safety features in various work zones with different characteristics.

The final paper in chapter 4 utilized the features of FDA to summarize driver behavior by analyzing speed time series data from SHRP 2 NDS. This study focused on five work zones, 4 with lane closures and one with a lane shift scenarios. The main purpose of this study to satisfy the limitations of the study in chapter 3 to investigate the effectiveness of any individual safety feature by examining the change in mean speed from a legible distance to that feature. Additionally, it was intended to discover where drivers start to react to the presence of a work zone and which safety features layout was the most successful to get driver's attention to slow down prior to the merging point.

The FDA involved several processes including the smoothing to convert the raw discrete time series data to functional data. The smoothing process of the FDA analysis was utilized to remove large noises from the raw data which helps to identify the unbiased average driver behavior for a series of repeated speed time series profiles. The average speed and the confidence interval were plotted to illustrate drivers' speed behavior and interactions with work zones and utilized safety measures.

The change in mean speed from a legible distance upstream of the safety feature was calculated and one sample t-test was utilized to learn if the countermeasure was effective to significantly change the mean speed. The DSFS was the most effective safety feature to

encourage safe driving in work zones. The DMS was effective in reducing speed as well as speed variability when applied at a closer proximity to the taper location. The mean speed plots indicate the presence of a DSFS caused the first significant reaction to the work zone and was similar for a DMS when it was utilized in a closer proximity to the taper point.

The results also indicated the inclusion of a DSFS in the safety features layout was very effective in reducing the mean speed by about 7 mph (12%) from 2,600 to 1,500 feet upstream of the merging point. The study findings revealed the utilization of the DMS in the first three safety features layout in close proximity to the merging location reduced the mean speed by 3.5% from 1,900 to 1,000 feet upstream of the taper. The plots of functional mean and the confidence interval was very useful to demonstrate when drivers had their first significant reaction to the work zone and how they changed their speed in reaction to the utilized countermeasures.

The recently developed technique of a functional boxplot was used to examine the depth of the middle 50% and the centrality variations of functional data. The informative exploratory feature of a functional boxplot was utilized to observe and examine the effect of the work zone and safety features on speed variability, a major contributing factor to work zone safety critical events. The investigation of functional boxplots revealed the central 50% depth was wider for female and open lane drivers, which indicated a higher variability in the solid range of the data. It also showed male drivers' tendency is toward the higher range while female drivers tend to drive at the lower range of the 50% depth. The lane shift scenario showed a narrower middle 50% depth and lower extremes, however, introduced more outliers.

The first derivative of speed profiles provided additional invaluable information about the drivers' deceleration behavior toward various safety features. The findings had important implications for improving work zone safety features layout and identifying the most effective safety features. The deceleration profiles revealed that deceleration rates reached the maximum in the work zone after drivers reacted to a DSFS. The exception was when the DSFS was applied at the work zone with a right lane closure where the maximum deceleration was reached at the taper and the work area. This may be due to the large number of traces in the inside (closed) lane where drivers usually drive at a lower speed. The inside lane drivers have less difficulty in finding a gap to merge into the outside (open) lane. It also showed that a maximum deceleration in the work zone was reached after drivers reacted to the DMS when utilized in a close proximity to the merge point. In the work zone with a left lane closure and no ITS applications, the maximum deceleration was reached in response to the work area and the presence of equipment and workers.

The advanced techniques of FDA were found to be a cutting-edge approach to analyze driver behavior in the state of the art SHRP 2 NDS work zone data. The FDA methods were utilized to visualize the normal driver behavior and determine any change in behavior in reaction to various safety features in work zones. The exploratory functional boxplots provided important understandings of driver behavior when concentrating on the less biased and solid range of data, the middle 50% depth to examine the centrality, and its variations. The derivative of speed profiles also provided vital information about the drivers' deceleration behavior toward various safety features. The findings had important implications for improving work zone safety features layout and identifying the most effective safety features in safety feature layouts.

All in all, the findings of the studies in this dissertation, and particularly the two leading-edge analyses of multiple changepoints and the FDA methods, discovered drivers' speed behavior in a variety of work zones over the state-of-the-art SHRP 2 NDS dataset in a scale and detail that had never been studied. The NDS data provided a unique opportunity to identify the contributing factors to safety critical events in work zones and the utilization of the changepoints modeling and the FDA analysis provided valuable information about driver behavior, the most significant and most unknown contributing factor to all crashes. The findings have multiple important implications for transportation agencies, including updating their current TTCD with inclusion of the more effective safety features and possible optimal locations for utilization of those features, creating a more appropriate driver training program, and deploying the most effective safety features layout.

## 5.2 Limitations

The main limitation of this dissertation was in the first study which had a small sample size for safety critical events and baseline events. The small sample size of 110 crashes and near crashes was mainly due to the scarcity of those events in work zones in SHRP 2 NDS data. This created some hurdles in building statistical inferences from the logistic regression model. Some of the variables in work zone related-data were combined for the purpose of analysis due to the small sample size and the diversity of categories in each variable. The small sample size is the main issue in analyzing some of the predominant factors in our data set. For example, all type of cell phone-related distractions were combined, therefore, the effect of texting and cell phone usage on the outcome of an event could not be verified due to the small sample size. Due to the scarce number of the safety critical events in the NDS data, it is recommended to use crash surrogates to model the safety

impacts associated with work zones. The baseline data is limited to 89 observations including multi-lane highways only, due to time and budget constraints. This may not be representative of all the SHARP 2 NDS baseline data and may affect our results.

Also in the first study the baseline events were coded by VTTI for only 21 seconds durations. The segment of work zones coded could occur in any area of the work zone (upstream, work area, or downstream). Therefore, none of the baseline events include the full driving trace from upstream all the way throughout the work area.

The study constraint of the second paper in chapter 3 was the low number of work zones with similar configurations and TTC layout. Even work zones with identical safety features layout had different locations for the placement of safety features in regard to the taper location. Since this was a naturalistic driving in a natural environment, we had no control over the work zone configurations and safety measures layout unlike the experimental setups. The larger sample size is always preferred to minimize the effects of outliers. Having a higher number of traces for all work zone configurations and all sub-groups of data would help to give more statistical power to our study results.

### 5.3 Future Research

The merging maneuver creates conflicts with traffic in both closed and open lanes, which increases crash risks. Therefore, merging behavior is a major safety concerns in work zones. A study may be conducted to investigate how drivers negotiate work zones and analyze factors influencing drivers' merging behavior in work zones. This can be done by utilizing lane positioning variables in SHRP 2 NDS to verify the exact merging point for each trace in the work zone. Next the merging location of many traces can be identified and plotted in the work zone. Then the merging locations can be categorized as early,

intermediate, and late merge. There are many variables that can influence driver merging behavior, including distractions, excessive speeding, speed variations, posted speed limits, number of closed lane, a DMS, and a DSFS. Additionally, driver data such as age, gender, and prior traffic violations can be included in the study. The variables and the significance they contribute to each category can then be tested.

The merging study can be expanded to investigate driver merging behavior associated with different work zone configurations and find the associated safety risks. For example, the merging behavior of work zones with left lane closures can be compared with those with right lane closures. As our study indicated, the outside lane drivers are usually driving at higher speeds and tend to attempt a late merge which is challenging to find a gap in the open lane, which raise important safety concerns. However, the majority of drivers were driving on the inside lane and tended to drive at a lower speed than the outside lane drivers. It seems they might have less difficulty in finding a gap to merge in to the open lane in the right lane closure scenario. There are situations where transportation agencies may have the option of left or right lane closure in order to direct traffic to the opposite side of the roadway. The findings of this study can help them to make an informed decision about lane closure deployment.

Another important study could be the analysis of driver behavior and the effectiveness of safety features utilized in work zones in daytime versus the night time. The data reduced in this dissertation had very low proportion of night time traces, therefore it was not possible to investigate the effectiveness of countermeasures at night time.

Finally, the baseline traces for before the implementation of work zone and the TTCD can be obtained and compared to when the work zone and safety features were deployed. The

work zone speed profiles and speed variability data in work zones can be compared to the baseline traces to determine whether the mean speed and the standard deviation of the speed had changed at a statistically significant level.

## APPENDIX A. IRB APPROVAL FORM

**IOWA STATE UNIVERSITY**  
OF SCIENCE AND TECHNOLOGY

Institutional Review Board  
Office for Responsible Research  
Vice President for Research  
1138 Pearson Hall  
Ames, Iowa 50011-2207  
515 294-4566  
FAX 515 294-4267

**Date:** 4/18/2016

**To:** Dr. Shauna Hallmark  
2711 S Loop Dr, Suite 4700

**From:** Office for Responsible Research

**Title:** Evaluation of Work Zone Safety Using the SHRP 2 Naturalistic Driving Study Data -- Phase II

**IRB ID:** 16-160

**Study Review Date:** 4/18/2016

The project referenced above has been declared exempt from the requirements of the human subject protections regulations as described in 45 CFR 46.101(b) because it meets the following federal requirements for exemption:

- (4) Research involving the collection or study of existing data, documents, records, pathological specimens, or diagnostic specimens if these sources are publicly available or if the information is recorded by the investigator in such a manner that subjects cannot be identified directly or through identifiers linked to the subjects.

The determination of exemption means that:

- **You do not need to submit an application for annual continuing review.**
- **You must carry out the research as described in the IRB application.** Review by IRB staff is required prior to implementing modifications that may change the exempt status of the research. In general, review is required for any modifications to the research procedures (e.g., method of data collection, nature or scope of information to be collected, changes in confidentiality measures, etc.), modifications that result in the inclusion of participants from vulnerable populations, and/or any change that may increase the risk or discomfort to participants. Changes to key personnel must also be approved. The purpose of review is to determine if the project still meets the federal criteria for exemption.

Non-exempt research is subject to many regulatory requirements that must be addressed prior to implementation of the study. Conducting non-exempt research without IRB review and approval may constitute non-compliance with federal regulations and/or academic misconduct according to ISU policy.

**Detailed information about requirements for submission of modifications can be found on the Exempt Study Modification Form.** A Personnel Change Form may be submitted when the only modification involves changes in study staff. If it is determined that exemption is no longer warranted, then an Application for Approval of Research Involving Humans Form will need to be submitted and approved before proceeding with data collection.

Please note that you must submit all research involving human participants for review. **Only the IRB or designees may make the determination of exemption**, even if you conduct a study in the future that is exactly like this study.

Please be aware that **approval from other entities may also be needed.** For example, access to data from private records (e.g. student, medical, or employment records, etc.) that are protected by FERPA, HIPAA, or other confidentiality policies requires permission from the holders of those records. Similarly, for research conducted in institutions other than ISU (e.g., schools, other colleges or universities, medical facilities, companies, etc.), investigators must obtain permission from the institution(s) as required by their policies. **An IRB determination of exemption in no way implies or guarantees that permission from these other entities will be granted.**

Please don't hesitate to contact us if you have questions or concerns at 515-294-4566 or IRB@iastate.edu.